



Circuit Breaker  
Accessory

For Frames -  
DK, KDB  
KD, HKD, KDC  
KW, HKW, KWC

Eaton Corporation  
Electrical Sector  
1111 Superior Ave.  
Cleveland, OH  
44114  
United States

4217B82H05

Effective  
February 2012

### Terminal Adapter Assembly

Cat. Number - TAD3  
Style No. - 5092A64G31  
Quantity - 3

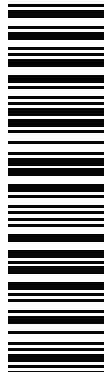
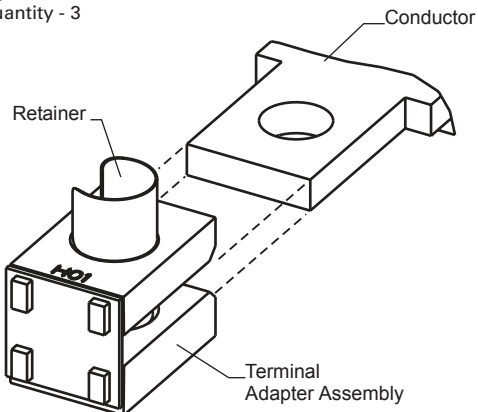

1 07 86679 16148 4

#### Instructions For Assembly:

Push Adapter Assembly Over End Of Conductor.  
Holes In Assembly Must line Up With Clearance Hole  
In Conductor.  
Push Retainer Into Conductor Hole To Keep Adapter  
On Conductor.



Circuit Breaker  
Accessory

For Frames -  
DK, KDB  
KD, HKD, KDC  
KW, HKW, KWC

Eaton Corporation  
Electrical Sector  
1111 Superior Ave.  
Cleveland, OH  
44114  
United States

4217B82H05

Effective  
February 2012

### Terminal Adapter Assembly

Cat. Number - TAD3  
Style No. - 5092A64G31  
Quantity - 3

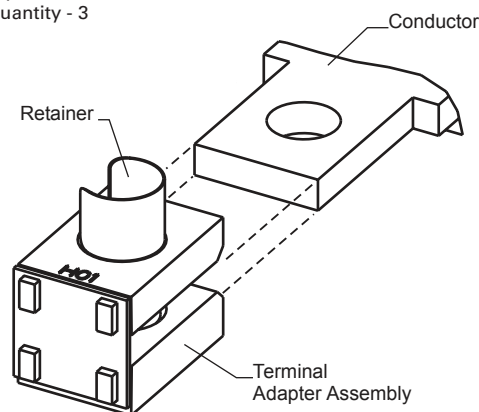

1 07 86679 16148 4

#### Instructions For Assembly:

Push Adapter Assembly Over End Of Conductor.  
Holes In Assembly Must line Up With Clearance Hole  
In Conductor.  
Push Retainer Into Conductor Hole To Keep Adapter  
On Conductor.



Circuit Breaker  
Accessory

For Frames -  
DK, KDB  
KD, HKD, KDC  
KW, HKW, KWC

Eaton Corporation  
Electrical Sector  
1111 Superior Ave.  
Cleveland, OH  
44114  
United States

4217B82H05

Effective  
February 2012

### Terminal Adapter Assembly

Cat. Number - TAD3  
Style No. - 5092A64G31  
Quantity - 3

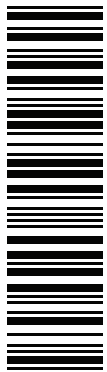
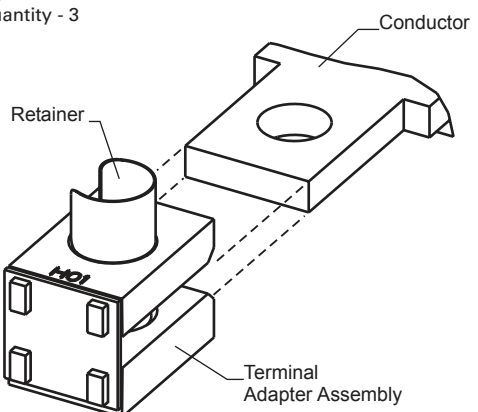

1 07 86679 16148 4

#### Instructions For Assembly:

Push Adapter Assembly Over End Of Conductor.  
Holes In Assembly Must line Up With Clearance Hole  
In Conductor.  
Push Retainer Into Conductor Hole To Keep Adapter  
On Conductor.



Circuit Breaker  
Accessory

For Frames -  
DK, KDB  
KD, HKD, KDC  
KW, HKW, KWC

Eaton Corporation  
Electrical Sector  
1111 Superior Ave.  
Cleveland, OH  
44114  
United States

4217B82H05

Effective  
February 2012

### Terminal Adapter Assembly

Cat. Number - TAD3  
Style No. - 5092A64G31  
Quantity - 3

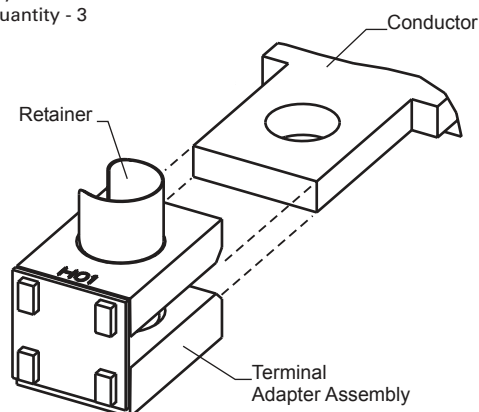

1 07 86679 16148 4

#### Instructions For Assembly:

Push Adapter Assembly Over End Of Conductor.  
Holes In Assembly Must line Up With Clearance Hole  
In Conductor.  
Push Retainer Into Conductor Hole To Keep Adapter  
On Conductor.