

Instruction Leaflet for the KES 310+ Electronic Trip Unit

Contents

Description	Page
1. Trip Unit Installation	2
2. Trip Unit Controls and Functions	4
3. Neutral Current Sensor Installation	6
4. 100% Rated K-Frame Breakers	7

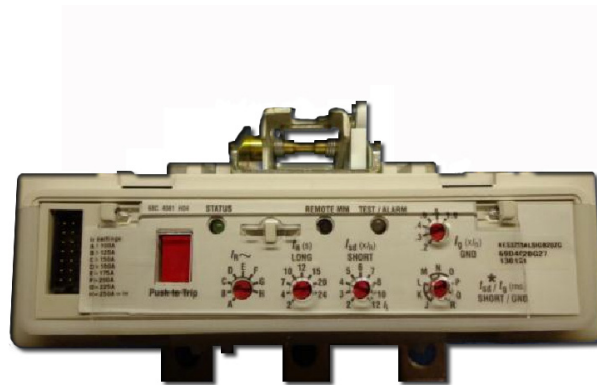

⚠ WARNING

DO NOT ATTEMPT TO INSTALL OR PERFORM MAINTENANCE ON EQUIPMENT WHILE IT IS ENERGIZED. DEATH OR SEVERE PERSONAL INJURY CAN RESULT FROM CONTACT WITH ENERGIZED EQUIPMENT. ALWAYS VERIFY THAT NO VOLTAGE IS PRESENT BEFORE PROCEEDING.

1. Trip Unit Installation

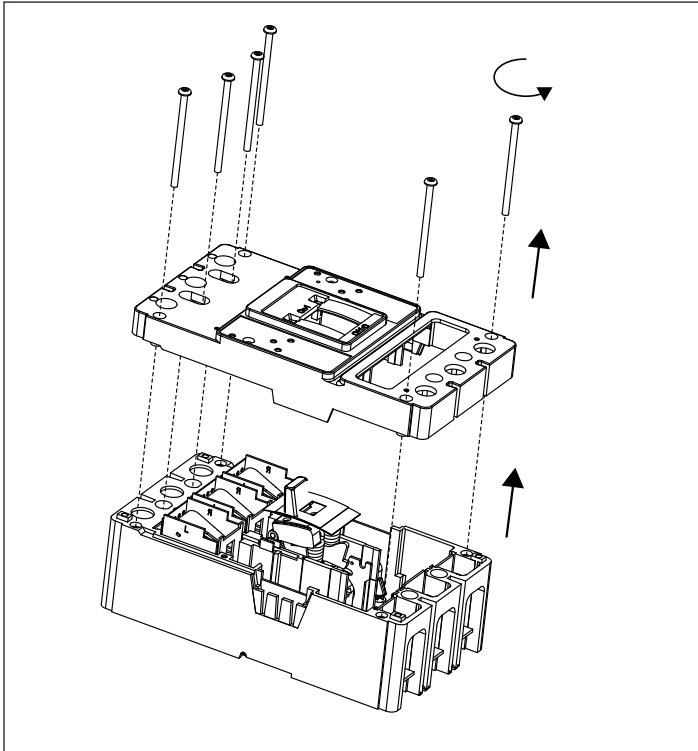

Figure 1.

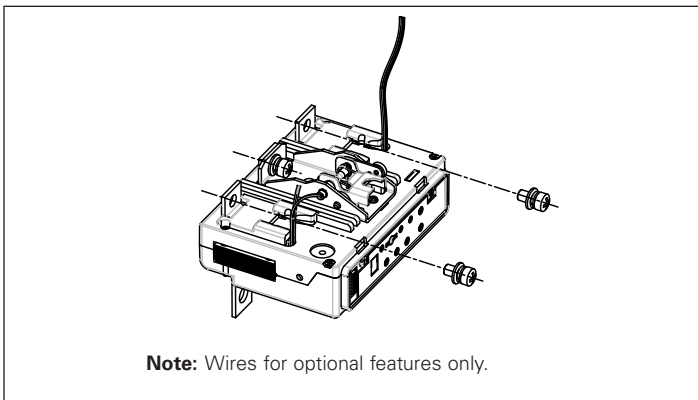

Figure 2.

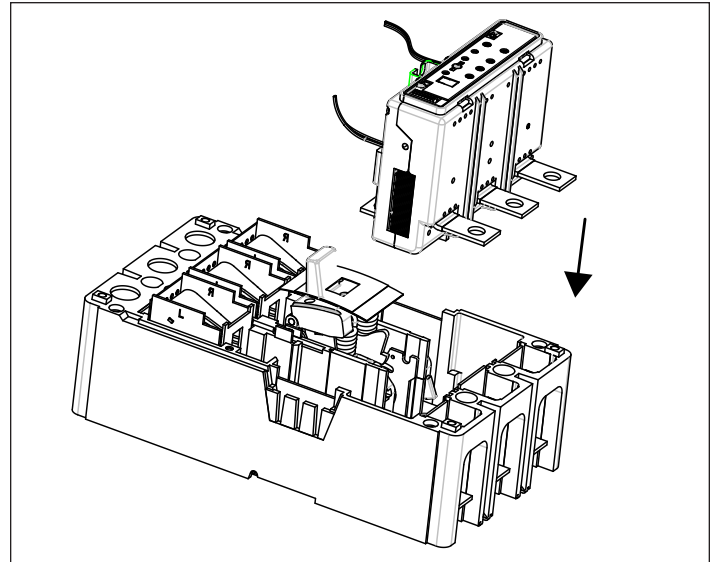

Figure 3.

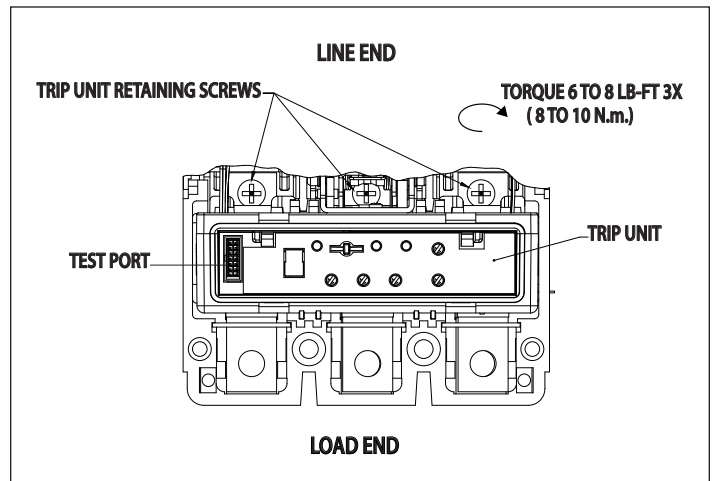

Figure 4.

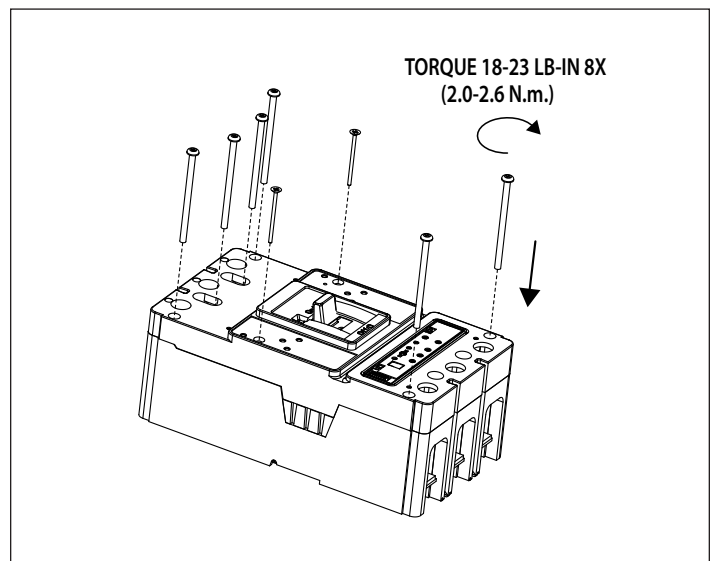

Figure 5.

4 Pole Trip Unit Installation

Remove the 3 retaining screws from the shunt plate inserts in the base of the circuit breaker frame.

Remove the conductor bar from the right-hand (fourth) pole and discard the conductor but keep the retaining screw.

Remove the barrier between the third and fourth (right-hand) pole. Find the scored tab and break away from the barrier to leave a square notch. (See Figure 6).

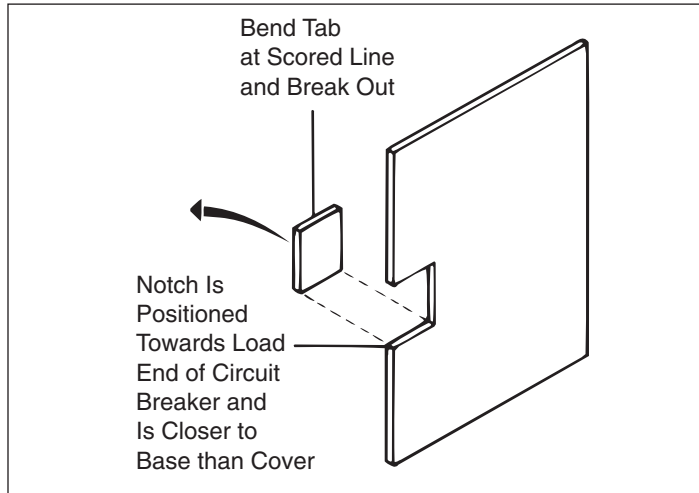

Figure 6. Scored Tab in Barrier.

Remove the CAUTION tag from the current sensor secondary winding leads.

Plug the current sensor secondary winding connector into the receptacle in the side of the trip unit. Either polarity is acceptable since the secondary winding connector is not polarized.

Position the retaining screws in the trip unit and current sensor conductor holes.

Place the barrier with the notch between the trip unit and the current sensor. (See Figure 7). The notch must fit around the secondary winding connector.

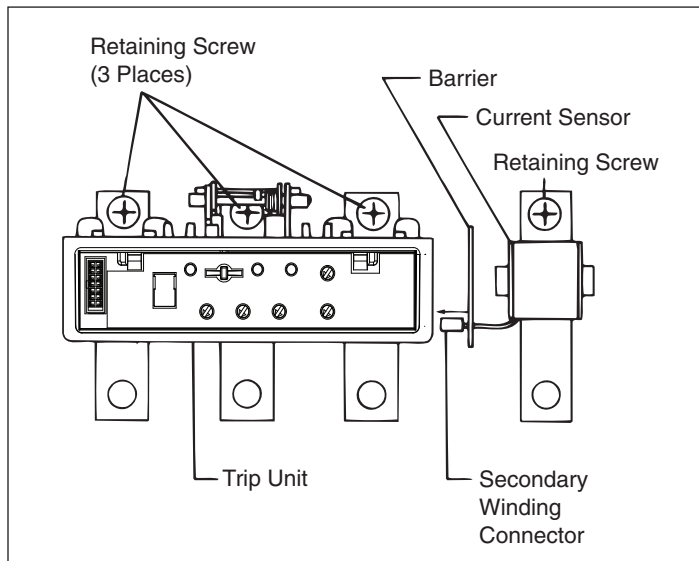

Figure 7. Alignment of Trip Unit and Current Sensor.

Position the trip unit together with the barrier and current sensor in the circuit breaker. Make sure the latch bracket pin is properly seated in the slots in the side plates. (See Figure 8). If necessary, the latch may be moved toward the load end of the circuit breaker to seat the trip unit.

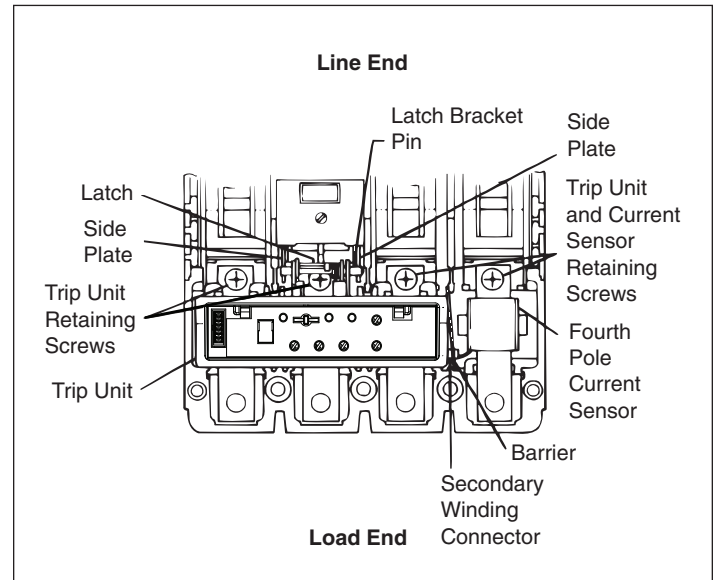

Figure 8. Trip Unit Installed in Circuit Breaker.

Tighten the three retaining screws in the trip unit and the fourth retaining screw in the current sensor. Torque to 6 – 8 lb.-ft. (8 – 10 N.m.)

CAUTION

DO NOT EXCEED A TORQUE OF 6 – 8 LB.-FT. (8 – 10 N.M.). EXCESSIVE TORQUING WILL SHEAR THE SCREWS. FAILURE TO APPLY THE REQUIRED TORQUE MAY LEAD TO EXCESSIVE HEATING AND CAUSE NUISANCE TRIPPING OF THE CIRCUIT BREAKER.

Install any accessories, if required, using the appropriate instruction leaflet.

Finish the installation of the 4-pole trip unit by following Figure 5.

2. Trip Unit Controls and Functions

8a

* Settings		I_g (ms)		
I_{sd} (ms)	Inst.	J	K	L
300	120	M	N	O
	300	P	Q	R

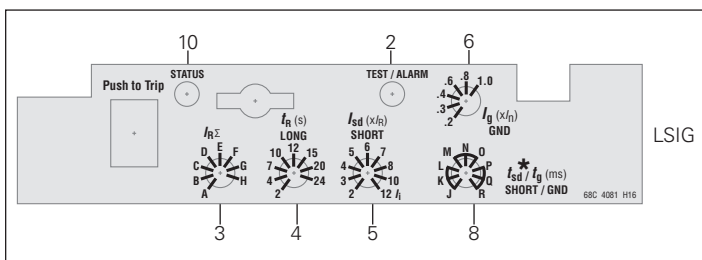
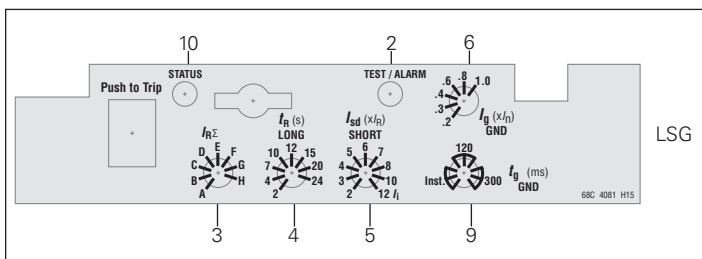
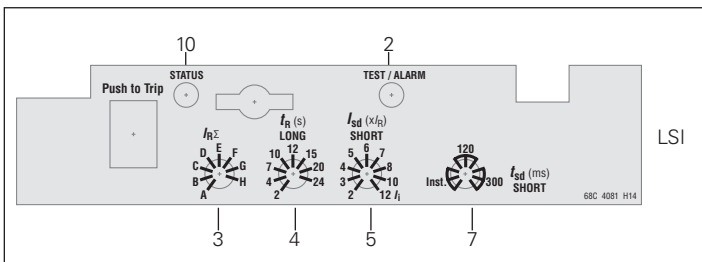
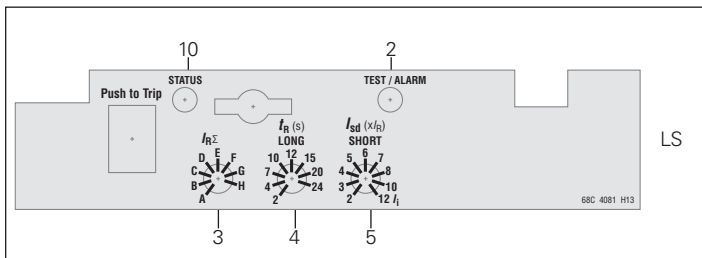
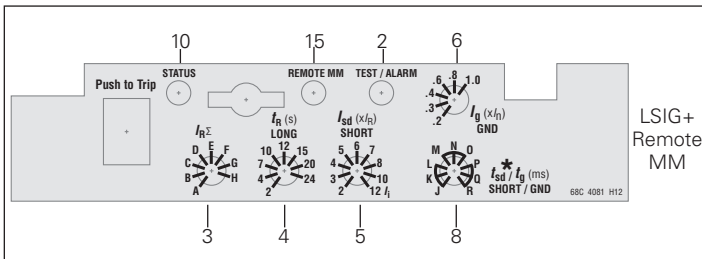
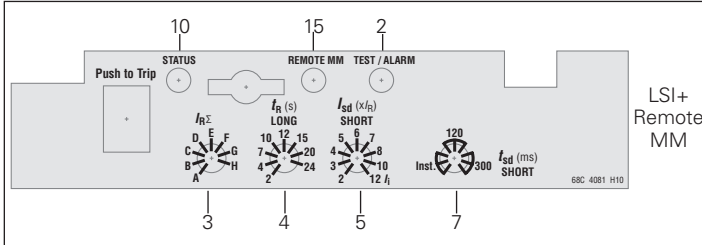

1. Test Port - A test port is built into each trip unit to allow use of a functional test kit. The test kit performs a test of the Long Delay, Short Delay and Ground Fault functions. (Plug-In Test Kit Catalog #MTST120V)
2. Test LED - To be used with a no trip functional test. This LED is a dual function light. The LED is used as a no trip indicator when using the test port. In normal modes, this LED indicates a high load alarm. It will light if the continuous current is 105% of the I_r Setting and must be present for a 38 second duration.
3. I_r - Continuous current setting - In accordance with standards requirements, the trip unit initiates a trip of the circuit breaker within 2 hours for an overload of 135% and will trip as a function of I^2t for higher currents. Continuous current values for each lettered setting are indicated by the chart displayed on the left side of the trip unit label.
4. t_r - The number of seconds required to trip @ $6 \times I_r$, i.e. $I_r - 250A$, $t_r - 2$ sec, load current - 1500A (6X). The breaker will trip in 2 seconds.
5. I_{sd} - Setting in multiples of I_r for short circuit conditions that exceed the short delay pick-up setting, the trip unit initiates a trip after a predetermined delay.

Note: In addition to the short delay trip function, there is a fixed instantaneous override for the 400A, 250A and 125A trip units. The override for the 400A is fixed at 4400A, the override for the 250A is fixed at 4200A and the override for the 125A is fixed at 3000A. If a fault current exceeds these override values, the breaker will trip instantaneously (in approximately 20 milliseconds or less).
6. The $I_g - (x I_n)$ switch is the ground fault pick-up switch. It is used on the LSG & LSI styles to set the ground fault pick-up as a percentage of I_n (frame current). For example, a 250A frame with an $I_g (x I_n)$ setting of 0.4 will provide a ground fault pick-up at 100A.
7. For the LSI style, the short delay time is a flat response determined by the t_{sd} switch settings of INST 120ms, or 300ms. For the LS styles, the short delay time is an I^2t function.
8. For the LSG style, the short delay is a flat response determined by the t_{sd}/t_g switch settings of INST, 120ms or 300ms. This switch is a dual switch that also determines the ground fault time settings of INST, 120ms or 300ms. For example, if the t_{sd}/t_g switch is set at position J, then both short delay time and ground fault time are at INST flat. As another example, set the t_{sd}/t_g switch at position L; the short delay flat time is INST and the ground fault flat time is at 300ms. The LSG label (8a) should be used in conjunction with the t_{sd}/t_g switch to set any one of nine possible combinations of short delay and ground fault flat times. The LSG label should be applied to the right side breaker frame nameplate.
9. For the LSG style, the short delay time is an I^2t function while the ground fault flat time is set by the t_g switch.
10. Status LED - A green status light indicates the operational status of the trip unit. If the load current exceeds approximately 20% of the maximum current rating (I_n) of the breaker, the status light will blink on for one second and off for one second.
11. The High Load Alarm Relay option or the Ground Fault Alarm Only option will provide a SPST contact closure when the trip unit current equals or is greater than 105% of I_n for a period of 38 seconds. If the current drops below the 105% value, the contact will open. The yellow and green wires that exit the right side of the breaker are the common (C) and normally open (NO) of this relay.

The Ground Fault Alarm Only option operates in a similar fashion, the SPST contact will close if the ground fault pick-up setting is exceeded and will open when below the ground fault pick-up setting. The yellow and green wires that exit the right side of the breaker are the common (C) and normally open (NO) of this relay.

12. The Ground Fault Relay option will provide a SPST contact closure immediately before the breaker will trip on a ground fault over current detect. This closure is momentary (50ms) and the customer must provide the necessary external circuitry in order to latch this signal. The yellow and green wires that exit the right side of the breaker are the common (C) and normally open (NO) of this relay.

Note: The High Load Alarm Relay can be selected with LS, LSI, and LSG, LSIG trip units. For the LSG and LSIG trip units, the High Load Alarm will function as normal. [11.] However, if the breaker trips due to a ground fault condition, the relay will respond with a ground fault alarm as indicated in [12.].

The Ground Fault Alarm Only can be selected for LSG and LSIG trip units only. This selection has precedence over all other relay functions.

When the Ground Fault Alarm Only is selected, the High Load Alarm Relay feature is not available.

Note: The contact ratings of the relay are: 2A at 30 VDC and 0.5 A at 125 VAC.

13. The Zone Selective Interlock (ZSI) option provides a wired method of coordinating Upstream and Downstream breakers. The coordinating signals are provided by the White\Red stripe (Zin), White\Black stripe (Zout), and Black (common ground) wires that exit the right side of the breaker.

A typical connection for a two breaker system is accomplished by connecting the Zout wire of the downstream breaker to the Zin of the upstream breaker. The common black wires of both breakers must also be connected.

If a high current fault is sensed from the load on the downstream breaker, both breakers will sense the fault. However, the downstream breaker will send the interlock signal to the upstream breaker informing it not to trip defined by the SD time settings of both breakers. This delay allows the downstream breaker to clear the fault without the upstream breaker tripping.

However, if for some reason the downstream breaker does not clear the fault in the set delay time, the upstream breaker will then clear the fault.

Note: This option must be ordered from the factory.

14. Zone Selective Interlocking is provided for the short delay and the ground fault delay tripping functions for improved system protection. The KES 310+ Trip Unit Zone Selective Interlocking feature is compatible with OPTIM and Digitrip Trip Units, Model 510 and higher. It is also compatible with Series G: RG, NG LG, JG, breakers, as well as, with FDE breakers.

The Zone Selective Interlocking feature is a means of communications over a pair of wires between two or more compatible trip units. Zone Selective Interlocking makes it possible for programmed trip unit settings to be altered automatically to respond to different fault conditions and locations, thereby localizing the effects of an interruption and providing positive coordination between circuit breakers.

Three wires exit the breaker with the following color code and function: White/Black Stripe=Zone Out, White/Red Stripe=Zone In, and Black=Common.

An example of a Zone Interlock system would be a KES 310+. A breaker used as the upstream breaker and a 225A FDE breaker used as the downstream breaker. The Zout wire (white/black stripe) of the 225A breaker would be connected to the Zin wire (white/red stripe) of the KES 310+ breaker. Also both common wired (black must be connected). There could be more breakers added in a similar fashion to form a zone of protection.

For faults outside the zone of protection, the trip unit of the circuit breaker nearest the fault sends an interlocking signal (Zout) to the trip unit of the up-stream circuit breaker. (Zin) This interlocking signal restrains immediate tripping of the upstream circuit breaker until its programmed coordination time is reached. Thus zone selective interlocking applied correctly can reduce damage due to circuit or ground fault conditions. A table of the settings of the two breakers versus the outcomes (Both Trip, Downstream (Dn) Trips) of the breakers is indicated below for the conditions mentioned in the table heading.

		Upstream		
		INST	120ms	300ms
Downstream	INST	Both	Dn 43ms	Dn 43ms
	120ms	Both	Dn 52ms	Dn 52ms
	300ms	Both	Dn 43ms	Dn 43ms

Note: A single Series G, FDE, or KD310+ breaker with the Zone Interlocking feature enabled will not trip at the programmed time settings, unless Self Interlocked. That is, the Zout wire should be connected to the Zin wire.

15. Remote Maintenance Mode (RMM) places the trip unit in the 2.5x instantaneous mode. For example, a 400 A (In) KD breaker with the switch set to 2.5x would trip instantaneously when the current exceeded 1000 A.

The Remote Maintenance Mode is enabled by applying 24VDC to the two wire cable that exits the left side of the breaker. The wires are color coded as follows:

Yellow=+24V and Black=common ground. A blue colored LED, on the trip unit lights when the breaker is the Remote Maintenance Mode.

The lighted blue LED indicates that the instantaneous setting of the Maintenance Mode is enabled. This setting corresponds to 2.5x of In. Turning the Isd switch on the trip unit has no effect on either the Maintenance Mode or the tsd\Tg settings while the blue LED is lit.

Also, a relay contact closure indicates that the Maintenance Mode has been enabled. The blue and red wires are the C and NO contacts of this relay. The relay has a dual function: 1) enable RMM and 2) provide a contact closure indication that RMM is enabled.

Both the yellow and black set of wires and the red and blue set of wires exit the left side of the breaker.

Note: The RMM and High Load\GFA Alarm contacts are rated at 2A at 30 VDC and 0.5A at 125 VAC.

3. Neutral Current Sensor Installation

Ground fault trip units are supplied from the factory with pigtail lead connections for a neutral current sensor (white and grey wires). A neutral current sensor shown in Figure 10 is available. Series G Ground Fault Trip Units detect ground fault currents through Residual Sensing. They are not designed to use source ground or zero sequence ground fault sensing methods. If the system neutral is grounded, but no phase to neutral loads are used, the neutral current sensor is not necessary. In that case, the white and grey leads on the trip should be cut off before installation. If the system neutral is grounded and phase to neutral loads are used, then the neutral current sensor must be used. It should be connected to the breaker according to Figure 11. It has the same turns ratio as the phase current sensors in the trip unit.

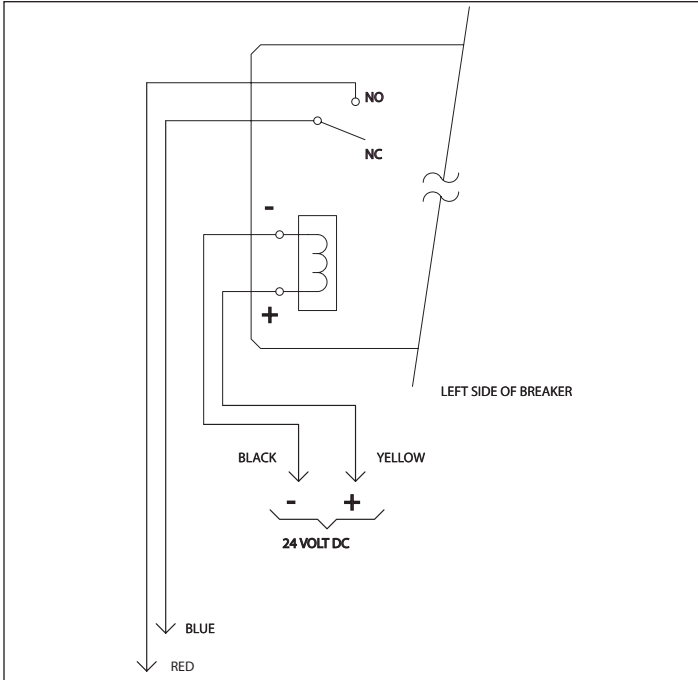

Figure 9. Remote Maintenance Mode Wiring Diagram.

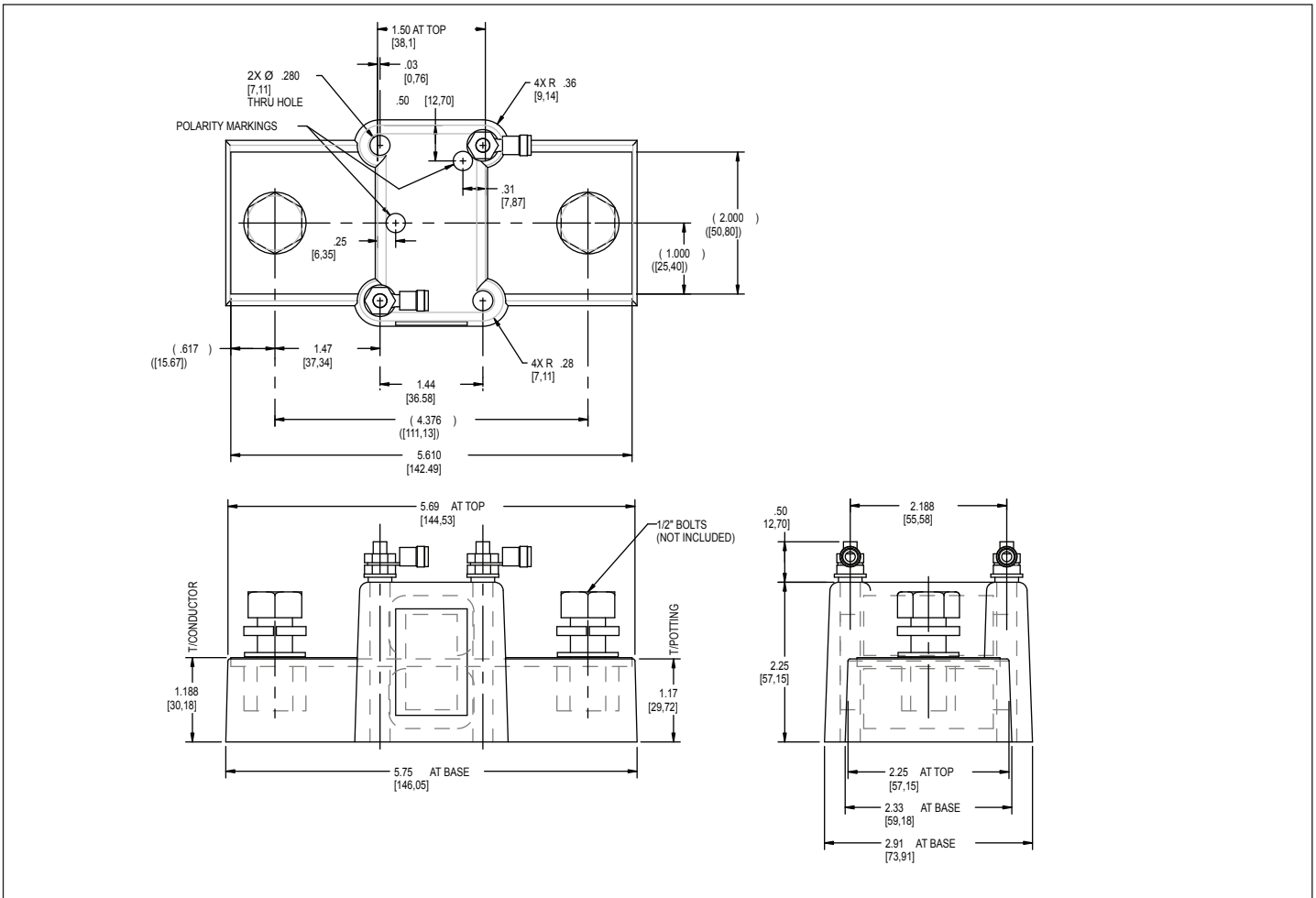

Figure 10. Neutral Current Sensor.

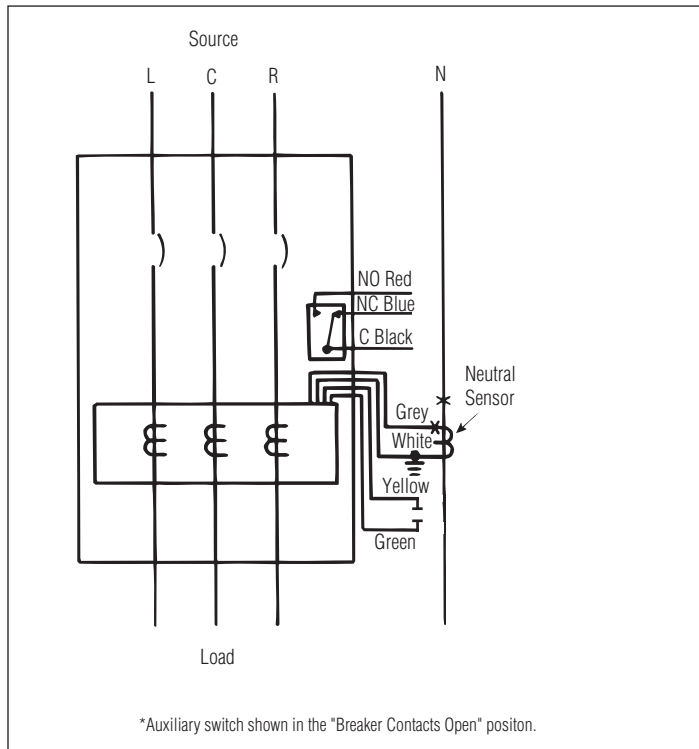

Figure 11. Neutral and Alarm Wiring Diagram.

NOTICE

THE POLARITY OF THE SENSOR CONNECTIONS IS CRITICAL. ALWAYS OBSERVE THE POLARITY MARKINGS ON THE INSTALLATION DRAWINGS. THE POLARITY MARKINGS ARE IDENTIFIED AS WHITE DOTS ON THE TRANSFORMERS. TO INSURE CORRECT GROUND FAULT EQUIPMENT PERFORMANCE, CONDUCT FIELD TESTS TO COMPLY WITH NATIONAL ELECTRIC CODE REQUIREMENTS UNDER ARTICLE 230-95-C.

Install the trip unit in the breaker frame as shown in Figures 1 - 4.

To install the ground fault alarm and neutral current sensor connector printed circuit board, an accessory switch must be installed in order to provide a support bracket. If the auxiliary switch supplied with the trip unit will be used, install it in the right pole of the breaker per IL 29C122. If an accessory other than the auxiliary switch supplied with the trip unit is to be used, install the accessory by using the appropriate instruction leaflet supplied with the accessory.

Insert the four-position connector on the printed circuit board into the receptacle in the trip unit and push the board down onto the bracket (see Figure 12).

If an accessory other than the auxiliary switch supplied with the trip unit is to be used, install the accessory by using the appropriate Instruction Leaflet.

The following types of internal accessories, which mount on the trip unit, are available for use. The number of the IL covering the installation of each accessory is shown.

- Alarm (Signal)/Lockout (ASL) SwitchI.L. 29C182
- Auxiliary SwitchI.L. 29C122
- Shunt Trip.....I.L. 29C144
- Low Energy Shunt TripI.L. 29C145
- Undervoltage Release Mechanism (Handle Reset).....I.L. 29C166

Note: See wiring instructions below for special restrictions on accessory wiring for ground fault breakers. Then install the ground fault alarm and neutral current sensor connector printed circuit board as described previously.

CAUTION

LEADS COULD BE DAMAGED IF IN CONTACT WITH MOVING PARTS. ACCESSORY WIRES SHOULD BE FORMED AND ROUTED TO CLEAR ALL MOVING PARTS.

When the appropriate accessory and the connector board are installed there are up to three sets of leads to be routed:

1. 2 leads (white and grey) for the neutral current sensor.
2. 2 leads (yellow and green) for the ground fault alarm relay
3. 3 leads (red, blue and black) for the accessory switch.

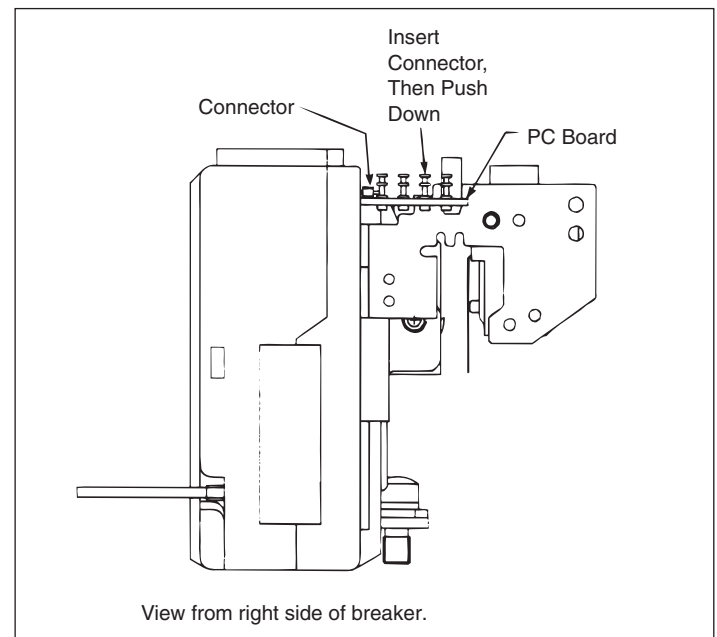

Figure 12. Installing Ground Fault Alarm and Current Sensor Connector PC Board.

If three sets of connections are required, it is not possible to have leads exiting the breaker on the opposite side. For rear exiting leads (preferred), thread the leads through the wiring troughs in the side of the circuit breaker case. For side exiting leads, use the slots in the side of the case. Use the trough or slot farthest from the trip unit for the auxiliary switch leads (red, blue and black), the center trough or slot for the neutral current sensor leads (white and grey), and the trough or slot closest to the trip unit for the alarm leads (yellow and green).

If only one or two sets of leads are required, they can be routed to the side or rear as above, or one set can be fed to the opposite side through the rear wiring trough. This set of leads should first be threaded through the center wiring trough in the side of the case, then through the rear wiring trough. Any other leads to be brought out should then be threaded through the wiring trough closest to the trip unit.

Finish the installation of the ground fault circuit breaker following Figure 5.

4. 100% Rated K-Frame Circuit Breakers

CKD and CHKD circuit breakers are suitable for continuous operation at 100% of the frame rating if used with CU only 90° C insulated wire and AL9CU terminals in an enclosure which measures at least 24" high x 15" wide x 6" deep. Ventilation is not required in an enclosure having these minimum dimensions.

The instructions for installation, testing, maintenance, or repair herein are provided for the use of the product in general commercial applications and may not be appropriate for use in nuclear applications. Additional instructions may be available upon specific request to replace, amend, or supplement these instructions to qualify them for use with the product in safety-related applications in a nuclear facility.

The information, recommendations, descriptions, and safety notations in this document are based on Eaton's experience and judgment with respect to Retrofitting of Power Breakers. This instructional literature is published solely for information purposes and should not be considered all-inclusive. If further information is required, you should consult an authorized Eaton sales representative.

The sale of the product shown in this literature is subject to the terms and conditions outlined in appropriate Eaton selling policies or other contractual agreement between the parties. This literature is not intended to and does not enlarge or add to any such contract. The sole source governing the rights and remedies of any purchaser of this equipment is the contract between the purchaser and Eaton.

NO WARRANTIES, EXPRESSED OR IMPLIED, INCLUDING WARRANTIES OF FITNESS FOR A PARTICULAR PURPOSE OR MERCHANTABILITY, OR WARRANTIES ARISING FROM COURSE OF DEALING OR USAGE OF TRADE, ARE MADE REGARDING THE INFORMATION, RECOMMENDATIONS, AND DESCRIPTIONS CONTAINED HEREIN. In no event will Eaton be responsible to the purchaser or user in contract, in tort (including negligence), strict liability or otherwise for any special, indirect, incidental or consequential damage or loss whatsoever, including but not limited to damage or loss of use of equipment, plant or power system, cost of capital, loss of power, additional expenses in the use of existing power facilities, or claims against the purchaser or user by its customers resulting from the use of the information, recommendations and description contained herein.

Eaton
Electrical Sector
1000 Eaton Boulevard
Cleveland, OH 44122
United States
877-ETN-CARE (877-386-2273)
Eaton.com

© 2013 Eaton
All Rights Reserved
Printed in USA
Publication No. IL012001EN / TBG001055
Part Number: IL012001ENH04
October 2013