

Instructions for Drilling and Assembling Flex Shaft™ Handle Mechanism for J-Frame Circuit Breakers, Molded Case Switches, and HMCPs

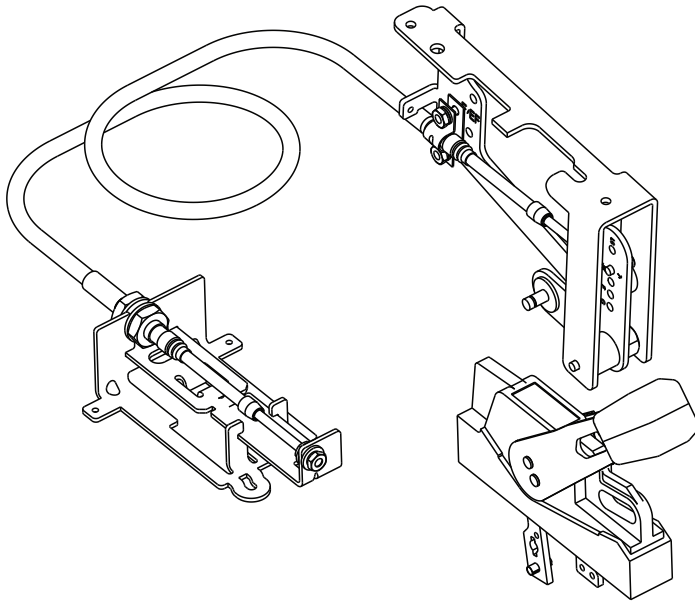

Contents

Description	Page
General Information	2
Installation	3
Alternate Installation	5
Adjustment Checklist.	5



WARNING

DO NOT ATTEMPT TO INSTALL OR PERFORM MAINTENANCE ON EQUIPMENT WHILE IT IS ENERGIZED. DEATH, SEVERE PERSONAL INJURY, OR SUBSTANTIAL PROPERTY DAMAGE CAN RESULT FROM CONTACT WITH ENERGIZED EQUIPMENT. ALWAYS VERIFY THAT NO VOLTAGE IS PRESENT BEFORE PROCEEDING WITH THE TASK, AND ALWAYS FOLLOW GENERALLY ACCEPTED SAFETY PROCEDURES. EATON IS NOT LIABLE FOR THE MISAPPLICATION OR MISINSTALLATION OF ITS PRODUCTS.

The user is cautioned to observe all recommendations, warnings, and cautions relating to the safety of personnel and equipment as well as all general and local health and safety laws, codes, and procedures.

The recommendations and information contained herein are based on Eaton experience and judgment, but should not be considered to be all-inclusive or covering every application or circumstance which may arise. If any questions arise, contact Eaton for further information or instructions.

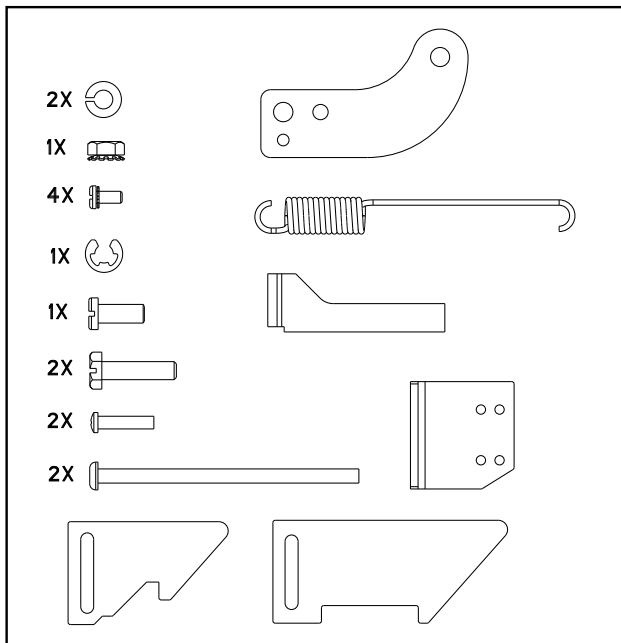

Fig. A Hardware Contents.

GENERAL INFORMATION

The Flex Shaft handle mechanism provides a means of externally operating the circuit breaker and can be applied to enclosures of varying heights and depths. The handle can be used with NEMA 1, 3R, and 12 enclosure applications, depending on the accessory components selected. An operating handle, flexible shaft, and mechanism are required for standard application. Eight lengths of shafts are available for use with the wide range of depths of various enclosures (3' through 10'). When selecting the length of the Flexible Shaft, ensure Minimum Bending Radius of 4 inches is maintained to operate properly. The standard method of shipment includes the mechanism preset at the factory. If minor field adjustments are required, see Fig. 1-3. For this publication, the term circuit breaker shall also include the molded case switch and motor circuit protector (HMCP).



WARNING

WHEN INSTALLING A NEW HANDLE MECHANISM, OR A NEW CIRCUIT BREAKER AND HANDLE MECHANISM IN AN EXISTING ELECTRICAL SYSTEM, MAKE SURE THERE IS NO VOLTAGE PRESENT WHERE WORK IS TO BE PERFORMED. SPECIAL ATTENTION SHOULD BE PAID TO REVERSE FEED APPLICATIONS TO ENSURE NO VOLTAGE IS PRESENT. THE VOLTAGE IN ENERGIZED, EQUIPMENT CAN CAUSE DEATH OR SEVERE PERSONAL INJURY.

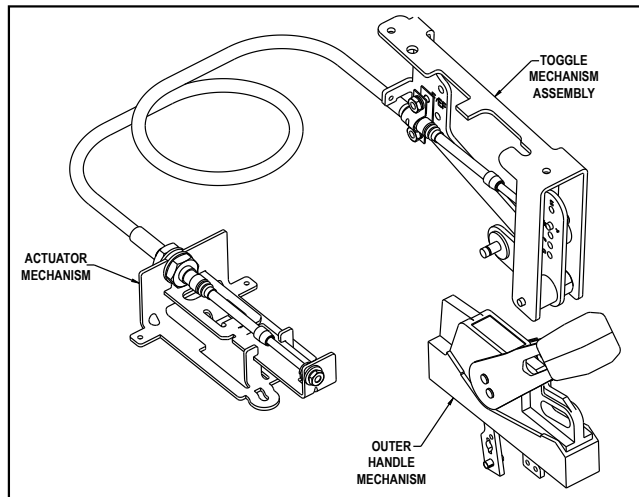

Fig. B Assembly Contents.

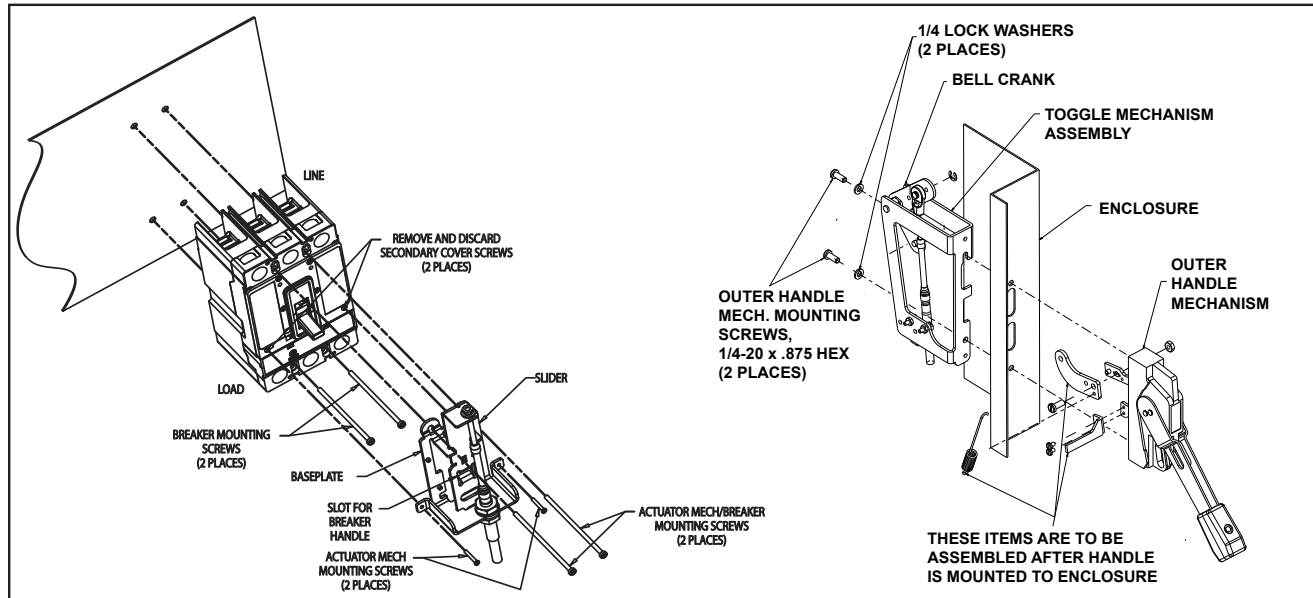

Fig. 1-1 Securing Actuator Mechanism to Breaker and Toggle Mechanism and Handle to Enclosure.

INSTALLATION

For assembly steps, refer to Fig 1-1, unless otherwise noted

1. Mount breaker with two, 4 x .7 x 90 breaker mounting screws. Install screws as shown.
2. Place the outer handle mechanism with attached gasket over the enclosure cutout. (For cut-out dimensions, refer to Fig 1-7). Insert the top 1/4-20 outer handle mech mounting screw and lockwasher through the enclosure and thread into the outer handle mechanism for a few turns, but not all the way.
3. Slide the toggle mechanism assembly over the top of the handle mounting screw. Insert the bottom outer handle mech- mounting screw and lockwasher through the toggle mechanism bracket, through the enclosure, into the handle. Fully tighten both mounting screws.
4. Insert the adapter link into the pin of the bell crank via the largest hole on the link. See Fig 1-4. Secure the adapter link by inserting the E-ring into the slot on the bell crank pin.
5. Rotate the bell crank towards the handle and rotate the handle to the On position. Align the adapter link and attach it to the actuator link using the 1/4-20 pan head screw and nut. See Fig 1-5.
6. Connect the long end of the spring through hole in adapter link. Hook the shorter end of the spring into the tab on the lower portion of the toggle mechanism. See Fig 1-6.
7. Mount door interlock hasp to handle using two #8-32 SEMS screws. See Fig. 1-2. Hasp orientation may be modified per customer requirements and enclosures.
8. Remove and discard the two secondary cover screws shown in Fig 1-1. Verify that breaker is in the trip position. Put outer handle mechanism in the trip position for ease of mounting actuator mechanism.
9. Place actuator mechanism around the front of the breaker. See Fig 1-1. Orient slider so that the slot captures the breaker handle. Fasten securely with the two 4-32 x .75 actuator mech/breaker screws and two 4 x .7 x 100 actuator mech/breaker mounting screws as shown.
10. Operate handle mechanism to ensure functionality. To operate, either close door or defeat door interlock lever.
11. If minor adjustments are necessary, refer to adjustment checklist on page 4.
12. Install appropriate door hardware (supplied). See Fig 1-7.

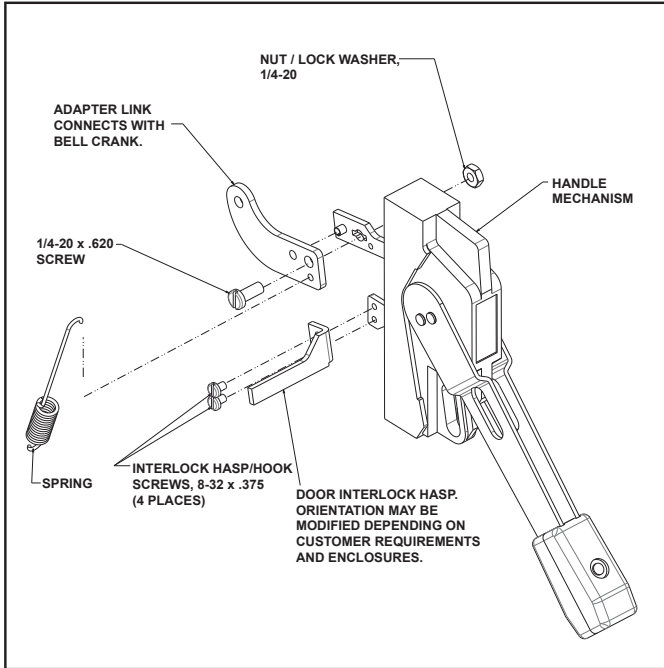

Fig. 1-2 Outer Handle Mechanism Assembly.

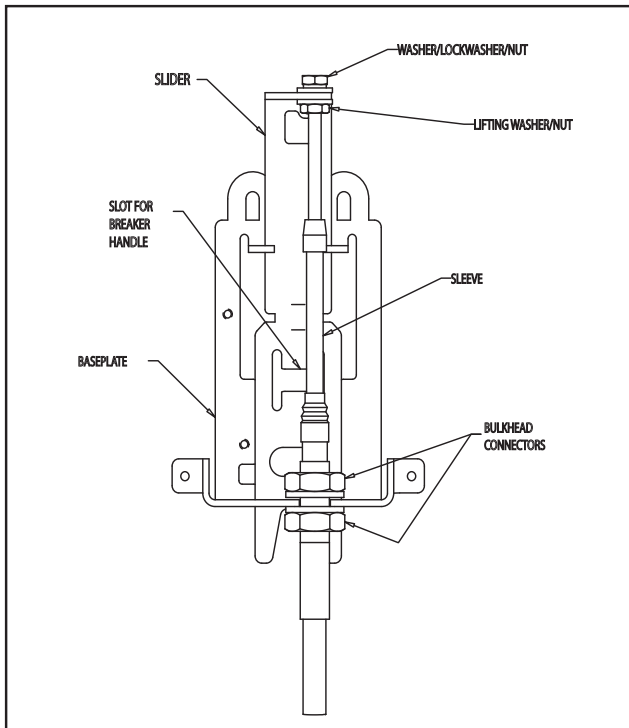

Fig. 1-3 J-Frame Actuator Mechanism.

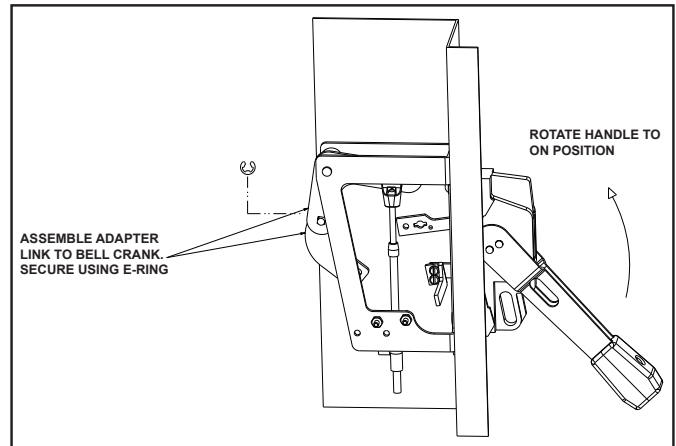

Fig. 1-4 Assembly of Adapter Link to Bell Crank.

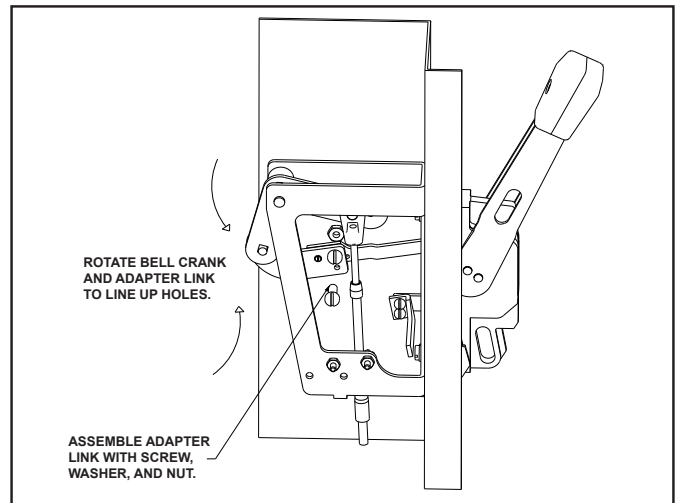

Fig. 1-5 Assembly of Adapter Link to Actuator Link.

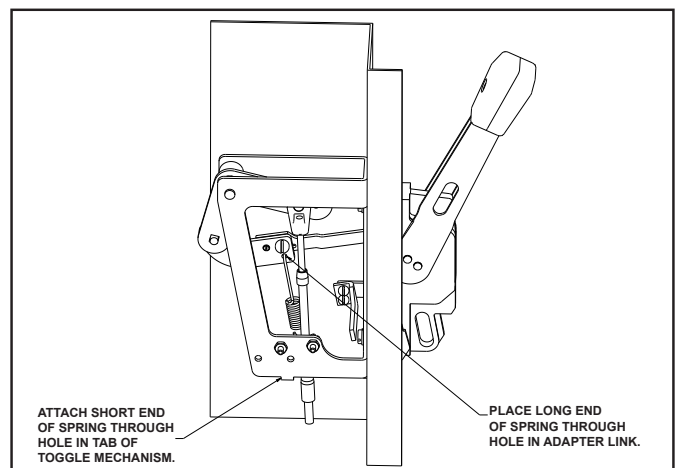

Fig. 1-6 Assembly of Spring to Toggle Mechanism.



WARNING

BEFORE ANY INSTALLATION OR MAINTENANCE IS PERFORMED, MAKE SURE THAT THE BREAKER IS NOT ENERGIZED.

ALTERNATE INSTALLATION

In the event a customer must disassemble the preassembled Flex Shaft handle mechanism, the procedure listed below must be followed before continuing with the "Installation" instructions. (See Fig. 1-3).

- A. Remove the flat washer, lockwasher, and nut assembly.
- B. Loosen bulkhead connectors and remove Flex Shaft from actuator mechanism. Shaft may not be routed as required.
- C. Place circuit breaker in the ON position.
- D. Place the operating handle in the full ON position.
- E. Replace Flex Shaft through the actuator mechanism. Center the bulkhead connectors on the threaded portion and tighten to approximately 70 in-lb.
- F. Place slot in Handle Pivot Bracket over the breaker handle while still in the ON position. Turn the lifting washer/nut until flush against the slider plate.
- G. Replace the flat washer, lockwasher, and nut assembly for the Flexible Shaft assembly. Tighten both nuts to approximately 45 in-lb.
- H. Check operation of mechanism for ON, OFF, and reset. Check the reset position of the actuator mechanism, that the lifting nut and sleeve of shaft do not come in contact with each other (see Fig. 1-3). If they do, move bulkhead connectors accordingly. If mechanism functions incorrectly, repeat procedure or go to Adjustment Checklist.

ADJUSTMENT CHECKLIST

Situation:
Breaker turns ON and OFF, but will not Reset when tripped.

Adjustment:
Loosen the lifting washer/nut while tightening the washer/lockwasher/nut, two or three turns should be sufficient (see Fig. 1-3).

Note: Check the reset position of the actuator mechanism, that the lifting nut and sleeve of shaft do not come into contact with each other (Fig. 1-3) If they do, move bulkhead connectors accordingly.

Situation:
Breaker Resets after tripping, but does not turn ON.

Adjustment:
Loosen the washer/lockwasher/nut on the end of the shaft while tightening the lifting washer/nut until breaker turns on with positive action. Tighten both nuts and recheck for ON, OFF, and Reset positions (Fig. 1-3).

Note: Be certain after adjustment to have a minimum of 1 thread past the washer/lockwasher/nut assembly (Fig. 1-3).

If any other adjustment problems should arise, contact your local Eaton representative.

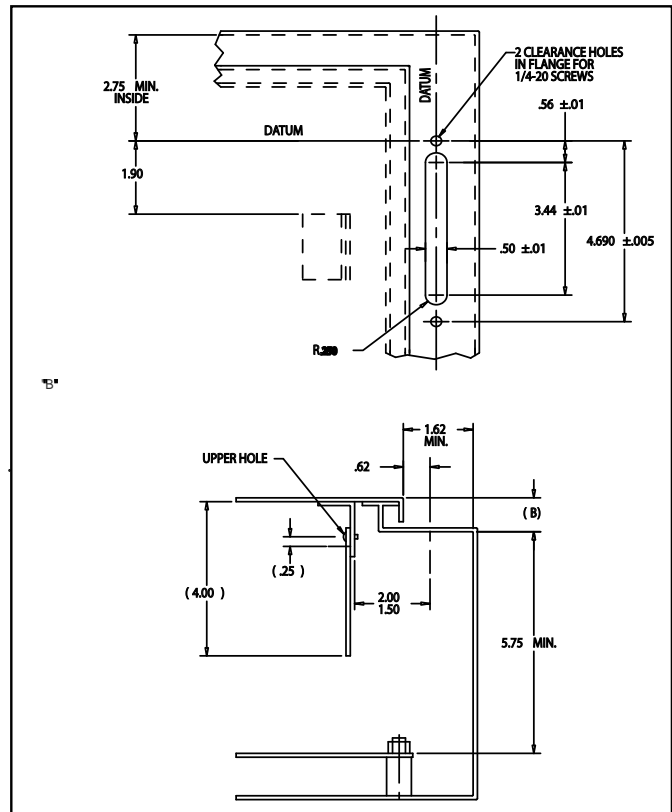

Fig. 1-7 Flange Drilling Plan for Handle and Interlock Blade Mounting Dimensions.

Notes:

Notes:

The instructions for installation, testing, maintenance, or repair herein are provided for the use of the product in general commercial applications and may not be appropriate for use in nuclear applications. Additional instructions may be available upon specific request to replace, amend, or supplement these instructions to qualify them for use with the product in safety-related applications in a nuclear facility.

This Instruction Booklet is published solely for information purposes and should not be considered all-inclusive. If further information is required, you should consult an authorized Eaton sales representative.

The sale of the product shown in this literature is subject to the terms and conditions outlined in appropriate Eaton selling policies or other contractual agreement between the parties. This literature is not intended to and does not enlarge or add to any such contract. The sole source governing the rights and remedies of any purchaser of this equipment is the contract between the purchaser and Eaton.

NO WARRANTIES, EXPRESSED OR IMPLIED, INCLUDING WARRANTIES OF FITNESS FOR A PARTICULAR PURPOSE OR MERCHANTABILITY, OR WARRANTIES ARISING FROM COURSE OF DEALING OR USAGE OF TRADE, ARE MADE REGARDING THE INFORMATION, RECOMMENDATIONS, AND DESCRIPTIONS CONTAINED HEREIN.

In no event will Eaton be responsible to the purchaser or user in contract, in tort (including negligence), strict liability or otherwise for any special, indirect, incidental or consequential damage or loss whatsoever, including but not limited to damage or loss of use of equipment, plant or power system, cost of capital, loss of power, additional expenses in the use of existing power facilities, or claims against the purchaser or user by its customers resulting from the use of the information, recommendations and description contained herein.

Eaton Corporation
Electrical Sector
1111 Superior Ave.
Cleveland, OH 44114
United States
877-ETN-CARE (877-386-2273)
Eaton.com

© 2013 Eaton Corporation
All Rights Reserved
Printed in USA
Publication No. IL0510TE0005 / TBG001063
Part No. IL0510TE0005H03
February 2013