



Cutler-Hammer

## Installation Instructions for Undervoltage Release Mechanism (Handle Reset) for JDB, JD, HJD, JDC, JW, HJW, JWC Circuit Breakers, Molded Case Switches, and J-Frame Motor Circuit Protectors (MCP)



### WARNING

DO NOT ATTEMPT TO INSTALL OR PERFORM MAINTENANCE ON EQUIPMENT WHILE IT IS ENERGIZED. DEATH, SEVERE PERSONAL INJURY, OR SUBSTANTIAL PROPERTY DAMAGE CAN RESULT FROM CONTACT WITH ENERGIZED EQUIPMENT. ALWAYS VERIFY THAT NO VOLTAGE IS PRESENT BEFORE PROCEEDING WITH THE TASK, AND ALWAYS FOLLOW GENERALLY ACCEPTED SAFETY PROCEDURES.

CUTLER-HAMMER IS NOT LIABLE FOR THE MISAPPLICATION OR MISINSTALLATION OF ITS PRODUCTS.

The user is cautioned to observe all recommendations, warnings, and cautions relating to the safety of personnel and equipment as well as all general and local health and safety laws, codes, and procedures.

The recommendations and information contained herein are based on Cutler-Hammer experience and judgement, but should not be considered to be all-inclusive or covering every application or circumstance which may arise. If any questions arise, contact Cutler-Hammer for further information or instructions.

### 1. INTRODUCTION

#### General Information

The undervoltage release mechanism (UVR) (Fig. 1-1) monitors a voltage (typically a line voltage) and trips the circuit breaker when the voltage falls to between 70 and 35 percent of the solenoid coil rating. The UVR consists of a continuous rated solenoid with a plunger and reset lever assembled to a plug-in module. The plug-in module is mounted in slots in the top of the trip unit and occupies the accessory cavity in the circuit breaker frame. The reset lever resets the UVR when normal voltage is restored and the circuit breaker handle is moved to the reset (extreme OFF) position. With no voltage applied to the UVR, the circuit breaker contacts will not touch when a closing operation is attempted.

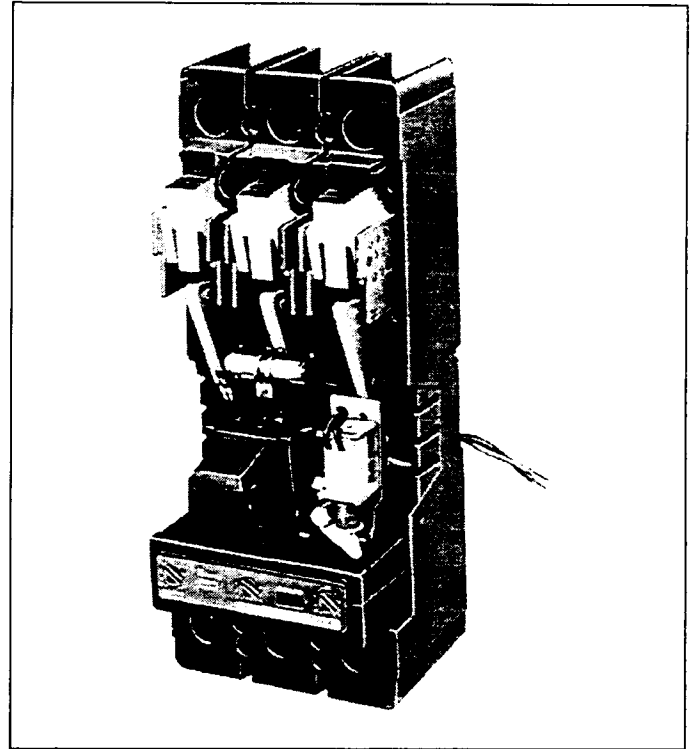

Fig. 1-1. Undervoltage Release Mechanism (Handle Reset) Installed in J-Frame Circuit Breaker

The UVR is available with several voltage ratings for most AC and DC requirements. Table 1-1 and 1-2 list application and electrical rating data for the UVR.

Depending on the model ordered, connections for the UVR are in one of four forms. The standard wiring configuration is pigtail leads exiting the rear of the base directly behind the UVR. Optional configurations include a terminal block mounted on the same side of the base as the accessory, leads exiting the side of the base where the accessory is mounted, and leads exiting the rear of the base on the side opposite the accessory. The 18-inch long pigtail leads are color coded for identification; the terminal block terminals are labeled. For allowable locations of all accessories, refer to Frame Book 29-102.

**Note:** When the walking beam interlock is used with the circuit breaker, the rear trough cannot be used for accessory pigtail leads.

This instruction leaflet (IL) gives detailed procedures to install the UVR.

## 2. INSTALLATION

**Note:** The UVR can be field-installed in JD, HJD, and JDC circuit breakers under UL File E64983.

The UVR can be field-installed in JW, HJW, and JWC circuit breakers.

For sealed circuit breakers (JDB), Underwriters Laboratories, Inc. UL489 requires that internal accessories be installed at the factory. The UVR is listed for factory installation under UL file E7819.

Where local codes and standards permit and UL listing is not required, internal accessories can be field-installed in JDB sealed circuit breakers. In this case, UL listing becomes invalid and the label should be removed.

Before attempting to install the UVR, check that the catalog number is correct and rating of the accessory satisfies the job requirements.

The UVR, as shown in kit form in Fig. 2-1, can be installed in the right or left accessory mounting cavity of a 2-, 3-, or 4-pole circuit breaker with a JT (fixed thermal) or JTA (adjustable thermal) trip unit, and in the left pole of circuit breakers with a JS (electronic) trip unit. If a UVR is to be used, it must be installed in the circuit breaker before the circuit breaker is mounted in an electrical system. To install the UVR, perform the following procedures:

**Note:** A circuit breaker that is mounted in an electrical system must be removed to install the accessory. To ensure correct accessory installation, the circuit breaker must be placed, after removal, on a horizontal surface with the switch facing upward.

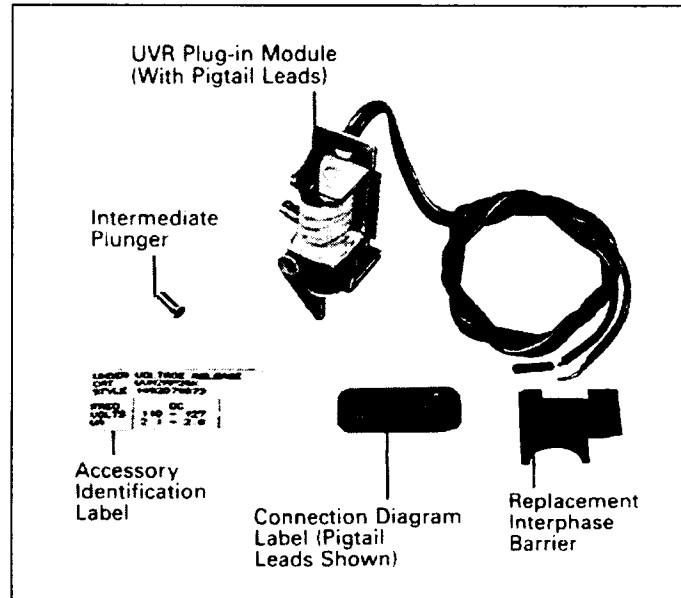

Fig. 2-1. Undervoltage Release Mechanism (Handle Reset) Kit



## WARNING

**BEFORE REMOVING A CIRCUIT BREAKER INSTALLED IN AN ELECTRICAL SYSTEM, MAKE SURE THE CIRCUIT BREAKER IS SWITCHED TO THE OFF POSITION AND THERE IS NO VOLTAGE PRESENT WHERE WORK IS TO BE PERFORMED. SPECIAL ATTENTION SHOULD BE PAID TO REVERSE FEED APPLICATIONS. THE VOLTAGES IN ENERGIZED EQUIPMENT CAN CAUSE DEATH OR SEVERE PERSONAL INJURY.**

**Note:** For a new circuit breaker installation, trip unit must be installed in circuit breaker before attempting to install a UVR. Refer to I.L. 29C600, I.L. 29C601, or I.L. 29C602 for instructions on how to install trip unit.

2-1. Switch circuit breaker to OFF position.

**Note:** Molded case switch trip units are not equipped with a Push-to-Trip button. For molded case switches, omit step 2-2.

2-2. Press PUSH-TO-TRIP button on the circuit breaker to trip the operating mechanism.

2-3. Disconnect and remove circuit breaker from installation and terminal connections.

2-4. Remove cover screws and cover.

**Note: To install UVR, circuit breaker operating mechanism must be in tripped position.**

2-5. For molded case switches (catalog suffix N or K designation), locate recessed hole in either of the trip unit outer poles (Fig. 2-2). Push intermediate plunger supplied with UVR in one hole to trip the molded case switch. Remove plunger to prevent it falling out of recessed hole in trip unit and into molded case switch mechanism.



## WARNING

**DO NOT RESET CIRCUIT BREAKER AFTER MOLDED HANDLE IS REMOVED. CRADLE RESET PIN MAY FLY OUT IF MECHANISM IS TRIPPED, CAUSING INJURY.**

**Note: The UVR must be installed with circuit breaker handle removed.**

2-6. Remove handle-retaining screw and molded handle from handle arm. (See Fig. 2-3). The molded handle should lift vertically off of the handle arm.

2-7. Remove interphase barrier between accessory mounting cavity and operating mechanism on the side of the breaker where the UVR is to be installed. (See Fig. 2-3.)

2-8. Install notched replacement interphase barrier supplied with kit in base. (See Fig. 2-3.)

2-9. Install UVR as described in following steps (Fig. 2-4):

**Note: For UVR having rear or opposite-side exiting pigtail leads, thread leads through center trough in side of case before attempting to insert mounting bracket. Pigtail leads exiting in this manner must be eased through trough as mounting bracket is inserted into trip unit retaining slots. Use center slot for leads exiting the side of the circuit breaker.**

a. Position intermediate plunger in trip unit as shown in figure 2-3.

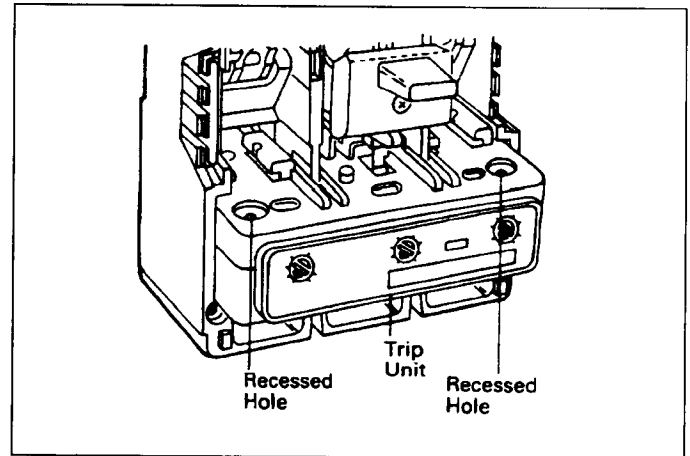

Fig. 2-2. Recessed Hole for Intermediate Plunger

b. Press intermediate plunger into recess in trip unit and ensure that it does not fall out. Grasp the UVR so that the face of the solenoid plunger is pointed toward the breaker trip unit (See Fig. 2-6). Compress the solenoid plunger and slide the UVR downward into the breaker so that the UVR mounting bracket fits into the slots in the trip unit. When the UVR has been fully inserted, the spring-loaded pin on the UVR bracket will "click" into a pin recess and lock the UVR in place. Test that the UVR is secure by gently pulling the UVR upward; it should not pull out the trip unit.

For terminal block assemblies, slide the terminal block into the mounting slot on the side of the circuit breaker base.

**Note: Before next step, be sure that replacement interphase barrier has been installed in correct accessory cavity side, and that cradle reset pin has not fallen out of retaining-slot in handle arm.**

2-10. Put molded handle on handle arm, and install retaining screw. (See Fig 2-3.)



## CAUTION

**PIGTAIL WIRES SHOULD BE FORMED AND ROUTED TO CLEAR ALL MOVING PARTS WHEN ACCESSORY IS PROPERLY INSTALLED. PIGTAIL LEADS COULD BE DAMAGED IF IN CONTACT WITH MOVING PARTS.**

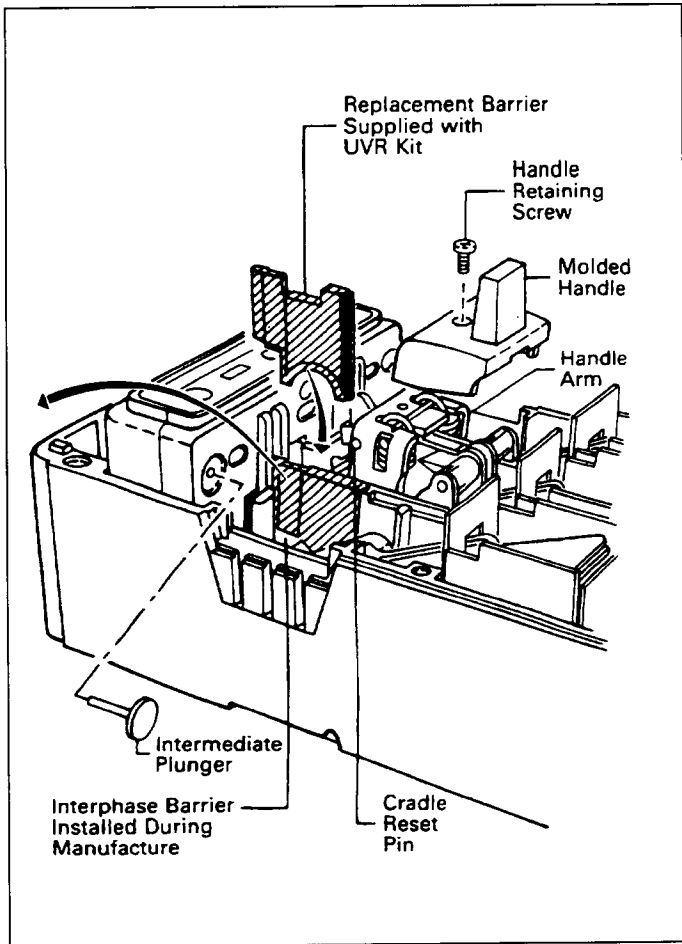

Fig. 2-3. Interphase Barrier Replacement

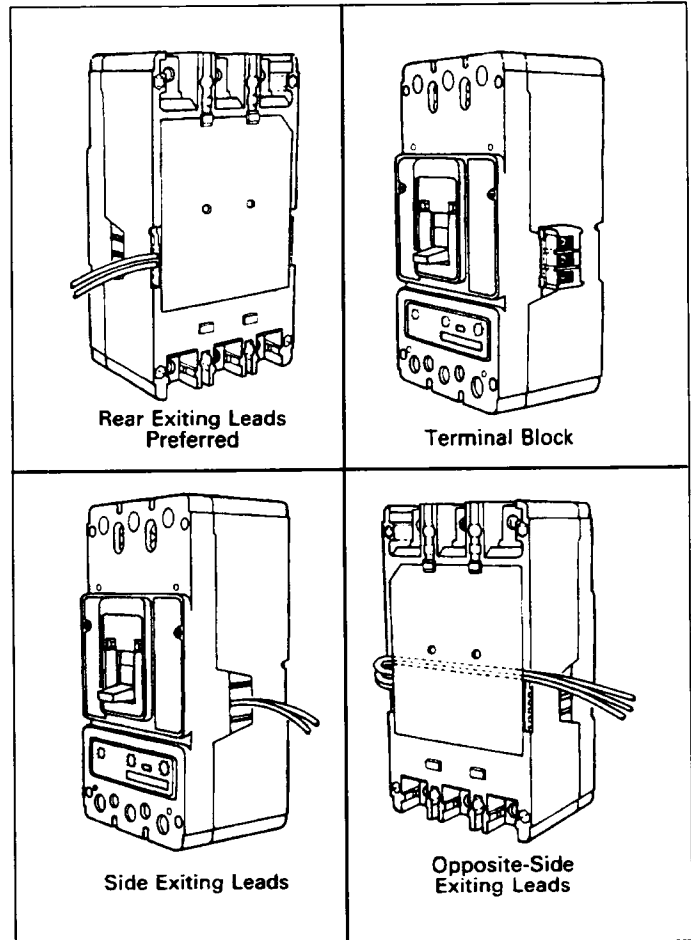

Fig. 2-5. Accessory Wiring Options

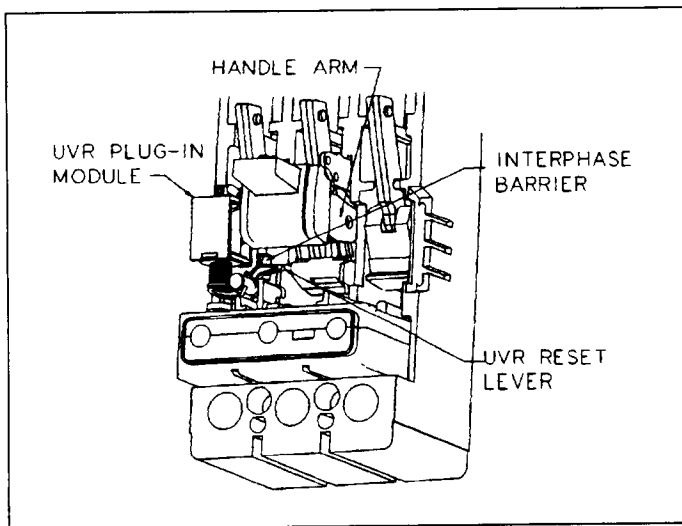

Fig. 2-4. UVR Installation

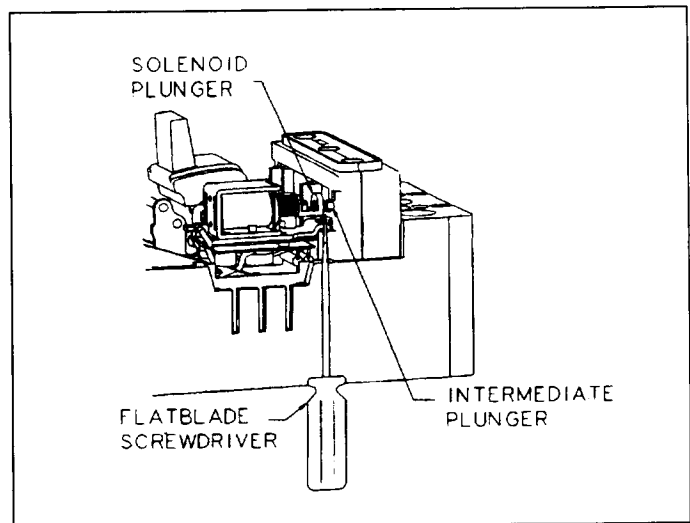

Fig. 2-6. Screwdriver Depressing Undervoltage Release Mechanism Solenoid Plunger

2-11. Route wiring to meet installation requirements (Fig. 2-5). If required, complete routing of leads to opposite side through rear wiring trough.

2-12. Perform mechanical check of UVR after installation circuit breaker but with no power connected.

- a. With circuit breaker still electrically isolated, reset the circuit breaker.
- b. Mechanical check. Using a small flat-blade screwdriver (Fig. 2-6), push in and hold solenoid plunger. Switch circuit breaker to ON. Release solenoid plunger and check that circuit breaker trips.
- c. Reset circuit breaker handle and check that handle arm moves reset lever to reset the solenoid plunger.
- d. If mechanical checks do not work, make sure UVR and intermediate plunger are correctly installed. If UVR and intermediate plunger appear to be correctly installed and problem persists, contact Cutler-Hammer.

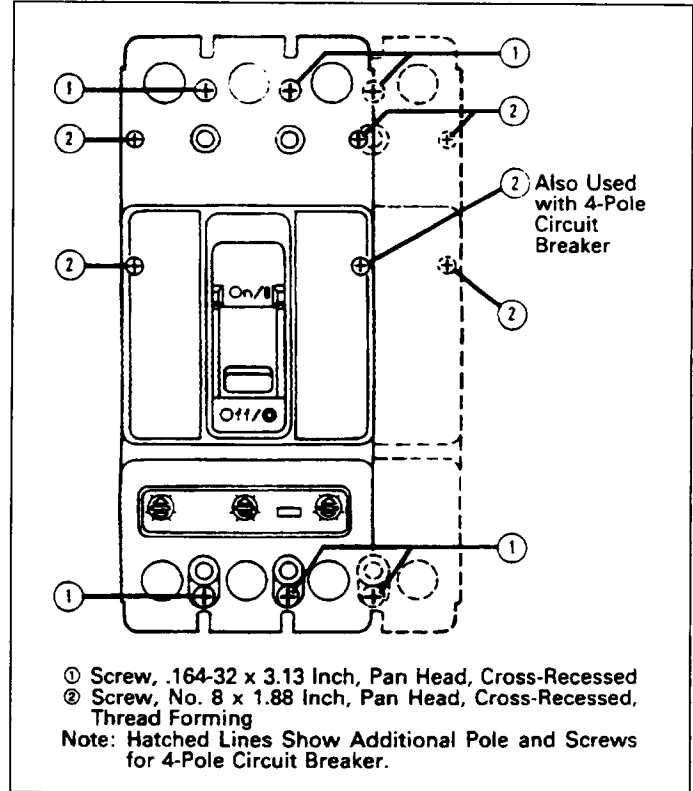

Fig. 2-7. Cover Screw Installation Positions



**CAUTION**

**WHEN INSTALLING CIRCUIT BREAKER COVER, MAKE SURE THAT ALL INTERNAL PARTS ARE IN PLACE:**

- **SLIDING HANDLE BARRIERS ARE INSTALLED SO THAT HANDLE OPENING IS ALIGNED WITH THE HANDLE.**
- **PIGTAIL LEADS ARE CLEAR OF COVER.**

**WHEN REMOVED AND REINSTALLED, THREAD-FORMING SCREWS TRY TO REFORM THE THREADS IN CIRCUIT BREAKER BASE. CARE SHOULD BE TAKEN EVERY TIME A THREAD-FORMING SCREW IS USED TO ENSURE THAT THE SCREW STARTS IN THE ORIGINAL THREADS. DAMAGED THREADS CAN RESULT IN IMPROPER CIRCUIT BREAKER COVER RETENTION.**

2-13. With circuit breaker handle in TRIPPED position and accessory pigtail leads (if used) routed as required, install circuit breaker cover. Secure with-

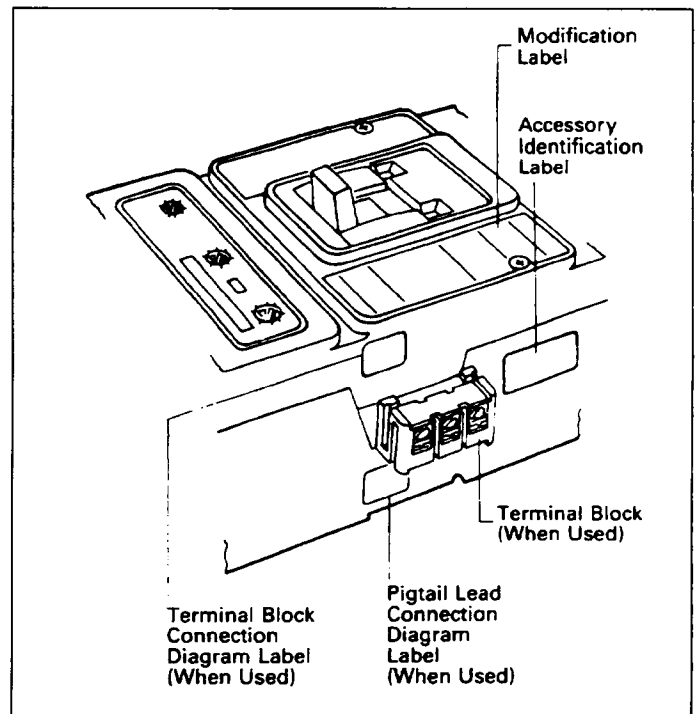

Fig. 2-8. Preferred Mounting Locations for Accessory Nameplate Labels

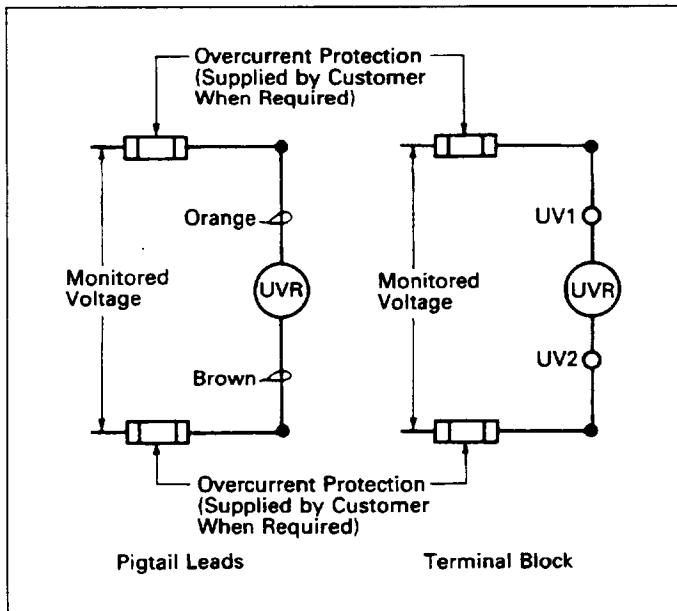

Fig. 2-9. Undervoltage Release Mechanism (Handle Reset) Connection Diagram

pan-head screws, followed by thread-forming screws as shown in Fig. 2-7.

- 2-14. JDB circuit breakers only: Remove and discard UL listing label.
- 2-15. Place accessory labels (Supplied with kit) on circuit breaker. (See Fig. 2-8.) Modification Label.

2-16. Where practical and after taking all necessary safety 2-18. Connect UVR to power source to be monitored. (See precautions, apply UVR rated voltage to UVR. Reset and close Fig. 2-9.) circuit breaker. Confirm that circuit breaker trips when voltage is removed.

2-17. Install circuit breaker.

**Note: Accessory labels show connection diagram for UVR contacts. Pigtail leads are color coded orange and brown.**

**No external resistors are required.**

2-18. Connect UVR to power source to be monitored. (See Fig. 2-9.)

Cutler-Hammer assumes no responsibility for malfunctioning accessories installed by the customer.



**CAUTION**

**IF UVR IS REMOVED FROM CIRCUIT BREAKER, INTERMEDIATE PLUNGER MUST ALSO BE REMOVED. FAILURE TO REMOVE INTERMEDIATE PLUNGER CAN RESULT IN EQUIPMENT DAMAGE.**

Table 1-1. AC (50/60 Hz) Undervoltage Release Mechanism (Handle Reset) Ratings ①

Catalog Suffix	Application Ratings	Electrical Operating Ratings					Approximate Operating Time (ms)			
	Voltage (V)	Supply Voltage (V)	Dropout Voltage (V) Min.	Pickup Voltage (V) Max.	VA	Min. ② UVR Response	Initiation ③ Circuit Breaker Contact Separation	Maximum Circuit Breaker Contact Opening	Dielectric Withstand Voltage (V) ④	
01	9	9	3.2	8.4	7.7	1.9	5	15	25	1018
02	12	12	4.2	8.4	10.2	1.9	5	15	25	1024
03	24	24	8.4	16.8	20.4	3.9	5	15	25	1048
05	48-60	48 60	21	33.6	40.8	2.5 3.8	5	15	25	1120
08	110-127	110 120 127	44.5	77	93.5	1.8 2.1 2.4	5	15 15 15	25	1500
11	208-240	208 220 240	85	145.6	176.8	2.7 3.1 3.8	5	25 25 25	35	1500
15	380-480	380 415 440 480	168	266	323	3.4 4.0 4.6 5.4	5	25 25 25	35	2500
18	525-600	525 550 600	210	367	446	4.5 5.0 5.8	5	25	35	2500

- ① Endurance — 6000 electrical operations plus 2000 mechanical operations
- ② UVR will override a momentary voltage dip up to the response time shown
- ③ Unlatching occurs 1 millisecond before circuit breaker contacts begin to separate
- ④ For 1 minute

Table 1-2. DC Undervoltage Release Mechanism (Handle Reset) Ratings ①

Catalog Suffix	Application Ratings	Electrical Operating Ratings					Approximate Operating Time (ms)			
		Supply Voltage (V)	Dropout Voltage (V) Min.	Pickup Voltage (V) Max.	VA	Min. ② UVR Response	Initiation ③ Circuit Breaker Contact Separation	Maximum Circuit Breaker Contact Opening	Dielectric Withstand Voltage (V) ④	
20	12	12	4.2	8.4	10.2	1.6	5	15	25	1024
21	24	24	8.4	16.8	20.4	3.1	5	15	25	1048
23	48-60	48 60	21	33.6	40.8	2.0 3.1	5	13	25	1120
26	110-125	110 120 125	44.5	77	93.5	1.6 1.9 2.2	6	13 15	25	1500
28	220-250	220 250	87.5	154	187	3.1 4.0	INST	10	20	1500

- ① Endurance — 6000 electrical operations plus 2000 mechanical operations  
 ② UVR will override a momentary voltage dip up to the response time shown  
 ③ Unlatching occurs 1 millisecond before circuit breaker contacts begin to separate  
 ④ For 1 minute

**Cutler-Hammer**

Pittsburgh, Pennsylvania U.S.A.

Style No. 6631C66H03 Effective December 1997  
 Printed in U.S.A./CCI

