

Installation Instructions for Low Energy Shunt Trip for JDB, JD, HJD, JDC, JW, HJW, JWC Circuit Breakers, Molded Case Switches, and J-Frame Motor Circuit Protectors (MCP)

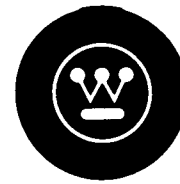

SERIES C[®]

I.L. 29C143
File 29-000

WARNING

DO NOT ATTEMPT TO INSTALL OR PERFORM MAINTENANCE ON EQUIPMENT WHILE IT IS ENERGIZED. DEATH, SEVERE PERSONAL INJURY, OR SUBSTANTIAL PROPERTY DAMAGE CAN RESULT FROM CONTACT WITH ENERGIZED EQUIPMENT. ALWAYS VERIFY THAT NO VOLTAGE IS PRESENT BEFORE PROCEEDING WITH THE TASK, AND ALWAYS FOLLOW GENERALLY ACCEPTED SAFETY PROCEDURES.

THE WESTINGHOUSE ELECTRIC CORPORATION IS NOT LIABLE FOR THE MISAPPLICATION OR MISINSTALLATION OF ITS PRODUCTS.

The user is cautioned to observe all recommendations, warnings, and cautions relating to the safety of personnel and equipment as well as all general and local health and safety laws, codes, and procedures.

The recommendations and information contained herein are based on Westinghouse experience and judgement, but should not be considered to be all-inclusive or covering every application or circumstance which may arise. If any questions arise, contact Westinghouse Electric Corporation for further information or instructions.

1. Introduction

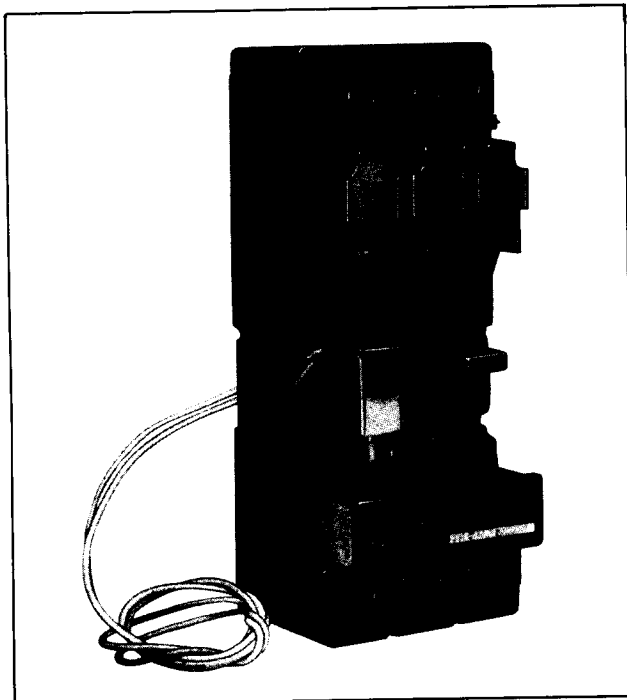

Fig. 1-1. Low Energy Shunt Trip Installed in J-Frame Circuit Breaker

General Information

The low energy shunt trip (LEST) (Fig. 1-1) is designed to interface with a customer ground fault detection circuit. The LEST consists of an intermittent-rated solenoid with a plunger and a reset lever assembled to a plug-in module. The plug-in module is mounted in slots in the top of the trip unit and occupies the accessory cavity in the circuit breaker frame. The reset lever resets the LEST when the trip signal is removed and the circuit breaker handle is moved to the reset (extreme OFF) position.

The LEST is designed to trip the circuit breaker when a 100 microfarad capacitor charged to 28 Vdc is discharged through the solenoid. Endurance for the LEST is 6000 electrical operations plus 2000 mechanical operations.

For this publication, the term circuit breaker shall include molded case switch and motor circuit protector.

Depending on the model ordered, connections for the low energy shunt trip are in one of four forms. The standard wiring configuration is pigtail leads exiting the rear of the base directly behind the LEST. Optional configurations include a terminal block mounted on the same side of the base as the accessory, leads exiting the side of the base where the accessory is mounted, and leads exiting the rear of the base on the side opposite the accessory. The 18-inch long pigtail leads are color coded for identification; the terminal block terminals are labeled. For allowable locations of all accessories, refer to Frame Book 29-102.

Note: When the walking beam interlock is used with the circuit breaker, the rear trough cannot be used for accessory pigtail leads.

This instruction leaflet (IL) gives detailed procedures to install the LEST.

2. Installation

Note: The LEST can be field installed in JD, HJD, and JDC circuit breakers under UL File E64983.

The LEST can be field-installed in JW, HJW, and JWC circuit breakers.

For sealed circuit breakers (JDB), Underwriters Laboratories, Inc. UL489 requires that internal accessories be installed at the factory. The LEST is listed for factory installation under UL file E7819.

Where local codes and standards permit and UL listing is not required, internal accessories can be field-installed in JDB sealed circuit breakers. In this case, UL listing becomes invalid and the label should be removed.

Before attempting to install the LEST, check that the catalog number is correct and that the rating of the accessory satisfies the job requirements.

The LEST, as shown in kit form in Fig. 2-1, can be installed in the right or left accessory mounting cavity of a 2-, 3-, or 4-pole circuit breaker with a JT (fixed thermal) or JTA (adjustable thermal) trip unit, and in the left pole of circuit breakers with a JS (electronic) trip unit. A LEST must be installed in the circuit breaker before the circuit breaker is mounted in an electrical system. To install the LEST, perform the following procedures:

Note: A circuit breaker that is mounted in an electrical system must be removed to install the accessory. To ensure correct accessory installation, the circuit breaker must be placed on a horizontal surface.

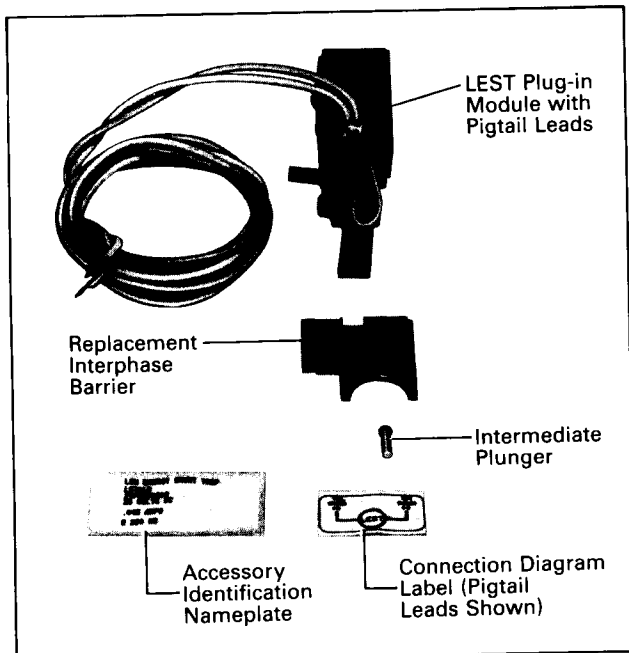

Fig. 2-1. Low Energy Shunt Trip Kit

WARNING

Before removing a circuit breaker installed in an electrical system, make sure the circuit breaker is switched to the OFF position and there is no voltage present where work is to be performed. Special attention should be paid to reverse feed applications. The voltages in energized equipment can cause death or severe personal injury.

Note: For a new circuit breaker installation, trip unit must be installed in circuit breaker before attempting to install a LEST. Refer to I.L. 29C600, I.L. 29C601, or I.L. 29C602 for instructions on how to install trip unit.

2-1. Switch circuit breaker to OFF position.

Note: Molded case switch trip units are not equipped with a Push-to-Trip button. For molded case switches, omit step 2-2.

2-2. Press PUSH-TO-TRIP button to trip the operating mechanism.

2-3. Disconnect and remove circuit breaker from installation and terminal connections.

2-4. Remove cover screws and cover.

Note: To install LEST, circuit breaker operating mechanism must be in tripped position.

2-5. For molded case switches (catalog suffix N or K designation), locate recessed hole in either of the trip unit outer poles (Fig. 2-2). Push intermediate plunger supplied with LEST in one hole to trip the molded case switch. Remove plunger to prevent it from falling out of recessed hole in trip unit and into molded case switch mechanism.

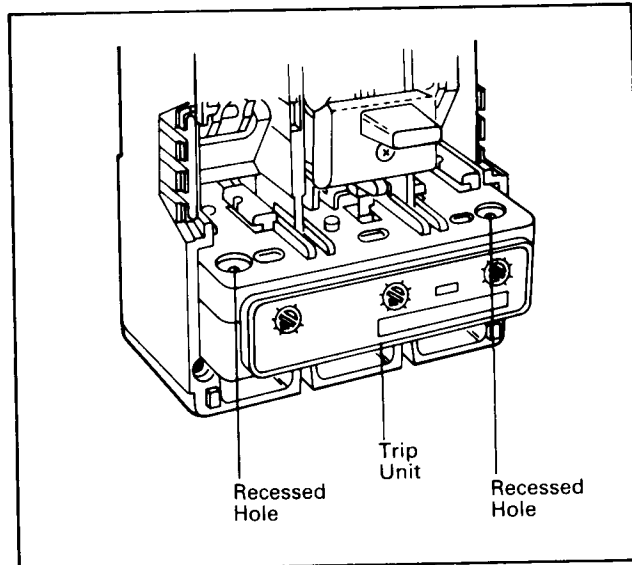

Fig. 2-2. Recessed Hole for Intermediate Plunger

WARNING

Do not reset circuit breaker after molded handle is removed. Cradle reset pin may fly out if mechanism is tripped, causing injury.

Note: The LEST must be installed with circuit breaker handle removed.

2-6. Remove handle-retaining screw and molded handle from handle arm. (See Fig. 2-3.)

2-7. Remove interphase barrier between accessory mounting cavity and operating mechanism. (See Fig. 2-3.)

2-8. Install replacement interphase barrier supplied with kit in base. (See Fig. 2-3.)

2-9. Install LEST as described in the following steps (Fig. 2-4.)

Note: For LEST having rear or opposite-side exiting pigtail leads, thread leads through center trough in side of case before attempting to insert mounting bracket. Pigtail leads exiting in this manner must be eased through trough as mounting bracket is inserted into trip unit retaining slots. Use center slot for leads exiting the side of the circuit breaker.

a. Position intermediate plunger in trip unit. Longer pin is for KS trip unit. Shorter pin is for KT trip unit.

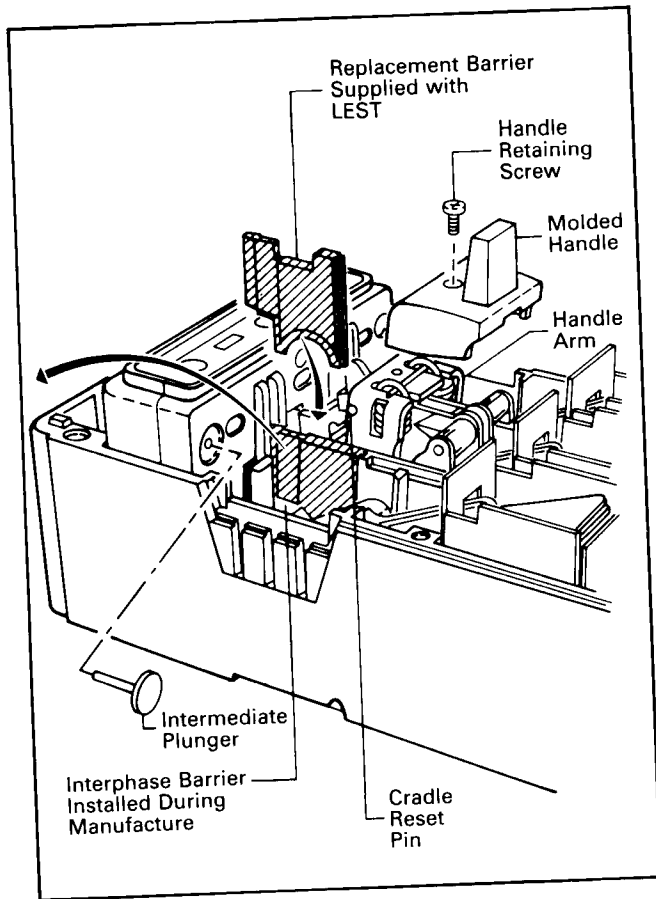

Fig. 2-3. Interphase Barrier Replacement

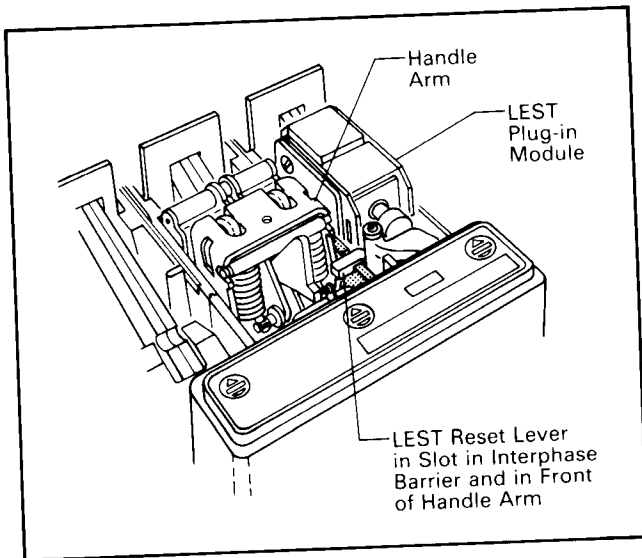

Fig. 2-4. LEST Installation

b. Press intermediate plunger into recess in trip unit, and hold in position. Slide LEST plug-in module into slots in trip unit (Fig. 2-4.) until spring-loaded retaining pin snaps into pin recess. For terminal block assemblies, slide terminal block into mounting slot on side of base as plug-in module is properly positioned.

Note: Before next step, be sure that replacement interphase barrier has been installed in correct accessory cavity side, and that cradle reset pin has not fallen out of retaining slot in handle arm.

2-10. Put molded handle on handle arm, and install retaining screw. (See Fig 2-3.)

CAUTION

Pigtail wires should be formed and routed to clear all moving parts when accessory is properly installed. Pigtail leads could be damaged if in contact with moving parts.

2-11. Route wiring to meet installation requirements (Fig. 2-5). If required, complete routing of leads to opposite side through rear wiring trough.

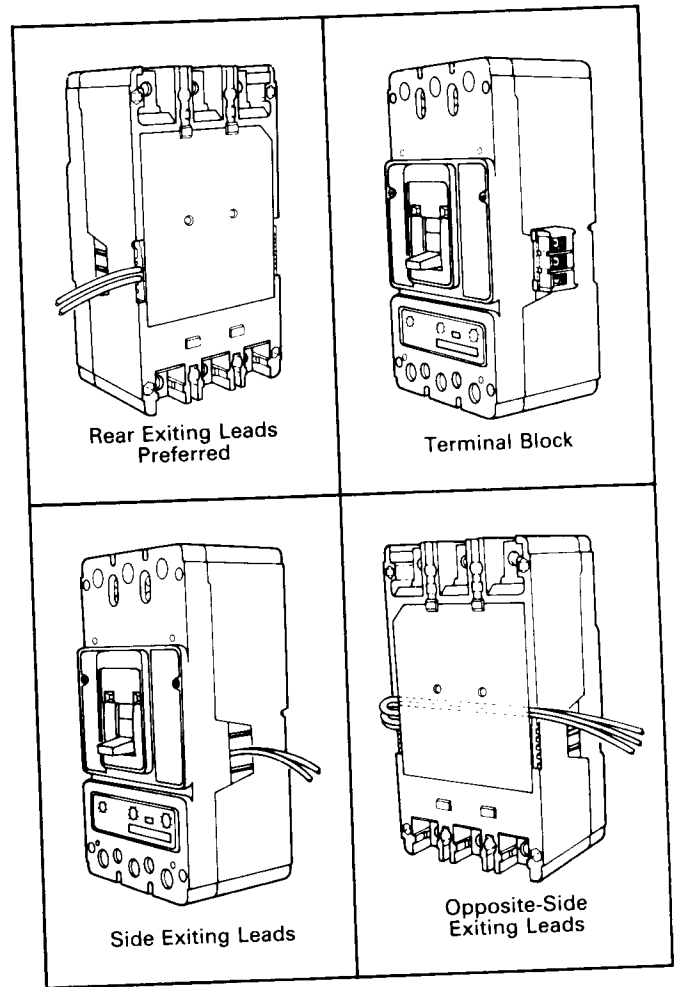

Fig. 2-5. Accessory Wiring Options

WARNING

When checking accessory, do not put fingers near moving parts inside circuit breaker case. Springs cause internal parts to move quickly and with force. Contact with moving parts can cause injury.

2-12. Perform mechanical check of LEST after installation:

- a. With circuit breaker still electrically isolated, reset the circuit breaker.

CAUTION

The solenoid plunger is held in the seated position by a permanent magnet. Light pressure, not to exceed two pounds, should be used to move plunger from the seated position.

- b. Position a small flat-blade screwdriver (Fig. 2-6) under the head of the solenoid plunger. Pry the plunger free from the seated position inside the solenoid and check that circuit breaker trips.

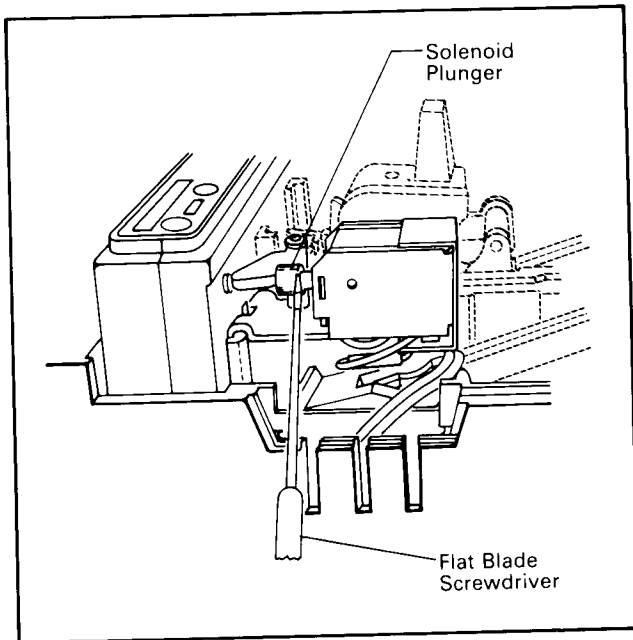

Fig. 2-6. Testing Operation of Solenoid Plunger

- c. Reset circuit breaker handle and check that handle arm moves the reset lever, and that solenoid plunger is pushed into solenoid and held by magnet.

- d. If mechanical checks do not work, make sure LEST and intermediate plunger are correctly installed. If LEST and intermediate plunger appear to be correctly installed and problem persists, contact Westinghouse.

CAUTION

When installing circuit breaker cover, make sure that all internal parts are in place:

- Sliding handle barriers are installed so that handle opening is aligned with the handle.
- Pigtail leads are clear of cover.

When removed and reinstalled, thread-forming screws try to reform the threads in circuit breaker base. Care should be taken every time a thread-forming screw is used to ensure that the screw starts in the original threads. Damaged threads can result in improper circuit breaker cover retention.

- 2-13. With circuit breaker handle in TRIPPED position and accessory pigtail leads (if used) routed as required, install circuit breaker cover. Secure with pan-head screws, followed by thread-forming screws as shown in Fig. 2-7.

- 2-14. Remove and discard UL listing label on JDB circuit breakers only.

- 2-15. Place accessory labels (supplied with kit) on circuit breaker. (See Fig. 2-8.)

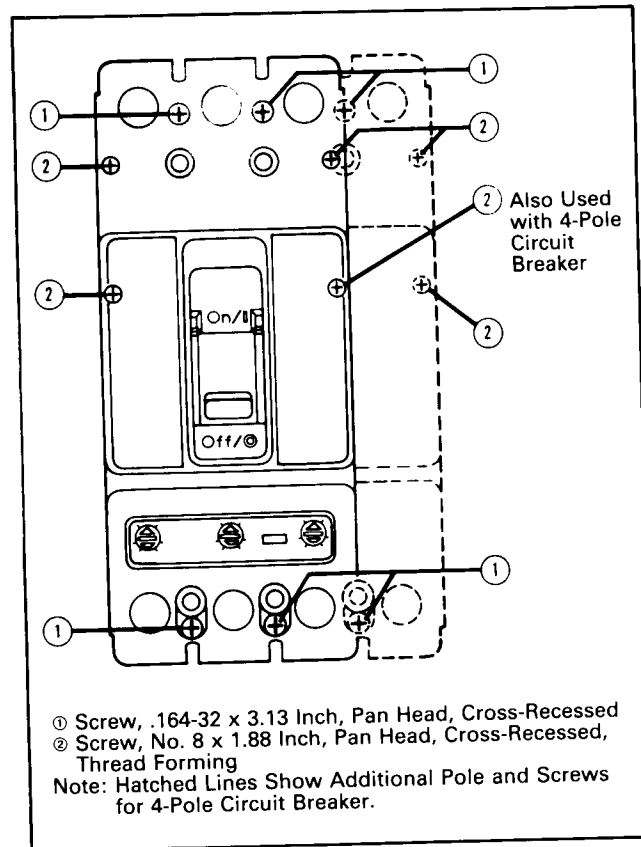

Fig. 2-7. Cover Screw Installation Positions

CAUTION

Solenoid is rated for intermittent duty. Continuous application of 24 Vdc will damage the solenoid.

- 2-16. Electrical check. Where practical and after taking all necessary safety precautions, connect yellow LEST lead to positive terminal of a DC power supply and white lead to ground. Reset and close circuit breaker. Confirm that circuit breaker trips when 24 Vdc (maximum pulse of one second) is applied to leads.

- 2-17. Install circuit breaker.

Note: Accessory labels show connection diagram for LEST contacts. Pigtail leads are color coded yellow and white.

- 2-18. Connect LEST to ground fault detection circuit to be monitored. (See Fig. 2-9.) Yellow lead is positive.

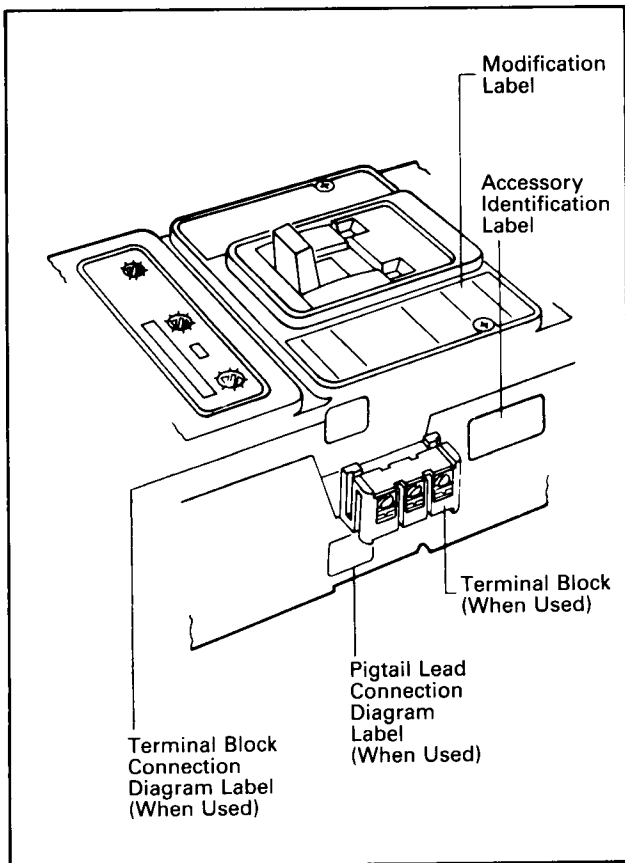

Fig. 2-8. Preferred Mounting Locations for Accessory Nameplate Labels

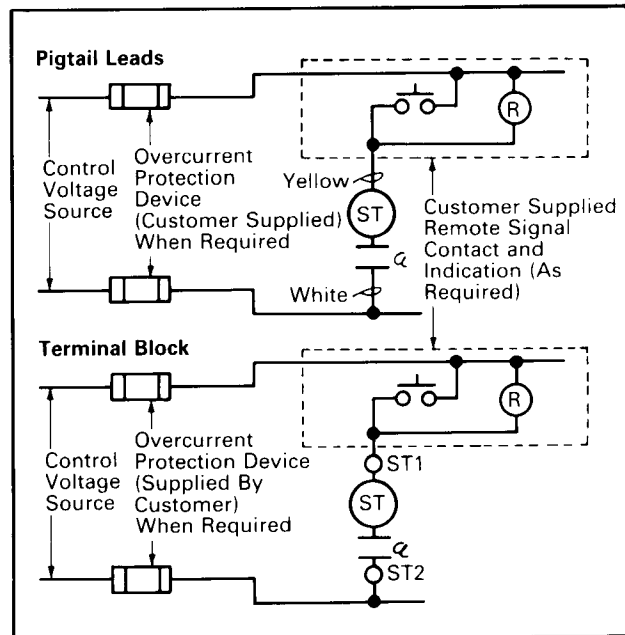

Fig. 2-9. Low Energy Shunt Trip Connection Diagram

Westinghouse assumes no responsibility for malfunctioning accessories installed by the customer.

CAUTION

If LEST is removed from circuit breaker, intermediate plunger must also be removed. Failure to remove intermediate plunger can result in equipment damage.