

Installation Instructions for Auxiliary Switch for JDB, JD, HJD, JDC, JW, HJW, JWC Circuit Breakers, Molded Case Switches, and J-Frame Motor Circuit Protectors



WARNING

DO NOT ATTEMPT TO INSTALL OR PERFORM MAINTENANCE ON EQUIPMENT WHILE IT IS ENERGIZED. DEATH, SEVERE PERSONAL INJURY, OR SUBSTANTIAL PROPERTY DAMAGE CAN RESULT FROM CONTACT WITH ENERGIZED EQUIPMENT. ALWAYS VERIFY THAT NO VOLTAGE IS PRESENT BEFORE PROCEEDING WITH THE TASK, AND ALWAYS FOLLOW GENERALLY ACCEPTED SAFETY PROCEDURES.

EATON IS NOT LIABLE FOR THE MISAPPLICATION OR MISINSTALLATION OF ITS PRODUCTS.

The user is cautioned to observe all recommendations, warnings, and cautions relating to the safety of personnel and equipment as well as all general and local health and safety laws, codes, and procedures. The recommendations and information contained herein are based on Eaton experience and judgement, but should not be considered to be all-inclusive or covering every application or circumstance which may arise. If any questions arise, contact Eaton for further information or instructions.

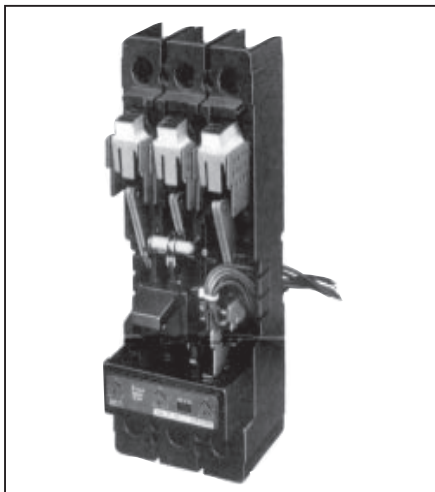

Fig. 1-1. Auxiliary Switch Installed in J-Frame Circuit Breaker

1. INTRODUCTION

General Information

The auxiliary switch (Fig. 1-1) indicates circuit breaker contacts status, and is used for remote signaling and system interlocking purposes. The switch consists of one or two single pole double-throw (SPDT) switches assembled to a plug-in module. The plug-in module is mounted in slots in the top of the trip unit; it occupies the accessory cavity in the circuit breaker frame, and is positioned so that the switch actuator arm rests against the molded crossbar. Each SPDT switch has one "a" and one "b" contact. When the molded crossbar is in the contacts-closed position, the "a" contact of each SPDT switch is closed and the "b" contact is open. When the molded cross bar is in the tripped or contacts-open position, the "a" contact is open and the "b" contact is closed.

Table 1-1 lists electrical rating data for the auxiliary switch.

Table 1-1. Auxiliary Switch Electrical Rating Data ① ② ③

Maximum Voltage (V)	Freq. Current (A)	Maximum Withstand Voltage (V)	Dielectric
600	50/60 Hz	6	2500
125	DC	0.5	
250	DC	0.25	

- ① Endurance: 6000 electrical operations plus 2000 " mechanical operations.
- ② Pigtail wire size No. 18 AWG (0.82 mm²).
- ③ Terminal block is listed for use with one or two No. 18 to No. 14 AWG solid or stranded copper wire. Torque is 7 lb in (0.8 N.m).
- ④ Noninductive load.

Depending on the model ordered, connections for the auxiliary switch are in one of four forms. The standard wiring configuration is pigtail leads exiting the rear of the base directly behind the accessory. Optional configurations include a terminal block mounted on the same side of the base as the accessory, leads exiting the side of the base where the accessory is mounted, and leads exiting the rear of the base on the side opposite the accessory. The 18-inch long pigtail leads are color coded for identification; identification labels are provided for pigtail leads and terminal block points. For allowable locations of all accessories, refer to Frame Book 29-102.

NOTICE

No more than three pigtail leads can be routed through the rear trough in the circuit breaker base. When the walking beam interlock is used with the circuit breaker, the rear trough cannot be used for accessory pigtail leads.

This instruction leaflet (IL) gives detailed procedures to install the auxiliary switch.

2. INSTALLATION

NOTICE

The auxiliary switch can be field-installed in JD, HJD, and JDC circuit breakers under UL File E64983.

The auxiliary switch can be field-installed in JW, HJW, and JWC circuit breakers.

For sealed circuit breakers, Underwriters Laboratories, Inc. UL489 requires that internal accessories be installed at the factory. The auxiliary switch is listed for factory installation under UL File E7819.

Where local codes and standards permit and UL listing is not required, internal accessories can be field installed in JDB sealed circuit breakers. In this case, UL listing becomes invalid and the label should be removed.

Before attempting to install the accessory, check that the catalog number is correct and that the rating of the accessory satisfies job requirements.

The auxiliary switch, shown in kit form in Fig. 2-1, can be installed in the right or left accessory mounting cavity of a 2-, 3-, or 4-pole circuit breaker. An auxiliary switch must be installed in the circuit breaker before the circuit breaker is mounted in an electrical system. To install the auxiliary switch, De the following procedures:

NOTICE

A circuit breaker that is mounted in an electrical system must be removed to install the accessory. To ensure correct accessory installation, the circuit breaker must be Placed on a horizontal surface.

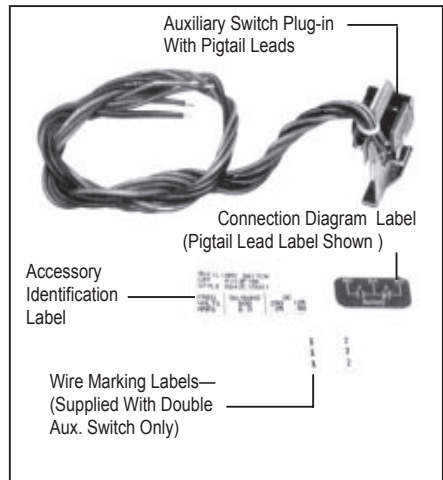

Fig. 2-1. Auxiliary Switch Kit



WARNING

BEFORE REMOVING A CIRCUIT BREAKER INSTALLED IN AN ELECTRICAL SYSTEM, MAKE SURE THE CIRCUIT BREAKER IS SWITCHED TO THE OFF POSITION AND THERE IS NO VOLTAGE PRESENT WHERE WORK IS TO BE PERFORMED. SPECIAL ATTENTION SHOULD BE PAID TO REVERSE FEED APPLICATIONS TO ENSURE NO VOLTAGE IS PRESENT. THE VOLTAGES IN ENERGIZED EQUIPMENT CAN CAUSE DEATH OR SEVERE PERSONAL INJURY.

- 2-1. Switch circuit breaker to OFF position.
- 2-2. Disconnect and remove circuit breaker from installation and terminal connections.

NOTICE

For new circuit breaker installation, trip unit must be installed in circuit breaker before attempting to install auxiliary switch. Refer to I.L. 29C600, I.L. 29C601, or I.L. 29C602 for instructions on how to install the trip unit.

- 2-3. Remove cover screws and cover.

NOTICE

For an auxiliary switch having rear or opposite side exiting pigtail leads, thread leads through center trough in side of case before attempting to insert mounting bracket. Pigtail leads exiting in this manner should be eased through trough as mounting bracket is inserted into trip unit retaining slots. Use center slot for leads exiting side of the circuit breaker.

2-4. Route wiring to meet installation requirements. (See Fig 2-2).

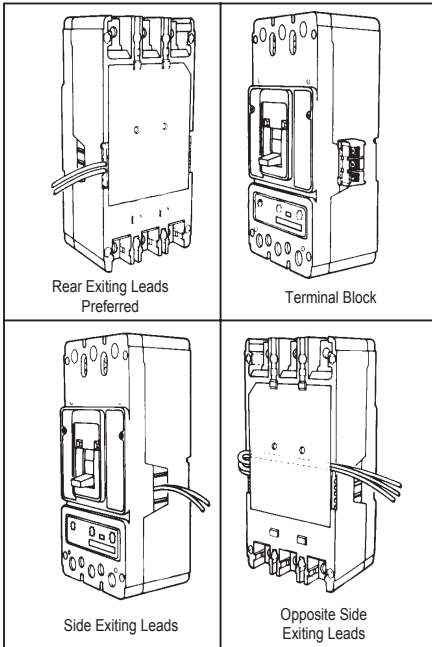

Fig. 2-2. Accessory Wiring Options



CAUTION

PIGTAIL WIRES SHOULD BE FORMED AND ROUTED TO CLEAR ALL MOVING PARTS WHEN ACCESSORY IS PROPERLY INSTALLED. PIGTAIL LEADS COULD BE DAMAGED IF IN CONTACT WITH MOVING PARTS

2-5. Insert the auxiliary switch as described in the following steps (Fig. 2-3):

- a. Slide auxiliary switch plug-in module into slots until

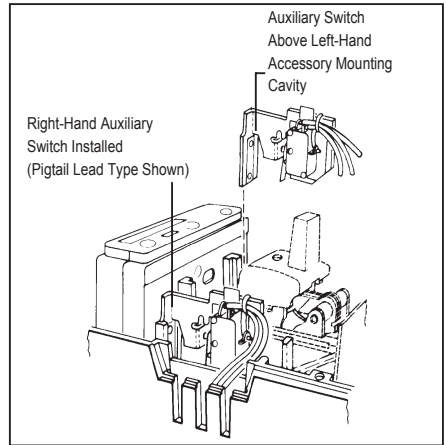

Fig. 2-3. Auxiliary Switch Installation Positions

spring loaded retaining pin snaps into pin recess. Auxiliary switch operating arm(s) must be between accessory operating projection on molded crossbar and arc extinguisher. For terminal block assemblies, slide terminal block into mounting slot on side of base as plug-in module is being positioned.

- b. If required, complete routing of leads to opposite-side through rear wiring trough.
- c. For double auxiliary switch pigtail leads, attach wire marking labels to bundle of three leads for each switch. (Markers designated 1 and 2 are provided.)



CAUTION

WHEN INSTALLING CIRCUIT BREAKER COVER, MAKE SURE THAT ALL INTERNAL PARTS ARE IN PLACE:

- SLIDING HANDLE BARRIERS ARE POSITIONED SO THAT THE HANDLE OPENING IS ALIGNED WITH THE HANDLE.
- PIGTAIL LEADS ARE CLEAR OF COVER.

WHEN REMOVED AND REINSTALLED, THREAD-FORMING SCREWS TRY TO REFORM THE THREADS IN THE CIRCUIT BREAKER BASE. CARE SHOULD BE TAKEN EVERY TIME A THREAD-FORMING SCREW IS USED TO ENSURE THAT THE SCREW STARTS IN THE ORIGINAL THREADS. DAMAGED THREADS CAN RESULT IN IMPROPER CIRCUIT BREAKER COVER

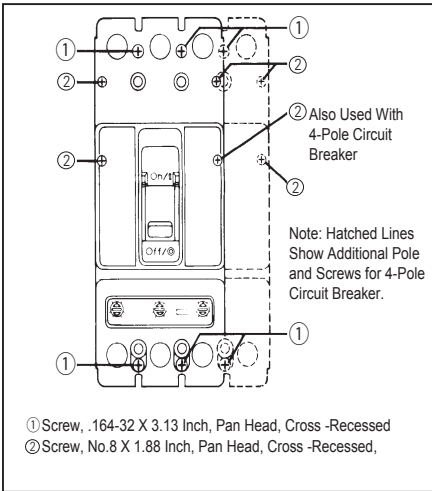

Fig. 2-4 Cover Screw Installation Positions

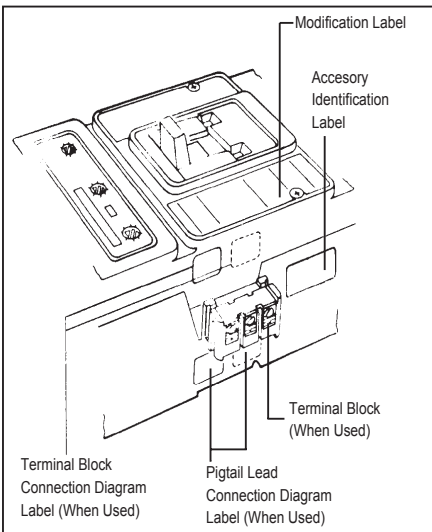

Fig. 2-5. Preferred Mounting Locations for Accessory Nameplate Labels

RETENTION.

2-6. With circuit breaker handle in OFF position and accessory pigtail leads (if used) routed as required, install circuit breaker cover. Secure with pan-head screws followed by

thread forming screws, as shown in Fig. 2-4.

2-7. Remove and discard UL listing label on JDB circuit breakers only.

2-8. Place accessory labels (supplied with kit) on circuit breaker. (See Fig. 2-5).

NOTICE

Accessory labels show connection diagram for auxiliary switch. Pigtail leads are color coded red, black, and blue.

2-9. Test auxiliary switch(es). Connect continuity tester or ohmmeter across pigtail leads or terminal block connections. Check continuity as follows:

a. Circuit breaker handle OFF
 "a" contact(s) - open
 "b" contact(s) - closed.

b. Circuit breaker handle ON
 "a" contact(s)- closed
 "b" contact(s)- open.

c. Press PUSH-TO-TRIP button
 "a" contact(s)- open
 "b" contact(s) - closed.

d. If auxiliary switch(es) fails test, make sure that auxiliary switch(es) module is properly seated in trip unit slots. If auxiliary switch(es) appears to be correctly installed and the problem persists, contact Eaton.

2-10. Install circuit breaker.

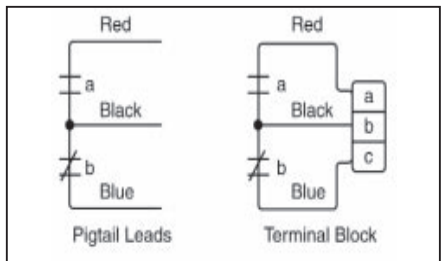

Fig. 2-6. Auxiliary Switch Connection Diagram

2-11. Connect auxiliary switch as required. (See Fig. 2-6). Eaton assumes no responsibility for malfunctioning accessories installed by the customer.

Eaton Electrical, Inc.
1000 Cherrington parkway
Moon Township, PA 15108-4312
USA
Tel: 1-800-525-2000
www.EatonElectrical.com

©2015 Eaton corporation
All Rights Reserved
Style 6631C64H02
Printed in Dominican Republic
Effective September 2015

