



## Installation Instructions for DIN RAIL KIT GC/GHC 3 POLE CIRCUIT BREAKERS



### WARNING

**DO NOT ATTEMPT TO INSTALL OR PERFORM MAINTENANCE ON EQUIPMENT WHILE IT IS ENERGIZED. DEATH, SEVERE PERSONAL INJURY, OR SUBSTANTIAL PROPERTY DAMAGE CAN RESULT FROM CONTACT WITH ENERGIZED EQUIPMENT. ALWAYS VERIFY THAT NO VOLTAGE IS PRESENT BEFORE PROCEEDING WITH THE TASK, AND ALWAYS FOLLOW GENERALLY ACCEPTED SAFETY PROCEDURES.**

**CUTLER-HAMMER IS NOT LIABLE FOR THE MISAPPLICATION OR MISINSTALLATION OF ITS PRODUCTS.**

### TO INSTALL:

- 1 Assemble mounting clip as shown in **fig. 1**.
- 2 Using mounting screws, attach mounting clip to back of breaker as shown in **fig. 2**.

### TO MOUNT TO DIN RAIL:

- 1 Position breaker with mounting clip to din rail as shown in **fig. 3**.
- 2 Using a screw driver, position blade to slot in mounting clip extension and pry down to allow clip to open as shown in **fig. 4**.

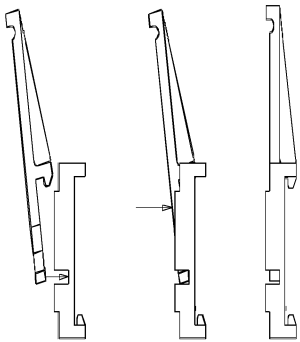

(1)

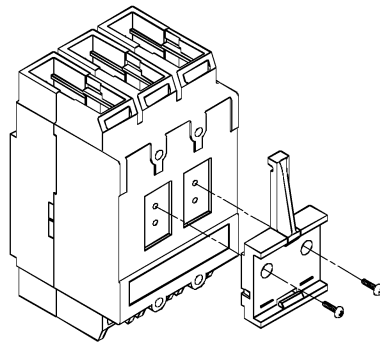

(2)

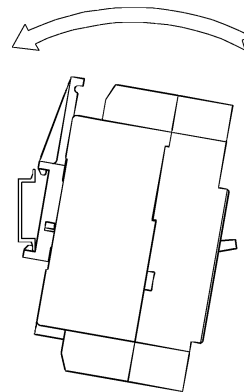

(3)

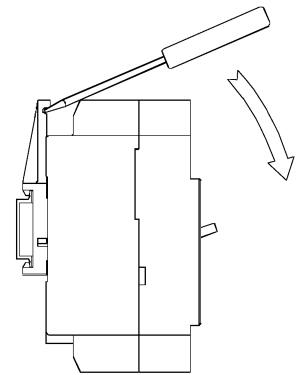

(4)