

Installation Instructions for the Walking Beam Interlock for Eaton EHD, FDB, FD, HFD, FDC, FW, HFW, FWC, Circuit Breakers and Molded Case Switches

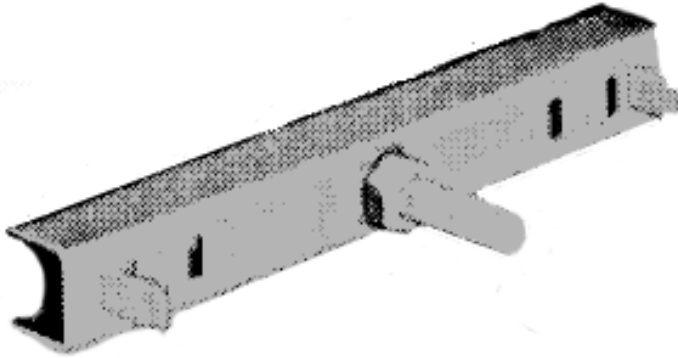

Contents

| Description | Page |
|--------------------|------|
| Introduction | 2 |
| Installation | 3 |



Powering Business Worldwide



WARNING

DO NOT ATTEMPT TO INSTALL OR PERFORM MAINTENANCE ON EQUIPMENT WHILE IT IS ENERGIZED. DEATH, SEVERE PERSONAL INJURY, OR SUBSTANTIAL PROPERTY DAMAGE CAN RESULT FROM CONTACT WITH ENERGIZED EQUIPMENT. ALWAYS VERIFY THAT NO VOLTAGE IS PRESENT BEFORE PROCEEDING WITH THE TASK, AND ALWAYS FOLLOW GENERALLY ACCEPTED SAFETY PROCEDURES.

EATON IS NOT LIABLE FOR THE MISAPPLICATION OR MISINSTALLATION OF ITS PRODUCTS.

The user is cautioned to observe all recommendations, warnings, and cautions relating to the safety of personnel and equipment, as well as, all general and local health and safety laws, codes, and procedures.

The recommendations and information contained herein are based on Eaton experience and judgement, but should not be considered to be all-inclusive or covering every application or circumstance which may arise. If any questions arise, contact Eaton for further information or instructions.

1. INTRODUCTION

General Information

The walking beam interlock (Fig. 1-1) provides mechanical interlocking between two adjacent circuit breakers of the same pole configuration to prevent both circuit breakers from being switched on at the same time. The circuit breakers are secured to a customer-supplied mounting panel, which may be up to one inch thick. The walking beam interlock mounting bracket is then bolted to the rear of the panel using circuit breaker mounting hardware. A special backplate, modified to accept a plunger, has been factory-installed on each circuit breaker. A plunger on each end of the walking beam is inserted through an access hole in the backplate and base of each circuit breaker.

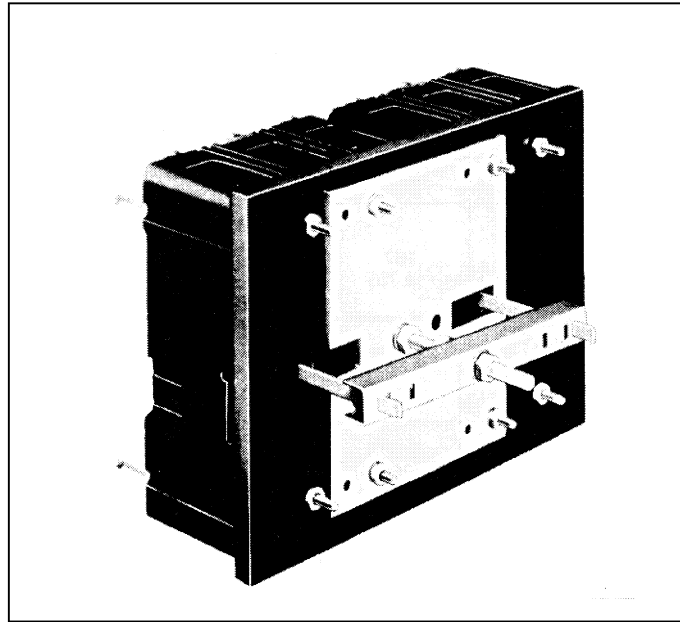

Fig. 1-1. Walking Beam Interlock Installed Between Two 3-Pole F-Frame Series C Circuit Breakers

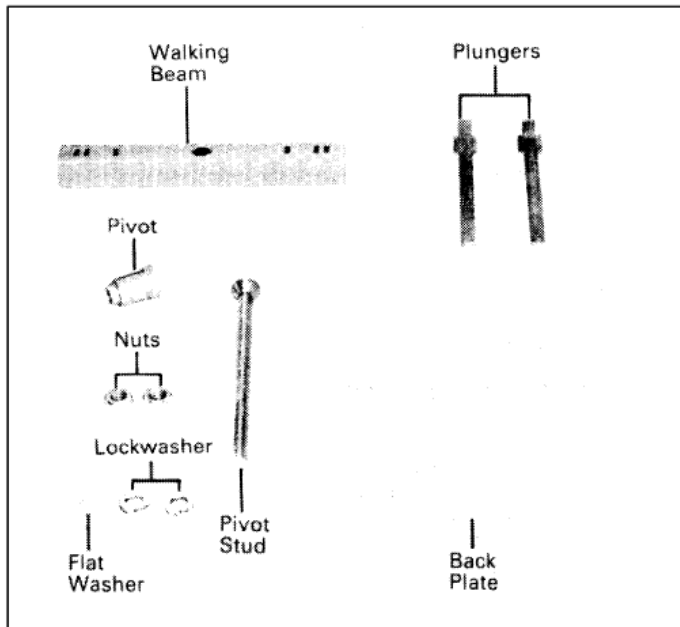

Fig. 1-2. Walking Beam Interlock Kit for F-Frame Series C Circuit Breakers

When the walking beam interlock is used, the wiring troughs in the back of each circuit breaker case are blocked by the plungers and cannot be used for opposite side-exiting pigtail leads. The walking beam interlock is UL listed for field installation per UL File E64983.

Note: Factory modified circuit breakers must be ordered to install the walking beam interlock.

This instruction leaflet (IL) gives detailed procedures for installing the walking beam interlock. The walking beam interlock in kit form is shown in Fig. 1-2.

2. INSTALLATION

The walking beam interlock must be mounted before the circuit breakers are connected to an electrical system. Installation consists of drilling mounting panel to correspond with the walking beam backplate spacing requirements; securing backplate and circuit breakers to mounting surface; and, installing and adjusting walking beam. To install the walking beam interlock, perform the following steps:



WARNING

BEFORE ATTEMPTING ANY WORK ON CIRCUIT BREAKERS INSTALLED IN AN ELECTRICAL SYSTEM, MAKE SURE THE CIRCUIT BREAKERS ARE SWITCHED TO THE OFF POSITION AND THAT THERE IS NO VOLTAGE PRESENT WHERE WORK IS TO BE PERFORMED. SPECIAL ATTENTION SHOULD BE PAID TO REVERSE FEED APPLICATIONS TO ENSURE NO VOLTAGE IS PRESENT. THE VOLTAGES IN ENERGIZED EQUIPMENT CAN CAUSE SEVERE PERSONAL INJURY OR DEATH.

- 2-1. Pre-drill circuit breaker mounting panel. Figs. 2-1 (2-pole), 2-2 (3-pole), and 2-3 (4-pole) show mounting panel hole sizes and dimensions for F-frame Series C circuit breaker configurations. Dimensions are in inches and (millimeters).

Note: Circuit breakers and walking beam backplate are secured to mounting panel by hardware optionally supplied with circuit breaker.

- 2-2. Select pivot stud mounting hole in walking beam backplate. (See Fig. 2-4.) Put stud in hole and secure it with nut and lockwasher.
- 2-3. Install circuit breakers on mounting panel using the two outer mounting holes in each circuit breaker.

Note: For 2-pole circuit breakers, the single set of mounting holes is used for both circuit breaker and backplate mounting.

- 2-4. Hold walking beam backplate on mounting panel behind circuit breakers. (See Fig. 2-4 for correct mounting holes.) Secure backplate to mounting panel using the two inner mounting holes in each circuit breaker.

Note: On 2-pole circuit breakers, all breaker mounting screws are also used to mount walking beam backplate.

- 2-5. Screw walking beam pivot onto pivot stud until pivot rests against nut. (See Fig. 2-5.)
- 2-6. Slide both plungers through walking beam backplate and mounting panel into circuit breakers. (See Fig. 2-5.)
- 2-7. Position walking beam on pivot stud making sure that plungers enter correct holes in walking beam. (See Fig. 2-6.)
- 2-8. With one circuit breaker in the ON position and the other in the OFF position, place flat washer and lockwasher on pivot stud. Screw nut onto pivot stud until walking beam is held by nut (Fig 2-7).
- 2-9. Screw walking beam pivot along stud until shoulder on pivot enters recess in walking beam (Fig. 2-7). Tighten pivot against washers and nut.
- 2-10. Carry out a functional check.
- Make sure that both circuit breakers cannot be switched to the ON position at the same time.
 - Open one circuit breaker. Be sure the other will close.
 - Reverse the open and close operation.
- 2-11. Connect circuit breakers as required.

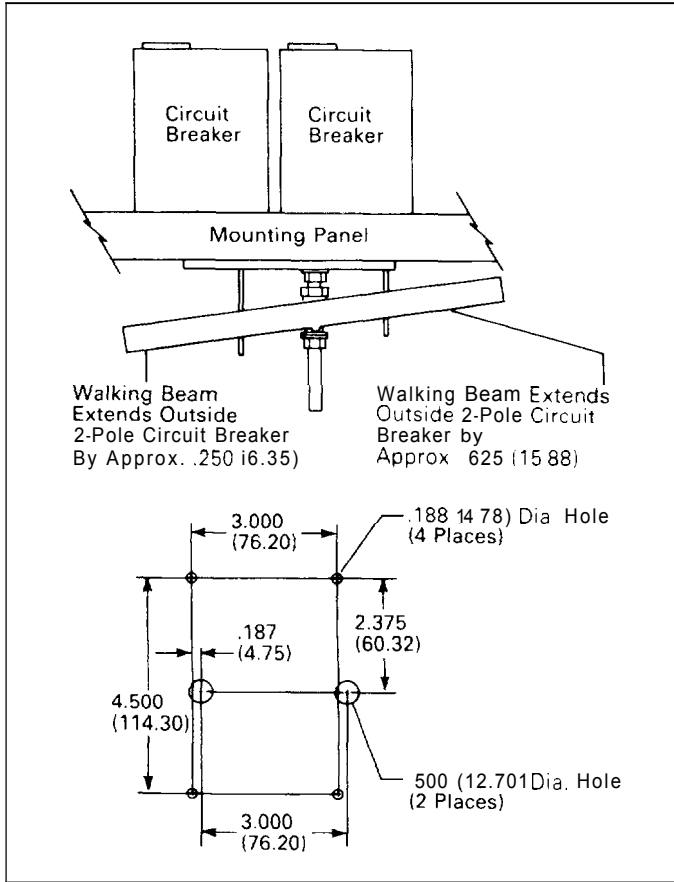

Fig. 2-1. 2-Pole Circuit Breaker Walking Beam Overlap, Mounting Panel Hole Sizes, and Dimensions

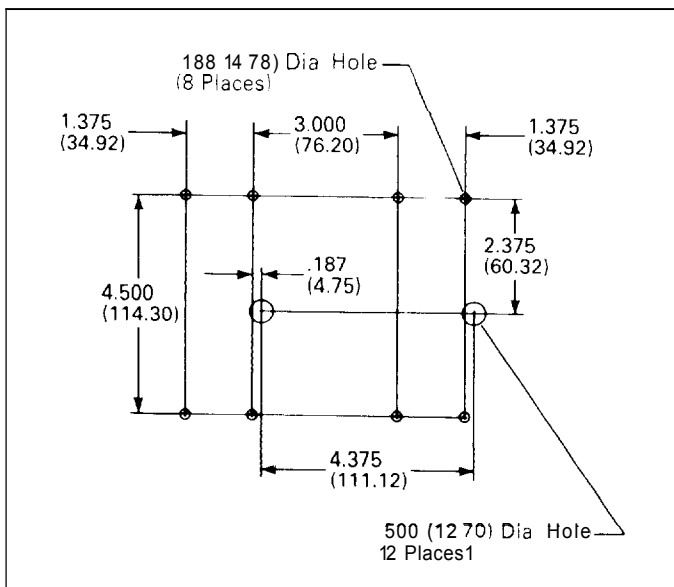

Fig. 2-2. 3-Pole Circuit Breaker Mounting Panel Hole Sizes and Dimensions

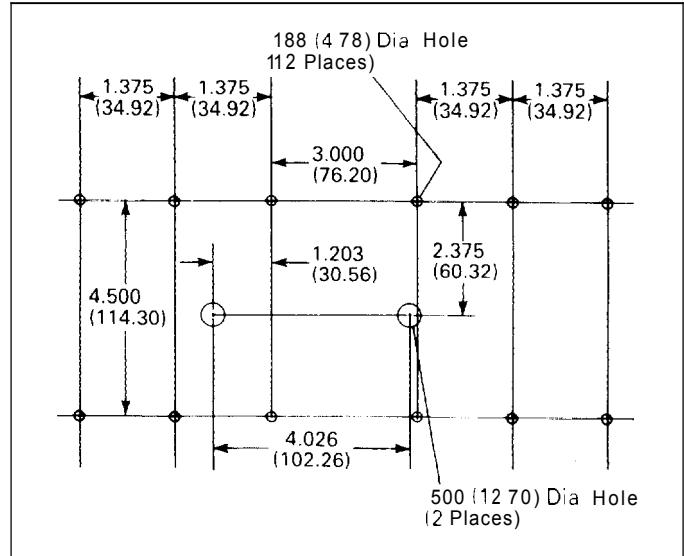

Fig. 2-3. 4-Pole Circuit Breaker Mounting Panel Hole Sizes and Dimensions

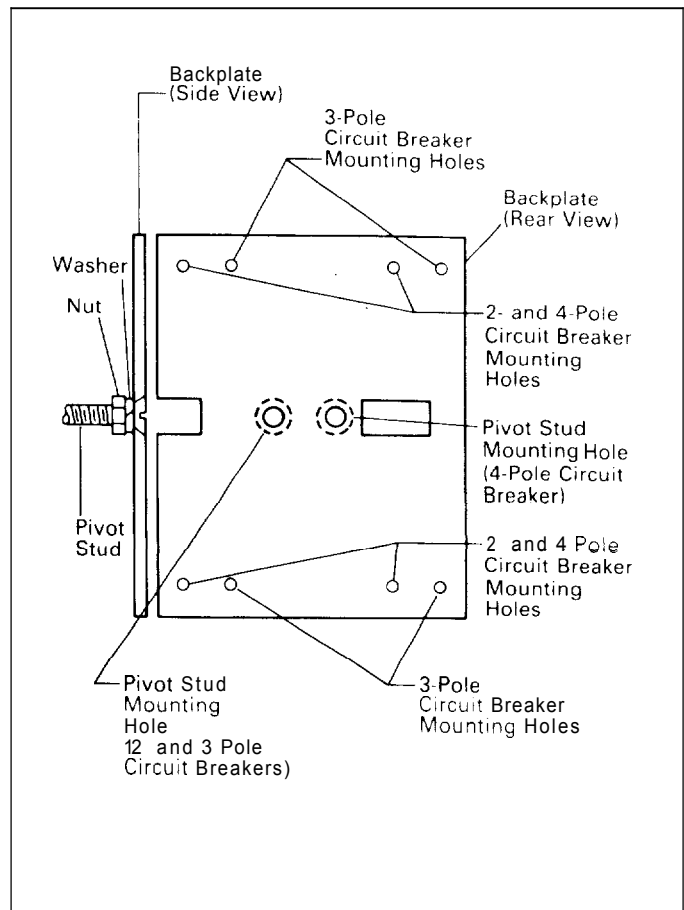

Fig. 2-4. Pivot Stud and Backplate Mounting Holes

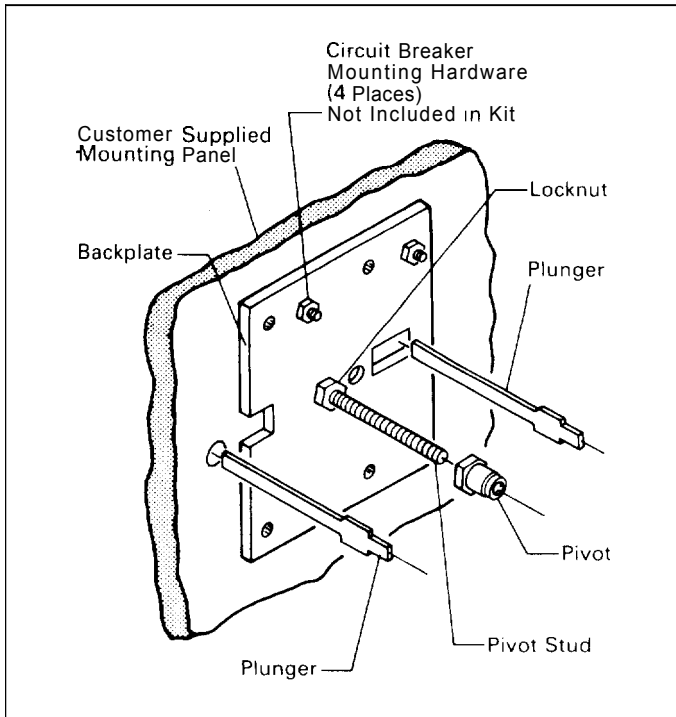

Fig. 2-5. Plungers Positioned through Backplate into 3-Pole Circuit Breakers

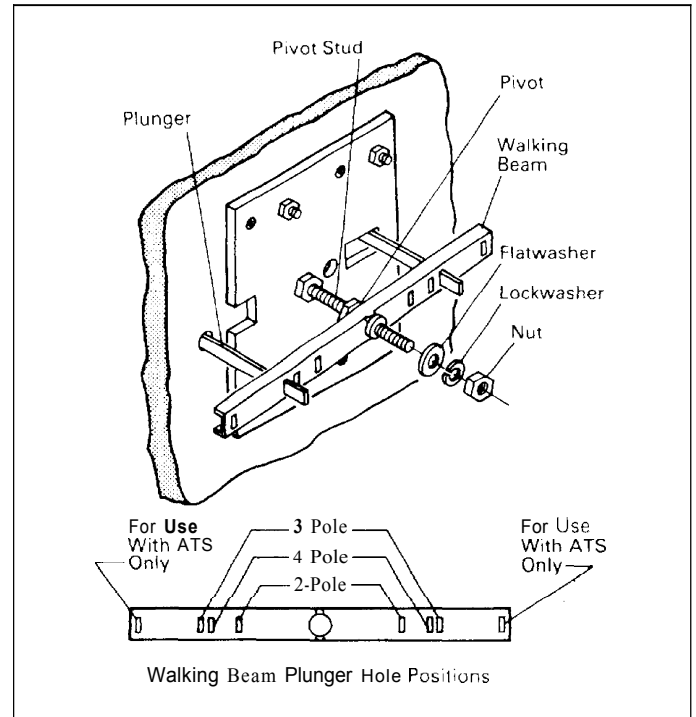

Fig. 2-6. Walking Beam in Position on Pivot Stud

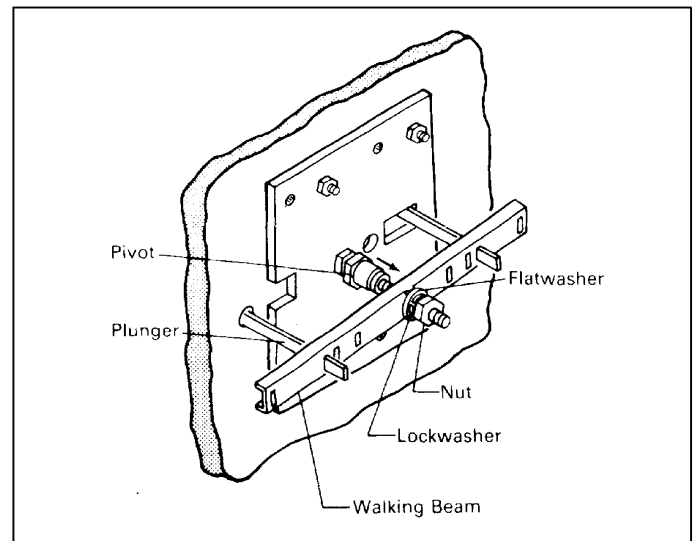

Fig. 2-7. Walking Beam Final Assembly

NOTES:

NOTES:

Instruction Leaflet IL 29C300C

Effective March 2014

Installation Instructions for the Walking Beam Interlock for Eaton EHD, FDB, FD, HFD, FDC, FW, HFW, FWC, Circuit Breakers and Molded Case Switches

The instructions for installation, testing, maintenance, or repair herein are provided for the use of the product in general commercial applications and may not be appropriate for use in nuclear applications. Additional instructions may be available upon specific request to replace, amend, or supplement these instructions to qualify them for use with the product in safety-related applications in a nuclear facility.

The information, recommendations, descriptions, and safety notations in this document are based on Eaton's experience and judgment with respect to Retrofitting of Power Breakers. This instructional literature is published solely for information purposes and should not be considered all-inclusive. If further information is required, you should consult an authorized Eaton sales representative.

The sale of the product shown in this literature is subject to the terms and conditions outlined in appropriate Eaton selling policies or other contractual agreement between the parties. This literature is not intended to and does not enlarge or add to any such contract. The sole source governing the rights and remedies of any purchaser of this equipment is the contract between the purchaser and Eaton.

NO WARRANTIES, EXPRESSED OR IMPLIED, INCLUDING WARRANTIES OF FITNESS FOR A PARTICULAR PURPOSE OR MERCHANTABILITY, OR WARRANTIES ARISING FROM COURSE OF DEALING OR USAGE OF TRADE, ARE MADE REGARDING THE INFORMATION, RECOMMENDATIONS, AND DESCRIPTIONS CONTAINED HEREIN.

In no event will Eaton be responsible to the purchaser or user in contract, in tort (including negligence), strict liability or otherwise for any special, indirect, incidental or consequential damage or loss whatsoever, including but not limited to damage or loss of use of equipment, plant or power system, cost of capital, loss of power, additional expenses in the use of existing power facilities, or claims against the purchaser or user by its customers resulting from the use of the information, recommendations and description contained herein.

Eaton
Electrical Sector
1000 Eaton Boulevard
Cleveland, OH 44122
United States
877-ETN-CARE (877-386-2273)
Eaton.com

© 2014 Eaton
All Rights Reserved
Printed in USA
Publication No. IL 29C300C / TBG000493
Part No. 6620C55H04
March 2014



Eaton is a registered trademark.

All other trademarks are property of their respective owners.