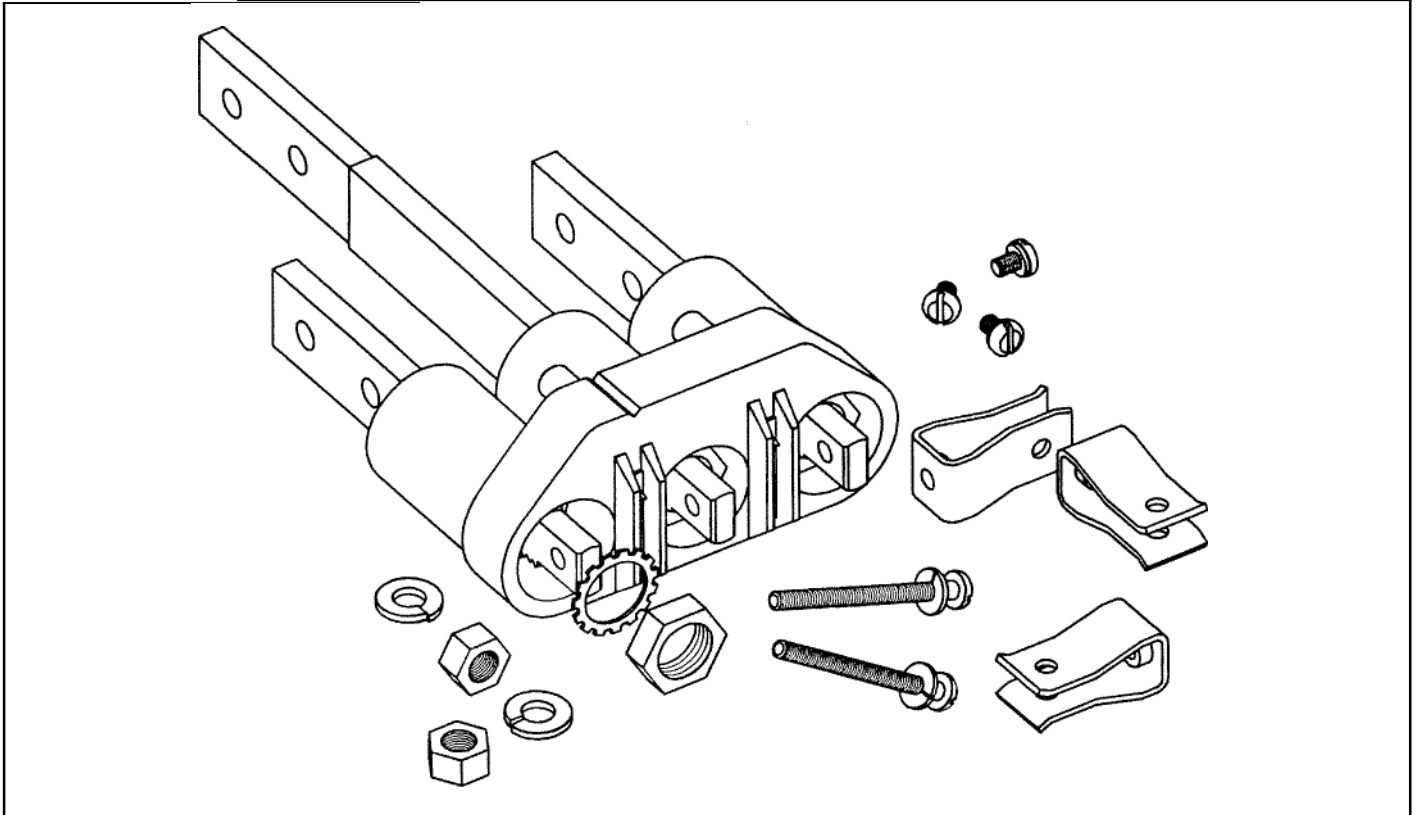


**Instructions for Plug-in Support Block Assembly for Cutler-Hammer  
EB, EHB, FB, HFB, FB TRI-PAC, FB and HFB Magnetic, MCP, HMCP, EHD,  
ED, EDH, EDC, FW, HFW, FWC, FDB, FD, HFD, and FDC Circuit Breakers**



**Fig.1 Support Block Assembly**

Figure 1 shows the Plug-in Adapter for the F family of breakers and its associated mounting hardware. The support block is assembled at the factory with the busbars in the vertical position, as shown. If the busbars are to be maintained in this position, proceed to the section titled "Installation of Support Block." If the busbars are to be positioned horizontally, follow the steps outlined in the next section.

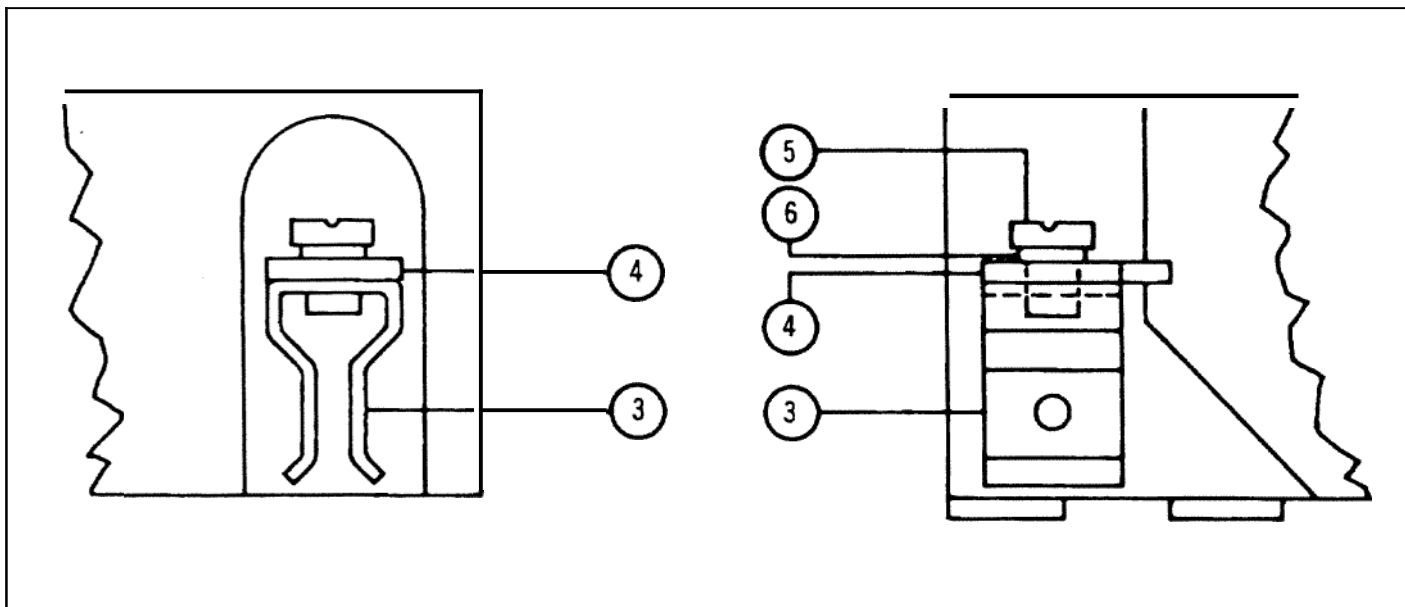
**HORIZONTAL CONFIGURATION OF BUSBAR**

The conductor bars may alternately be positioned horizontally, such that the mounting holes are facing upward. This may be accomplished as follows:

1. Loosen and remove the locking nuts inside of the molded support block. There is one lock nut for each phase. A thin-walled, 3/4 in. hex socket with 1 in. outside diameter is required.

The outside diameter of the socket may not be greater than 1.020 in. A thin-walled socket for a 3/8 drive is recommended. The following Hex sockets made by *Snap-On* can be used: F241 (12 point), FS241 (6 point), both for 3/8 in. drive.

2. Pull the busbars out of the molded support block, rotate them 90°, and re-insert them. (Be careful not to lose the lockwashers which are normally located between the molded support block and the locking nuts.) Upon insertion, the busbars should fit snugly within the molded support block.
3. Ensure that the lockwashers are re-inserted before the nuts are restarted. Carefully align the threads on the lock nuts with those on the copper conductors (improper alignment may result in stripping of threads). The lock nuts should be torqued to 6 - 8 ft-lbs (8.1 - 10.9 N-m). The lock nuts must not be over-torqued, as this action can damage the support block.



**Fig. 2 Plug-In Support Block**

**INSTALLATION OF SUPPORT BLOCK**

The support block assembly is designed exclusively for plug-in mounting. Although the support block can be attached to the breaker with screws, the busbars cannot be bolted to the stabs.

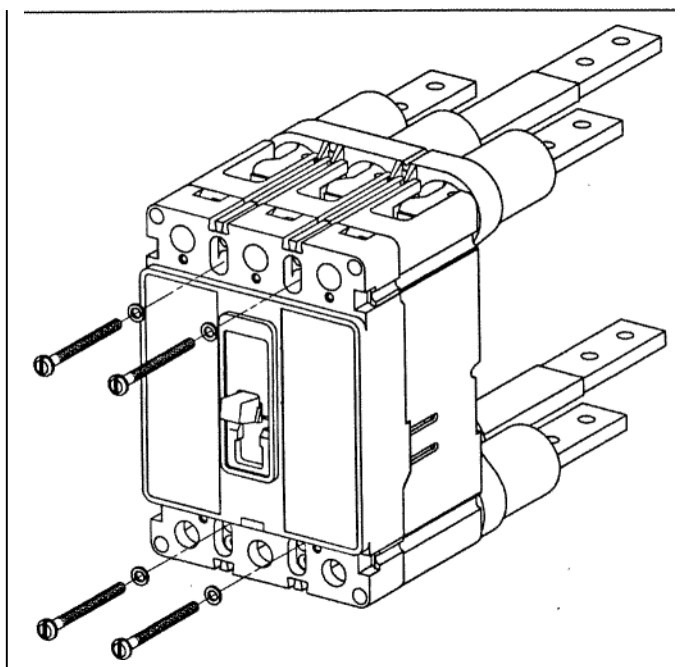
1. As shown in Figure 2, the stabs (3) must be attached to the circuit breaker. The stab should be positioned on the outside of the breaker conductor (4), facing outward from the back of the breaker.
2. Secure the stab to the conductor with the included .190-32 x 3/8 in. screw and washer. The screw must be tightened, but not fully, from the front of the circuit breaker.
3. Align the stabs with the busbars from the support block. To accomplish this, the support block should be held against the rear of the breaker in the exact position in which it must be mounted.
4. When the alignment is complete, the screws in the stabs must be tightened fully.

The support block can be attached to the breaker with the included screws and washers as shown in Figure 3. Two sets of mounting hardware are available, depending upon the style of support block assembly; one for the FD family of breakers, and another for the FB family of breakers.

For the FD family of breakers, which includes FD, HFD, FDC, EHD, ED, EDH, EDC, and HMCP breakers (Support Blocks 1480D13G01 and 1480D13G02), the .164-32 x 1 3/4 in. pan screws and lockwashers must be used.

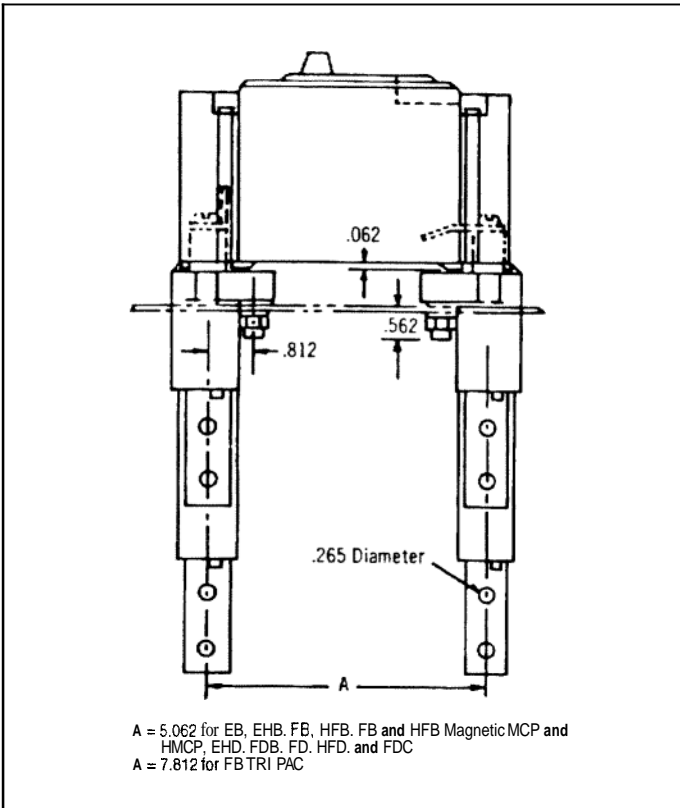
These screws must align with the mounting holes on the breaker and the two threaded inserts in the support block.

For the FB family of breakers (Support Blocks 1480D13G05 and 1480D13G06), the .164-32 x 3 1/2 in. pan screws with lockwashers must be used. These screws must align with the mounting holes on the breaker and the two threaded inserts in the support block.

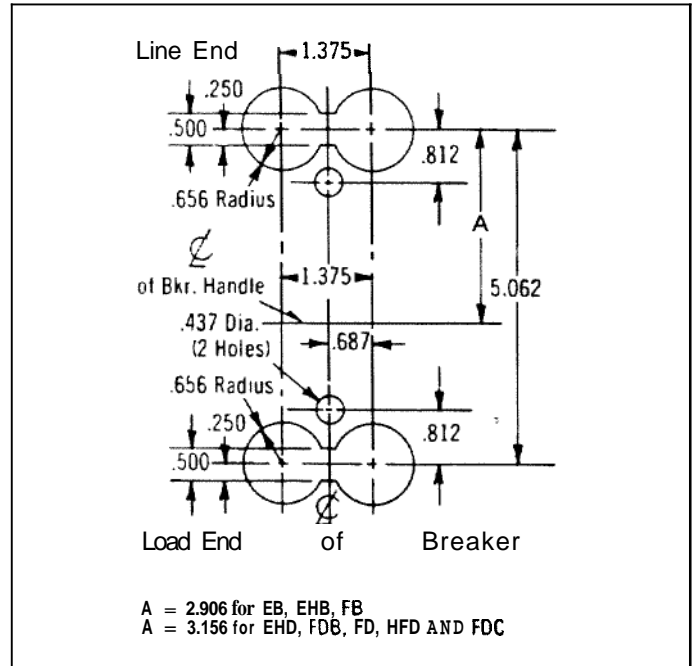


**Fig. 3 Attachment to Circuit Breaker**

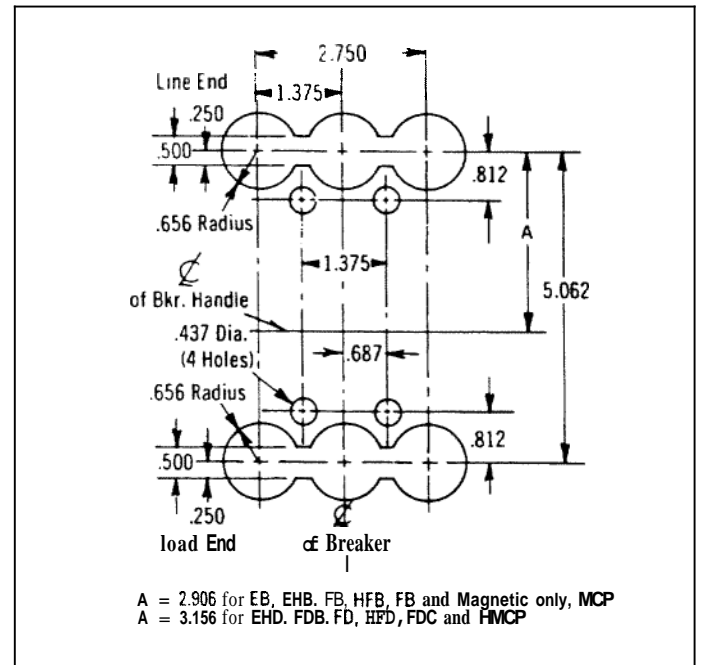
Refer to Figures 4 - 8 for the drilling pattern required to mount the plug-in adapter to a panel.



**Fig. 4 Support Block Assembled to Breaker**



**Fig. 5 Drilling plan 2 pole EB, EHB, FB, EHD, ED, EDH, EDC, FDB, FD, HFD, and FDC Thermal Magnetic Breakers**



**Fig. 6 Drilling Plan 2 Pole, FB and HFB Magnetic Only, HFB, MCP, and 3 Pole, EB, EHB, FB, HFB, FB and HFB Magnetic Only, MCP and HMCP, EHD, ED, EDH, EDC, FDB, FD, HFD, and FDC**

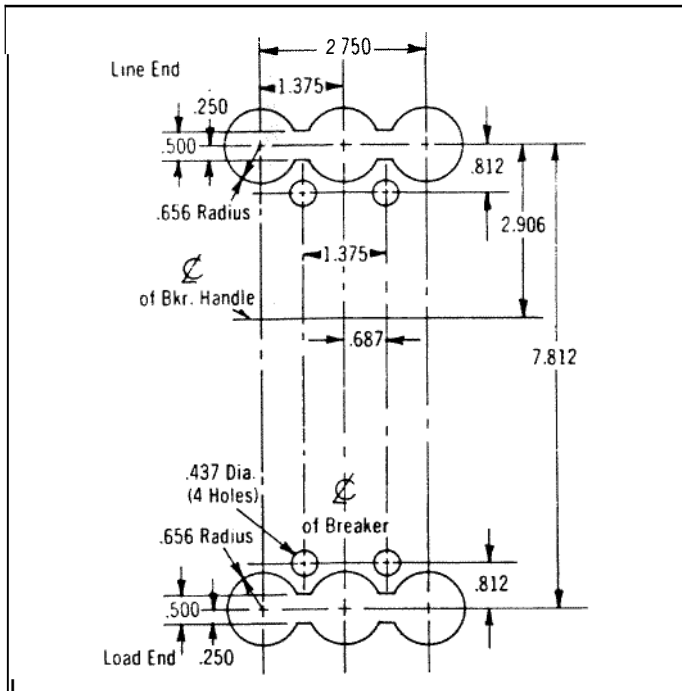


Fig. 7 Drilling Plan 2 and 3 Pole Tri-Pac FB

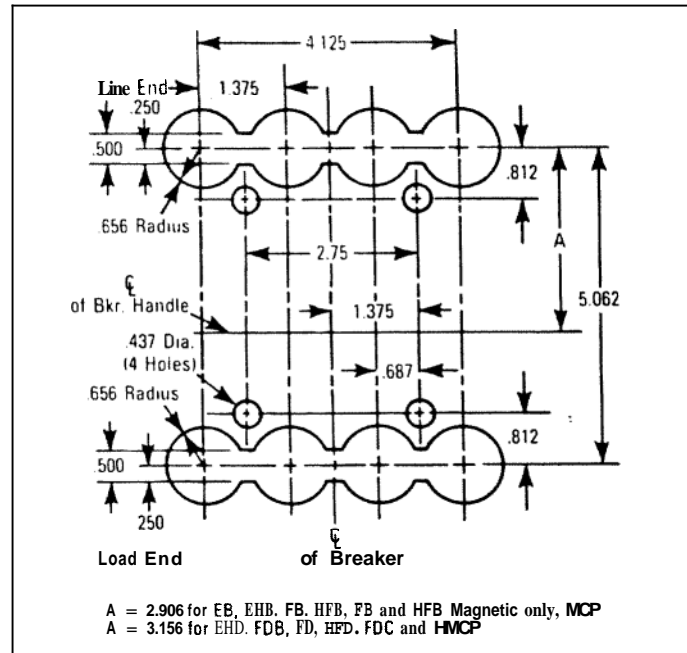


Fig. 8 Drilling Plan 4 Pole, EB, EHB, FB, HFB, FB and HFB Magnetic Only, MCP and HMCP, EHD, FDB, FD, HFD, and FDC

Eaton Corporation  
 Cutler-Hammer business unit  
 1000 Cherrington Parkway  
 Moon Township, PA 15108-4312  
 USA  
 tel: 1-800-525-2000  
 www.cutler-hammer.com

© 2001 Eaton Corporation  
 All Rights Reserved  
 Printed USA/TQC  
 Publication No. 6620C61H06  
 Effective 6/2003