



**Westinghouse  
Series C  
AB De-Ion  
Circuit Breaker  
Accessory**

**For Types:**

**EHD FDB  
FD HFD FDC  
FW HFW FWC**

Westinghouse Electric Corp.  
Electrical Components Div.  
Pittsburgh, Pa. 15220

Printed in U.S.A.  
4209 B54 H01

### Control Wire Terminal Kit

**Style No. 5090A92G01  
Quantity - 12**

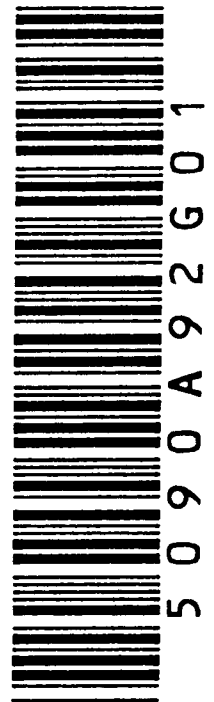
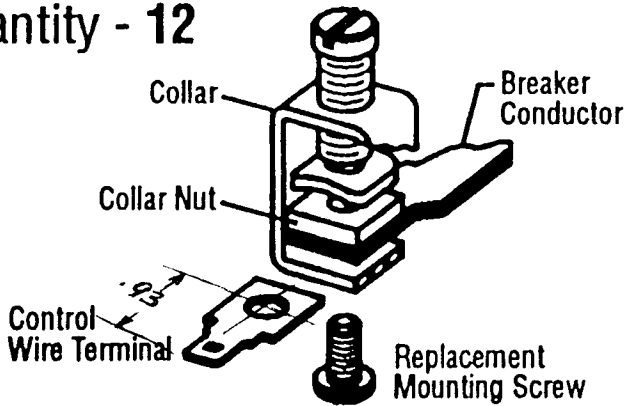

Package of 12 Control Wire Terminals & 12 Screws  
Use Only With Steel Collars.

**Instructions For Assembly -**

- Remove 5/16 Long Collar Mounting Screw
- Insert Terminal Between Bottom of Conductor & Collar
- Insert 3/8 Long Replacement Screw Through Collar, Terminal & Conductor & Tighten Into Nut

**Do Not Remove Control Wire Terminal Without Reinstalling 5/16 Long Screw or Cable May Loosen & Overheat.**

*CATA FCWTK*