



Instructions for F-Frame 300 MCM Terminal Kit, Catalog No. 3TA225FDK. For Use on Series C F-Frame Circuit Breakers, Molded Case Switches and Motor Circuit Protectors.

KIT CONTENTS

Package of 3 terminals, 3 washers, 3 terminal Mounting Screws, 1 Terminal Shield, 3 Terminal Shield Mounting Screws, and 1 Warning/Torque Label.

Wire Range 6 to 300 MCM Cu-Al
Metric Wire Range 16 mm² to 150 mm² Cu-Al

INSTRUCTIONS FOR ASSEMBLY

- If circuit breaker is installed in equipment, it must be removed from the equipment to install this kit.
- Assemble collar on top of conductor as shown and tighten securely with button head socket screw (.25-20 x 3/8" long) and washer to 100 in-lbs.
- Slide the terminal shield into position on the end of the circuit breaker.
- Use the (6-19 x 3/8" long) high-low screws provided to secure the shield in place. The line end uses 3 screws and the load end uses 2 screws.
- Apply 300 MCM terminal kit label to top of breaker.



CAUTION

HAZARDOUS VOLTAGE - TERMINAL SHIELD MUST BE INSTALLED WHEN USING THE EXTENDED LUG. TERMINAL MUST BE MOUNTED ON TOP OF CONDUCTOR AND SCREW HEAD UNDERNEATH THE CONDUCTOR TO MAINTAIN ELECTRICAL CLEARANCES.

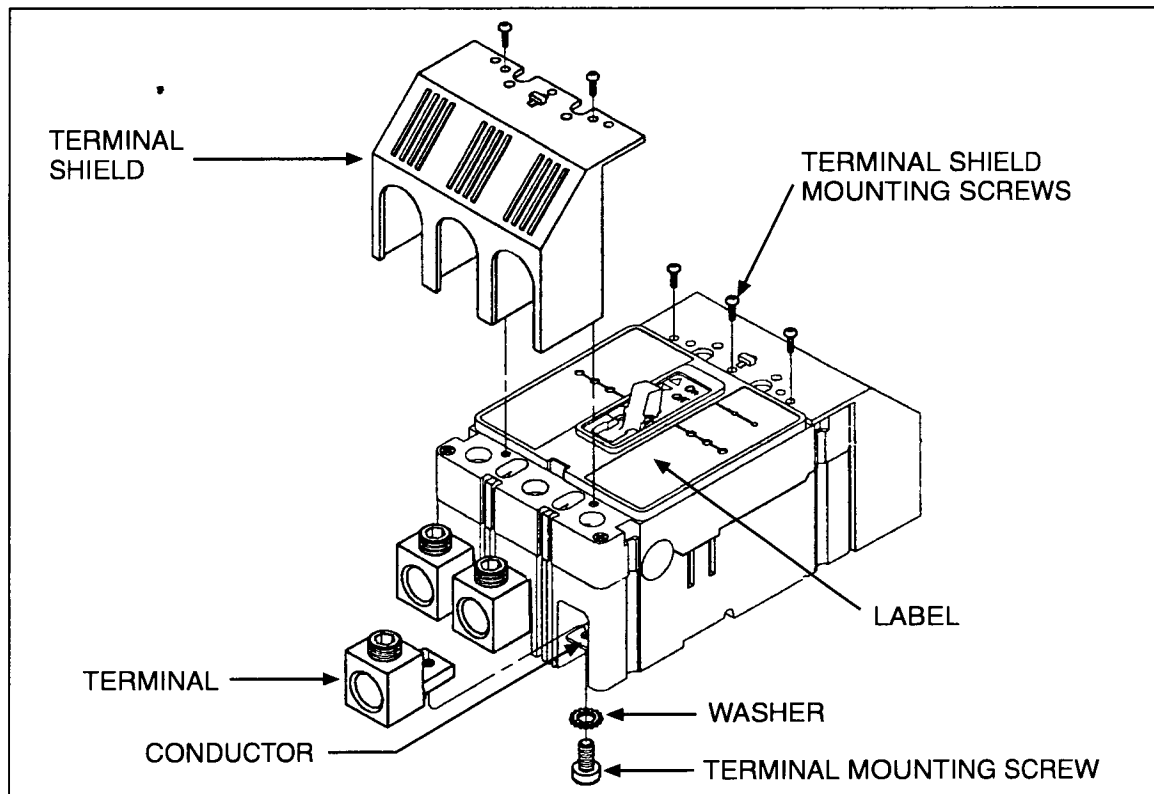

Cutler-Hammer

Pittsburgh, Pennsylvania, U.S.A.