

**EAT•N**

Cutler-Hammer

Circuit Breaker  
Accessory

For F-Frame

Cutler-Hammer Business  
Pittsburgh, PA.

4206 B07 H12

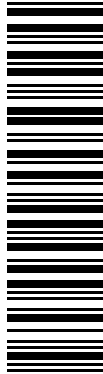
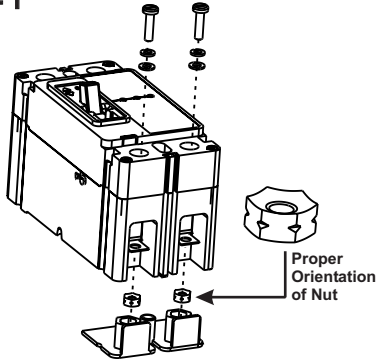
**2-POLE F-FRAME END CAP KIT - METRIC**Cat. No. - KPEKM12  
Style No. - 6606C63G02  
Quantity - 1

1 07 82114 29182 2

INSTALL END CAP PRIOR TO BREAKER INSTALLATION.

Instructions For Assembly:

Insert Nuts into End Cap with Flat Surface of Nut Toward  
Plastic End Cap.Place End Cap on Breaker, May be Applied to Line or Load  
End.

Install Breaker.

Fasten Conductors (Install Bolted Connections).

Torque Terminal Screws to 34-38 lb-in (4.0-4.4 N-m).

**EAT•N**

Cutler-Hammer

Circuit Breaker  
Accessory

For F-Frame

Cutler-Hammer Business  
Pittsburgh, PA.

4206 B07 H12

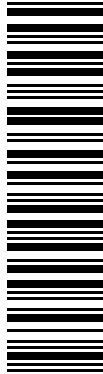
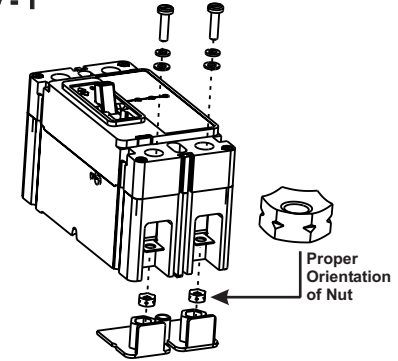
**2-POLE F-FRAME END CAP KIT - METRIC**Cat. No. - KPEKM12  
Style No. - 6606C63G02  
Quantity - 1

1 07 82114 29182 2

INSTALL END CAP PRIOR TO BREAKER INSTALLATION.

Instructions For Assembly:

Insert Nuts into End Cap with Flat Surface of Nut Toward  
Plastic End Cap.Place End Cap on Breaker, May be Applied to Line or Load  
End.

Install Breaker.

Fasten Conductors (Install Bolted Connections).

Torque Terminal Screws to 34-38 lb-in (4.0-4.4 N-m).

ECN # FD-10254 4206B07H12

**EAT•N**

Cutler-Hammer

Circuit Breaker  
Accessory

For F-Frame

Cutler-Hammer Business  
Pittsburgh, PA.

4206 B07 H12

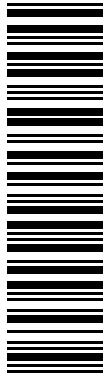
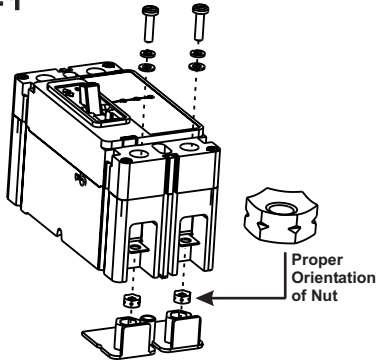
**2-POLE F-FRAME END CAP KIT - METRIC**Cat. No. - KPEKM12  
Style No. - 6606C63G02  
Quantity - 1

1 07 82114 29182 2

INSTALL END CAP PRIOR TO BREAKER INSTALLATION.

Instructions For Assembly:

Insert Nuts into End Cap with Flat Surface of Nut Toward  
Plastic End Cap.Place End Cap on Breaker, May be Applied to Line or Load  
End.

Install Breaker.

Fasten Conductors (Install Bolted Connections).

Torque Terminal Screws to 34-38 lb-in (4.0-4.4 N-m).

**EAT•N**

Cutler-Hammer

Circuit Breaker  
Accessory

For F-Frame

Cutler-Hammer Business  
Pittsburgh, PA.

4206 B07 H12

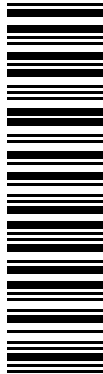
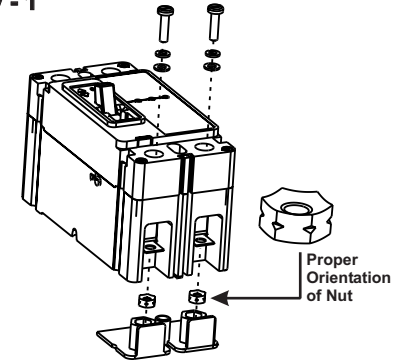
**2-POLE F-FRAME END CAP KIT - METRIC**Cat. No. - KPEKM12  
Style No. - 6606C63G02  
Quantity - 1

1 07 82114 29182 2

INSTALL END CAP PRIOR TO BREAKER INSTALLATION.

Instructions For Assembly:

Insert Nuts into End Cap with Flat Surface of Nut Toward  
Plastic End Cap.Place End Cap on Breaker, May be Applied to Line or Load  
End.

Install Breaker.

Fasten Conductors (Install Bolted Connections).

Torque Terminal Screws to 34-38 lb-in (4.0-4.4 N-m).