

Time current curves Power Defense MCCB Frame 3 thermal-magnetic and PXR electronic trip units Standards: UL, CSA, IEC, CCC

Contents

Description	Page
Table 1. Revision notes	3
Table 2. Circuit breaker catalog number convention.	4
Table 3. Electronic trip unit catalog number convention.	5
Table 4. Thermal magnetic trip unit catalog number convention	5
Table 5. Symmetrical RMS interruption ratings I_{cu} (kA) for each breaker frame.	6
Table 6. Curve notes.	6

Labels

Figure 1. Power Defense frame 3 trip unit front labels.	7
---	---

PXR electronic trip unit curves

Figure 2. PXR 20D / PXR 25 - I^2t long delay and flat short delay.	8
Figure 3. PXR 20 I^2t long delay and flat short delay.	9
Figure 4. PXR 20D / PXR 25 - I^2t long delay and I^2t short delay.	10
Figure 5. PXR 20 I^2t long delay and I^2t short delay.	11
Figure 6. PXR 20D / PXR 25 - I^4t long delay and flat short delay.	12
Figure 7. PXR 20D / PXR 25 ground (earth) flat delay.	13
Figure 8. PXR 20D / PXR 25 -ground (earth) I^2t delay.	14
Figure 9. PXR 20 - ground (earth) flat delay	15
Figure 10. PXR 20 - ground (earth) I^2t delay.	16
Figure 11. PXR 20D / PXR 25 - instantaneous and override for 125A frame.	17
Figure 12. PXR 20D / PXR 25 - instantaneous and override for 250A frame.	18
Figure 13. PXR 20D / PXR 25 - instantaneous and override for 400A frame.	19
Figure 14. PXR 20D / PXR 25 - instantaneous and override for H250A frame.	20
Figure 15. PXR 20D / PXR 25 - Instantaneous and override for H400A frame.	21
Figure 16. PXR 20D / PXR 25 - instantaneous and override for 600A frame.	22
Figure 17. PXR 20D / PXR 25 -instantaneous and override for 630A frame.	23
Figure 18. PXR 20 / PXR 10 - instantaneous and override for 125A frame.	24
Figure 19. PXR 20 / PXR 10 - instantaneous and override for 250A frame.	25
Figure 20. PXR 20 / PXR 10 - instantaneous and override for 400A frame.	26
Figure 21. PXR 20 / PXR 10 - instantaneous and override for H250A frame.	27



Powering Business Worldwide

Figure 22. PXR 20 / PXR 10 - instantaneous and override for H400A frame. 28
 Figure 23. PXR 20 / PXR 10 - instantaneous and override for 600A frame. 29
 Figure 24. PXR 20 / PXR 10 - instantaneous and override for 630A frame. 30
 Figure 25. PXR 20 / PXR 20D / PXR 25 - maintenance mode. 31
 Figure 26. PXR 10 LI 125A frame 32
 Figure 27. PXR 10 LI 250A frame. 33
 Figure 28. PXR 10 LI 400A frame 34
 Figure 29. PXR 10 LI H250A frame 35
 Figure 30. PXR 10 LI H400A frame 36
 Figure 31. PXR 10 LI 600A frame 37
 Figure 32. PXR 10 LI 630A frame 38
 Figure 33. PXR 10 LSI profile for short flat curves 39
 Figure 34. PXR 10 LSI profile for I²t short curves. 40

Thermal magnetic trip unit curves

Figure 35. 100A fixed thermal adjustable magnetic 41
 Figure 36. 125A fixed thermal adjustable magnetic 42
 Figure 37. 150A fixed thermal adjustable magnetic. 43
 Figure 38. 175A fixed thermal adjustable magnetic 44
 Figure 39. 200A fixed thermal adjustable magnetic 45
 Figure 40. 225A fixed thermal adjustable magnetic 46
 Figure 41. 250A fixed thermal adjustable magnetic 47
 Figure 42. 300A fixed thermal adjustable magnetic. 48
 Figure 43. 350A fixed thermal adjustable magnetic. 49
 Figure 44. 400A fixed thermal adjustable magnetic. 50
 Figure 45. 250A/320A/400A adjustable thermal adjustable magnetic. 51
 Figure 46. 250A/320A/400A adjustable thermal adjustable magnetic - current limiting. 52
 Figure 47. 250A – 600A fixed thermal adjustable magnetic. 53
 Figure 48. 500A/630A adjustable thermal adjustable magnetic. 54

Peak let through curves

Figure 49. Peak let through current 400A @ 240V. 55
 Figure 50. Peak let through energy 400A @ 240V. 56
 Figure 51. Peak let through current 400A @ 415V. 57
 Figure 52. Peak let through energy 400A @ 415V 58
 Figure 53. Peak let through current 400A @ 415V-480V. 59
 Figure 54. Peak let through energy 400A @ 415V-480V. 60
 Figure 55. Peak let through current 400A @ 600V. 61
 Figure 56. Peak let through energy 400A @ 600V 62
 Figure 57. Peak let through current 400A @ 690V. 63
 Figure 58. Peak let through energy 400A @ 690V. 64
 Figure 59. Peak let through current selective frames 600A @ 240V. 65
 Figure 60. Peak let through energy selective frames 600A @ 240V. 66
 Figure 61. Peak let through current selective frames 630A @ 240V. 67
 Figure 62. Peak let through energy selective frames 630A @ 240V. 68
 Figure 63. Peak let through current selective 600A @ 415V-480V 69
 Figure 64. Peak let through energy selective 600A @ 415V-480V 70
 Figure 65. Peak let through current selective 630A @ 415V-440V 71
 Figure 66. Peak let through energy selective 630A @ 415V-440V. 72
 Figure 67. Peak let through current selective 600A @ 600V. 73
 Figure 68. Peak let through energy selective 600A @ 600V. 74
 Figure 69. Peak let through current selective 630A @ 690V. 75
 Figure 70. Peak let through energy selective 630A @ 690V. 76

This information is provided only as an aid to understand the catalog numbers.
 It is not to be used to build catalog numbers for circuit breakers or trip units as all combinations may not be available.

Table 2. Circuit breaker catalog number convention

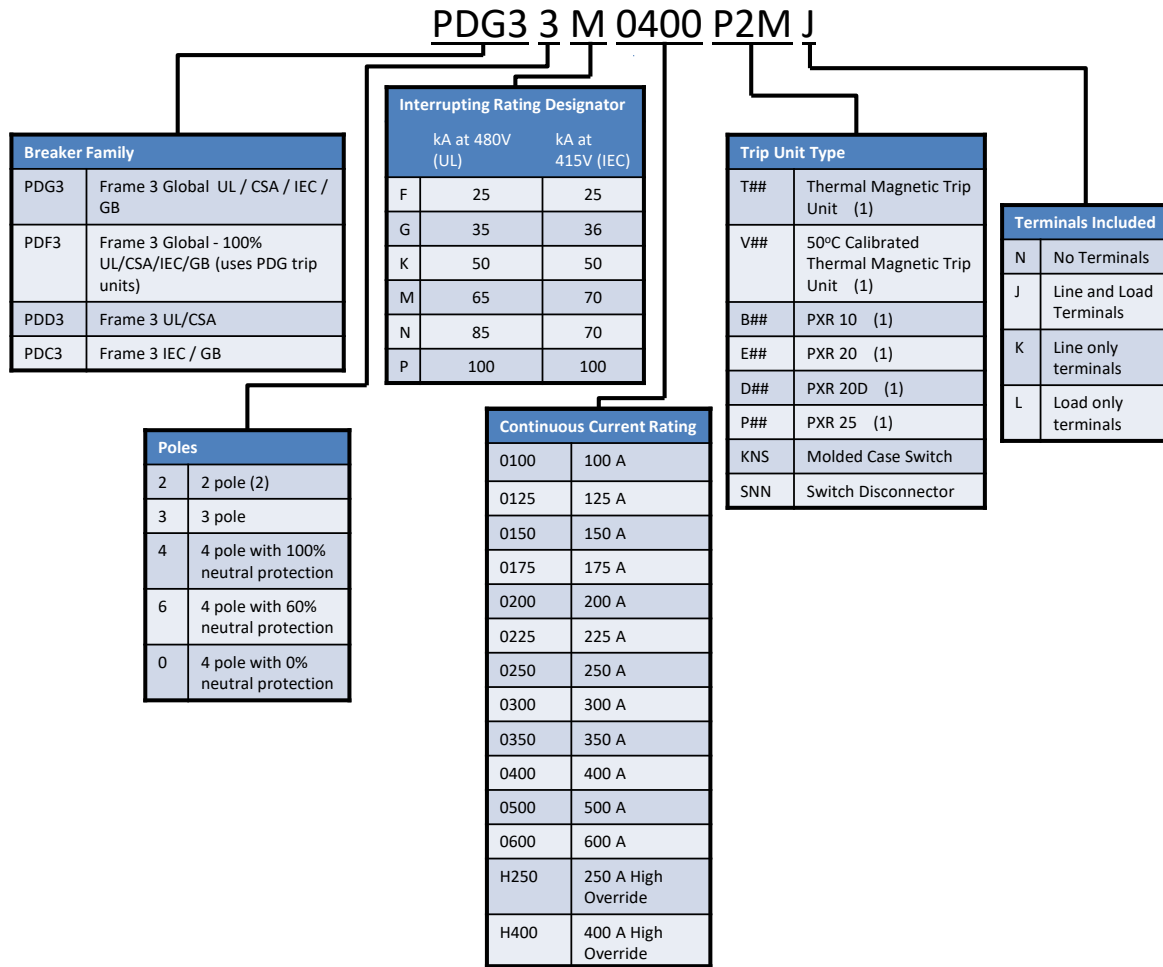

Note: 1 See catalog for ## (protection type and available configured options)

Note: 2 All PD-3 2-pole breakers are physically the same size as a 3-pole frame with the outer poles used for electrical connections.

Note: 3 IEC standard breakers include the CE mark; GB standard breakers include the CCC mark.

Table 3. Electronic trip unit catalog number convention

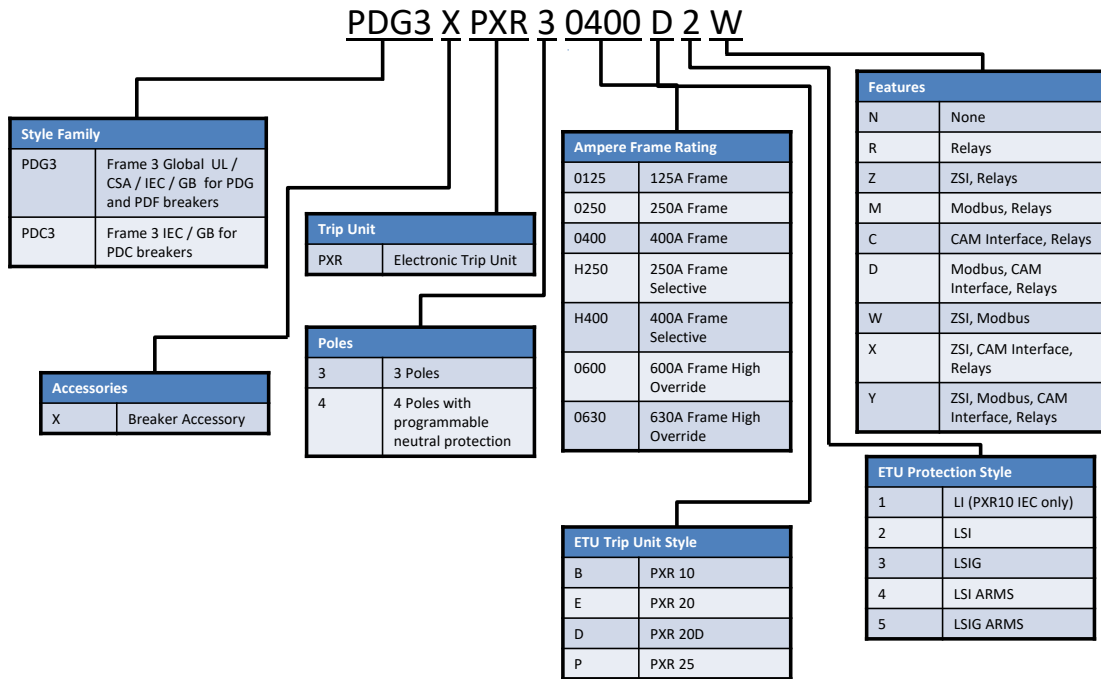

Note: IEC standard breakers include the CE mark; GB standard breakers include the CCC mark.

Note: The Selective frame styles have a higher override value for higher selective coordination capability.

Table 4. Thermal magnetic trip unit catalog number convention

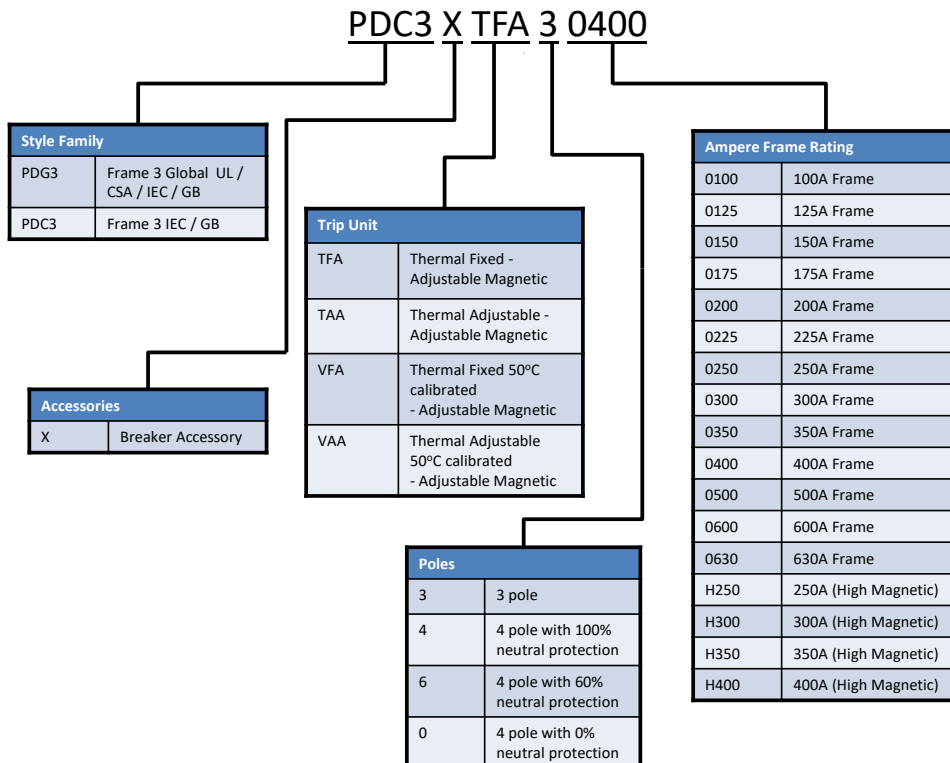

Note: IEC standard breakers include the CE mark; GB standard breakers include the CCC mark.

Table 5. Symmetrical RMS interruption ratings I_{cu} (kA) for each breaker frame

Voltage		UL / CSA			IEC / CCC						250 Vdc* 400A frame	250 Vdc* 600A/630A frame
		240V	480V	600V	240V	415V	440V	480V	525V	690V		
Frame												
Globally rated	PDG3xF	35	25	14	35	25	25	20	18	-	10	22
	PDG3xG	65	35	18	55	36	30	25	20	8	10	22
	PDG3xK	85	50	25	85	50	35	35	25	10	10	22
	PDG3xM	100	65	35	100	70	50	50	30	15	22	42
	PDG3xN	150	85	50	150	70	70	65	35	20	22	42
	PDG3xP	200	100	65	200	100	100	85	40	20	22	42
Globally rated (UL 100%)	PDF4xF	35	25	14	35	25	25	20	18	-	10	22
	PDF4xG	65	35	18	55	36	30	25	20	8	10	22
	PDF4xK	85	50	25	85	50	35	35	25	10	10	22
	PDF4xM	100	65	35	100	70	50	50	30	15	22	42
IEC / GB only	PDC3xF	-	-	-	35	25	25	20	18	-	10	22
	PDC3xG	-	-	-	55	36	30	25	20	8	10	22
	PDC3xK	-	-	-	85	50	35	35	25	10	10	22
	PDC3xM	-	-	-	100	70	50	50	30	15	22	42
	PDC3xN	-	-	-	150	70	70	65	35	20	22	42
UL/CSA Up to 240V	PDD3xF	35	-	-	-	-	-	-	-	-	10	22
	PDD3xG	65	-	-	-	-	-	-	-	-	10	22
	PDD3xK	85	-	-	-	-	-	-	-	-	10	22
	PDD3xM	100	-	-	-	-	-	-	-	-	22	42
	PDD3xN	150	-	-	-	-	-	-	-	-	22	42
	PDD3xP	200	-	-	-	-	-	-	-	-	22	42

* Two poles in series

Table 6. Curve notes

1. These curves apply for 50Hz and 60Hz applications
2. The maximum voltage rating for the frame style is stated in Table 5.
3. These curves are comprehensive for Power Defense style circuit breakers including frame sizes, ratings and constructions stated.
4. The total clearing times shown include the response time for the trip unit, the breaker opening and the interruption of the current. The bottom of the time band is the minimum commit to trip time.
5. The end of the curve is determined by the application or the interrupting rating of the circuit breaker.
6. Thermal Magnetic trip unit calibration based on 40°C ambient, cold start. Tested with 4 feet of rated wire (75°C) per terminal. Tested in open air with current in all poles.
7. Thermal Magnetic trip unit instantaneous calibration based on single pole testing.
8. All electronic trip units have an over temperature protection feature that will trip the breaker when the internal temperature of the ETU is over 105°C.
9. All time current data for PXR is based on 3 phase testing.

Labels

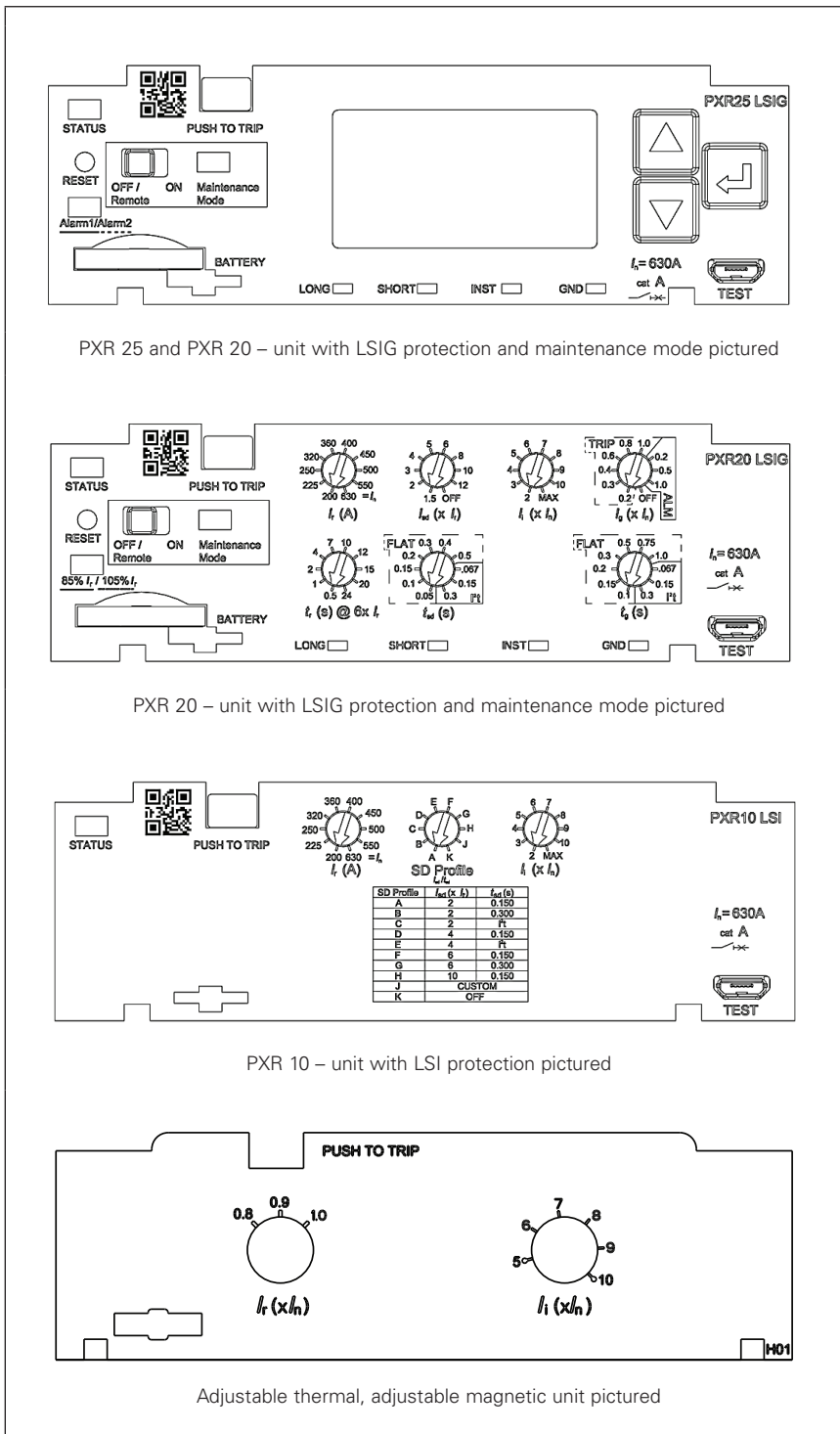

Figure 1. Power Defense frame 3 trip unit front labels.

Note: Trip unit drawings in Figure 1 are representative of the face plates provided. Values on the trip unit dials will change based upon the specific breaker and trip unit. Refer to the time current curve of the breaker or the PXR User Guide for the specific settings.

Curves

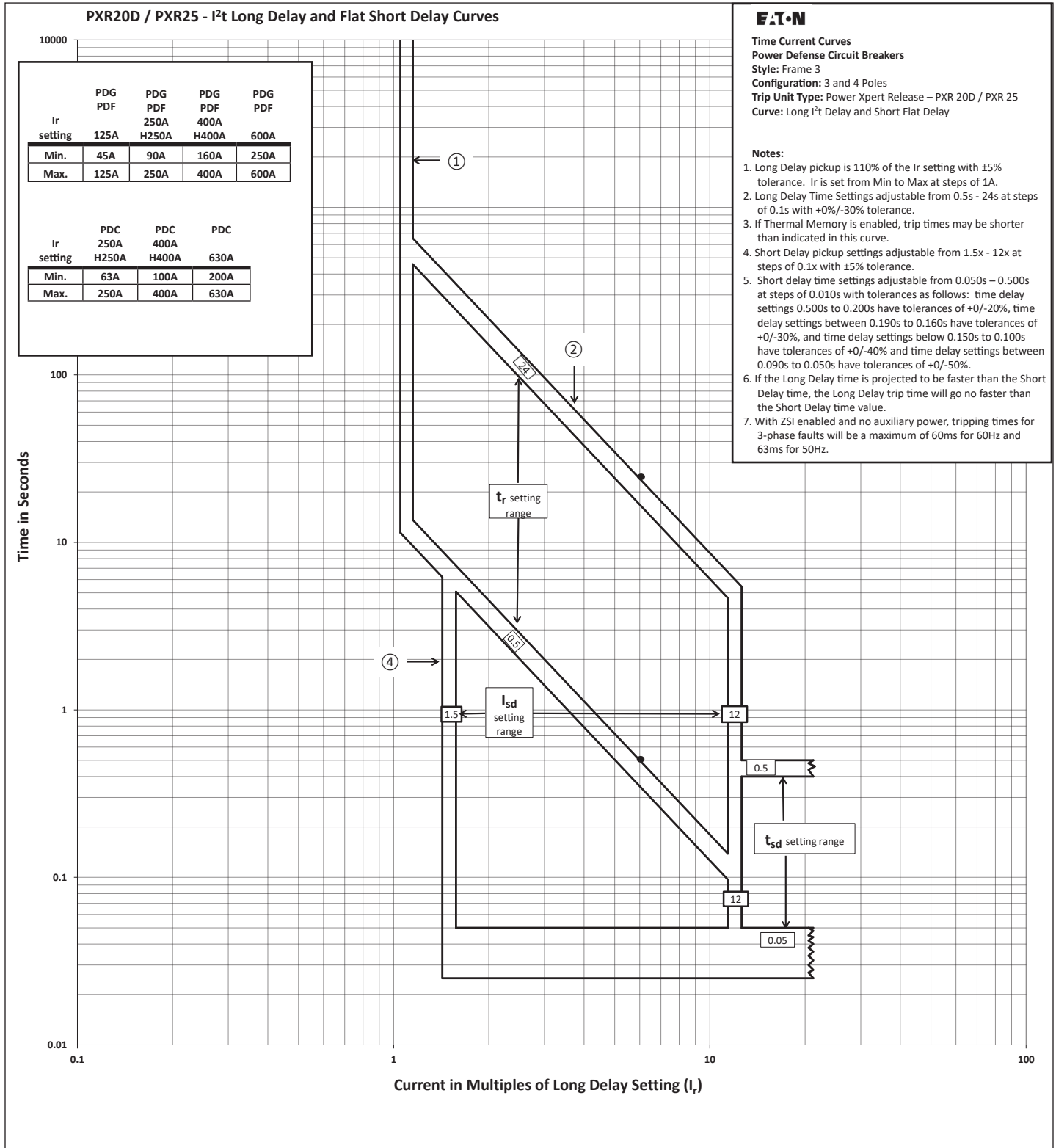

Figure 2. PXR 20D / PXR 25 - I²t long delay and flat short delay.

November 2019

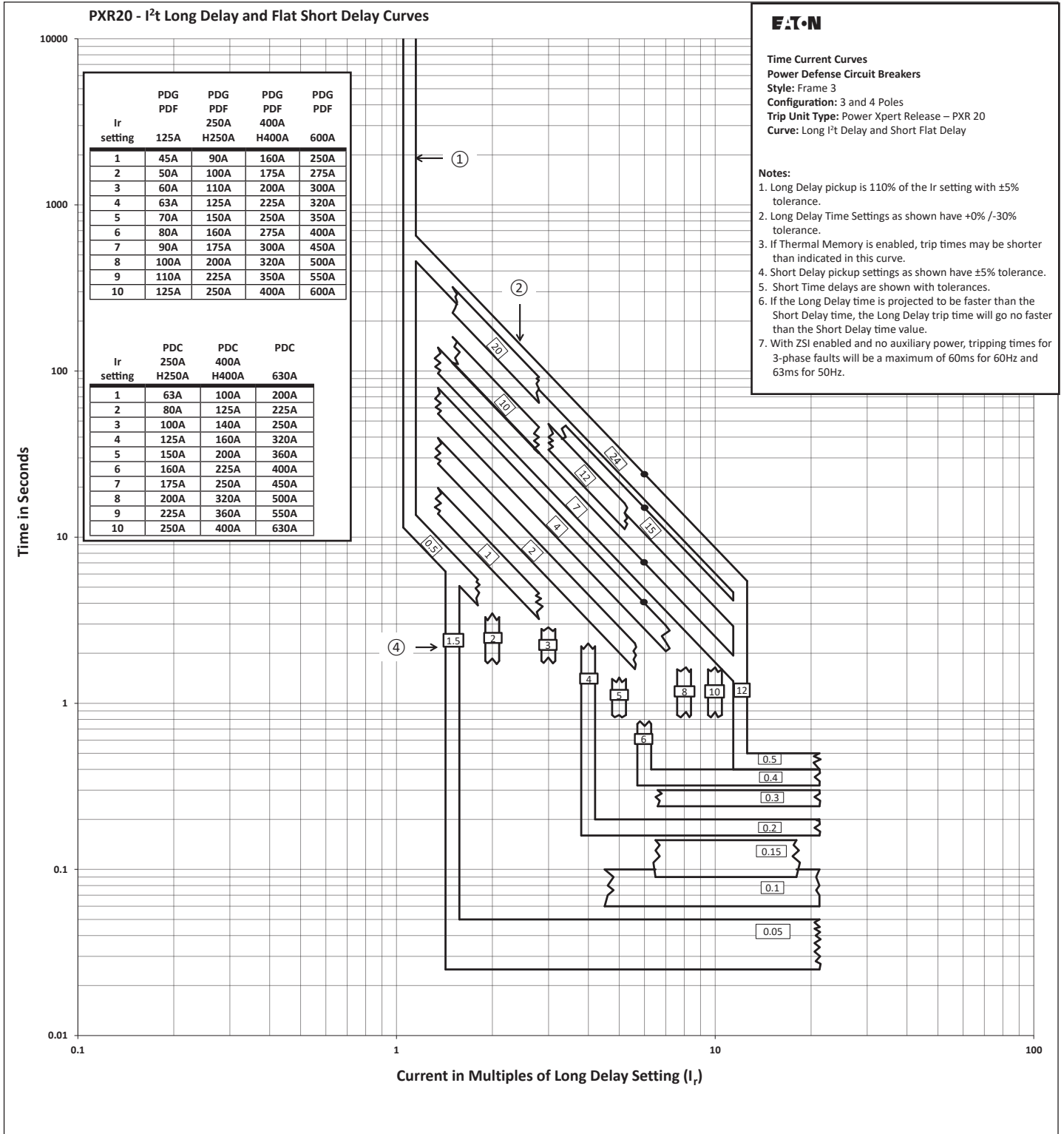

Figure 3. PXR 20 - I²t long delay and flat short delay.

November 2019

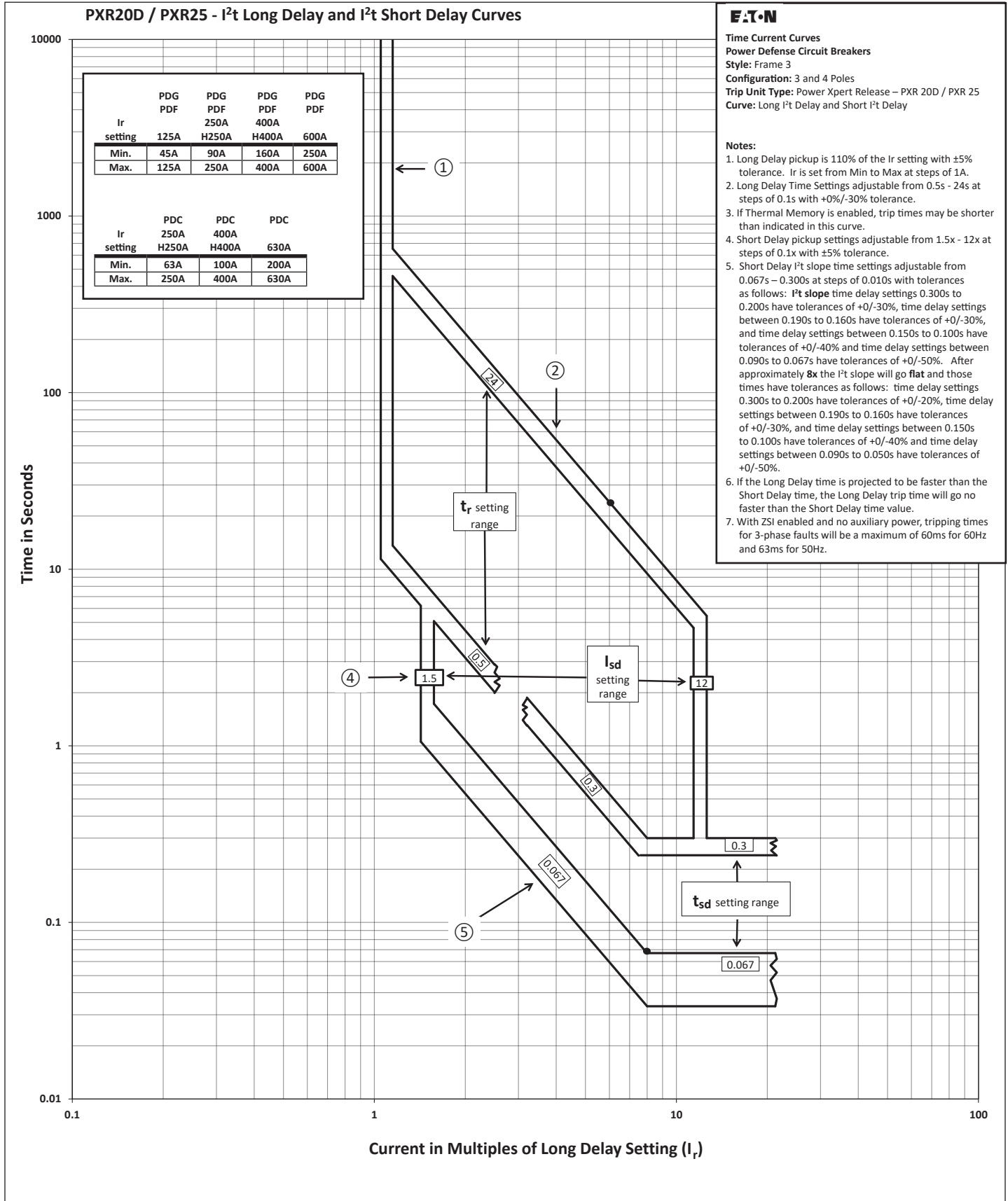

Figure 4. PXR 20D / PXR 25 - I²t long delay and I²t short delay.

November 2019

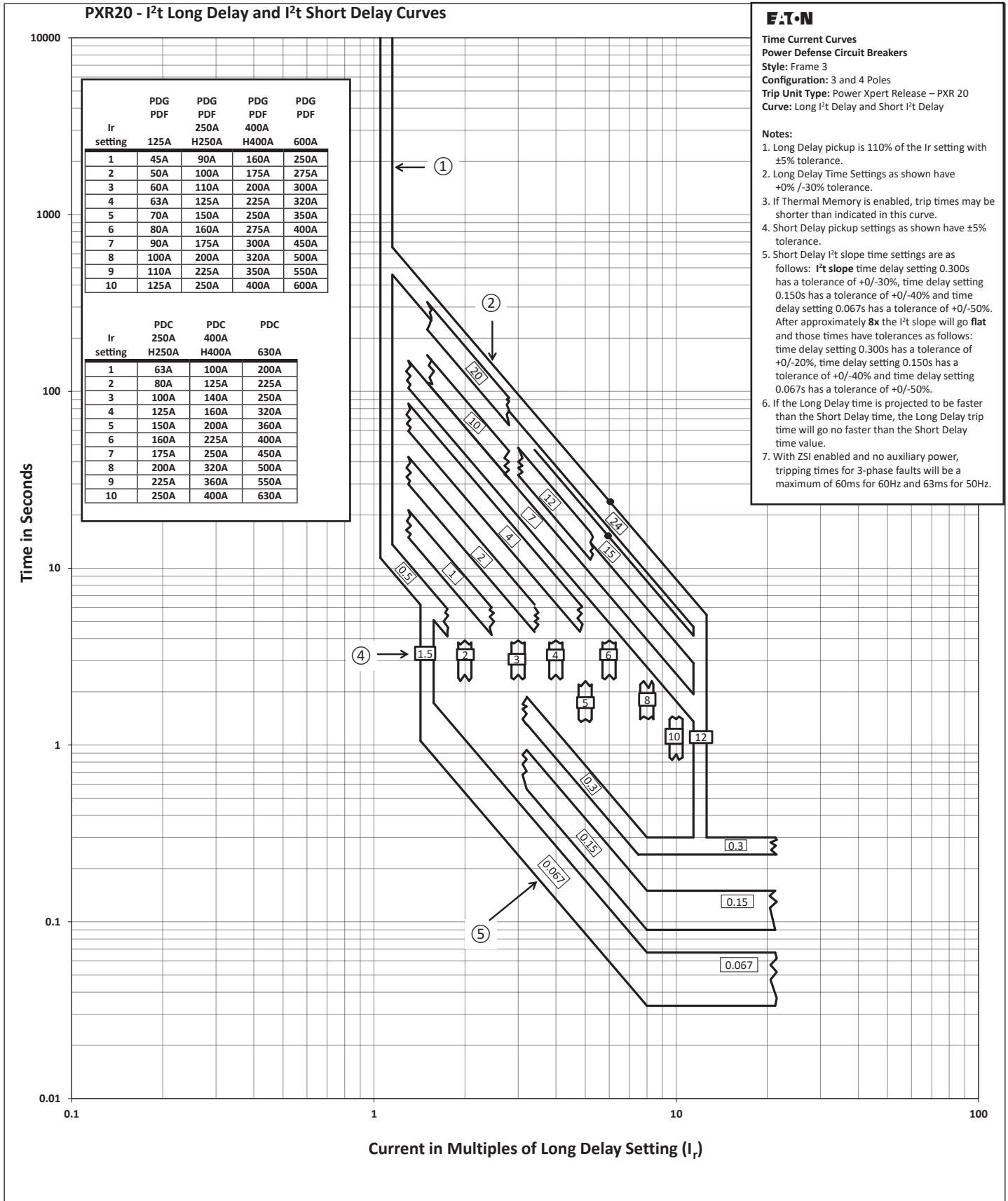

Figure 5. PXR 20 I²t long delay and I²t short delay.

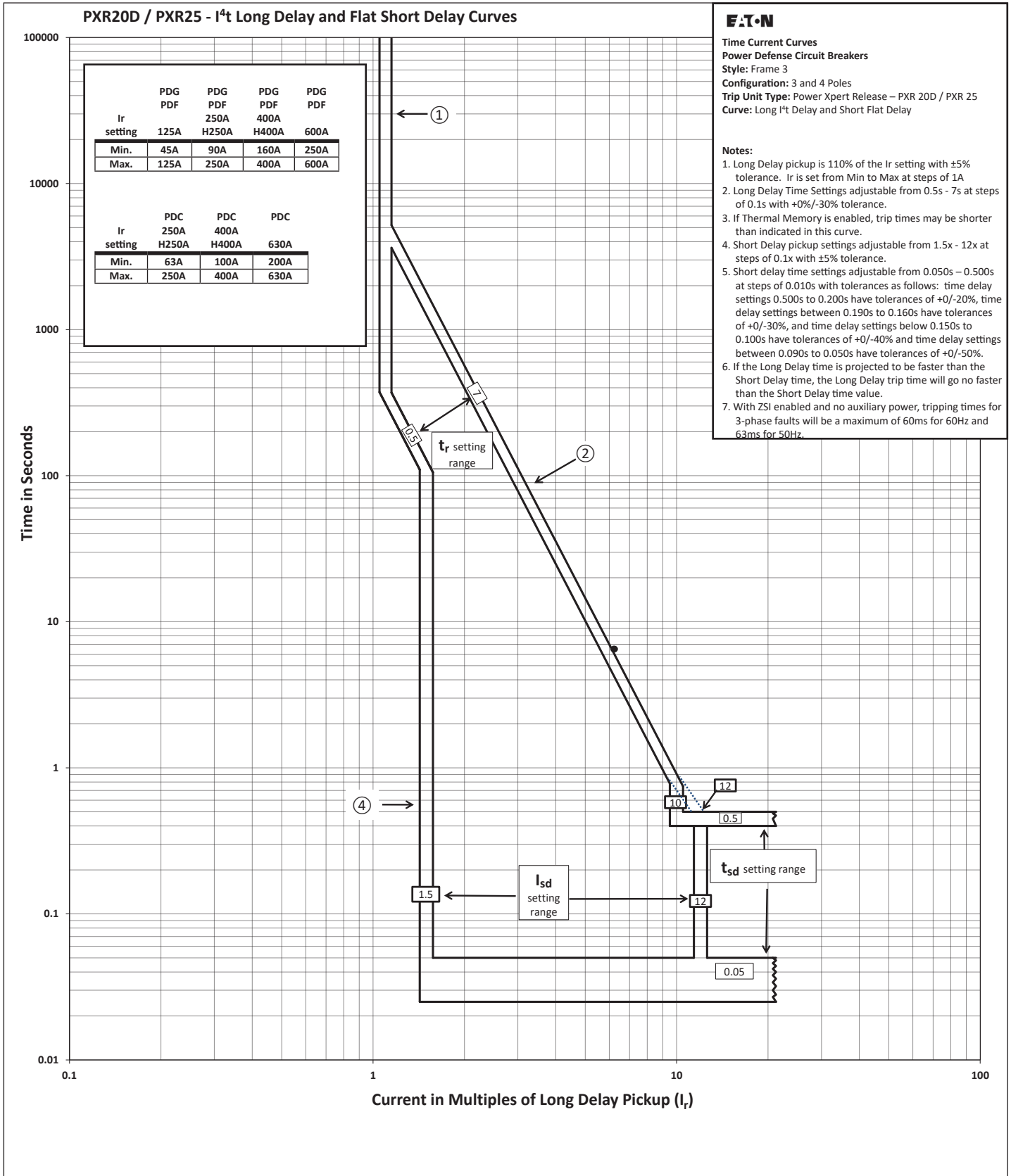

Figure 6. PXR 20D / PXR 25 - I⁴t long delay and flat short delay.

November 2019

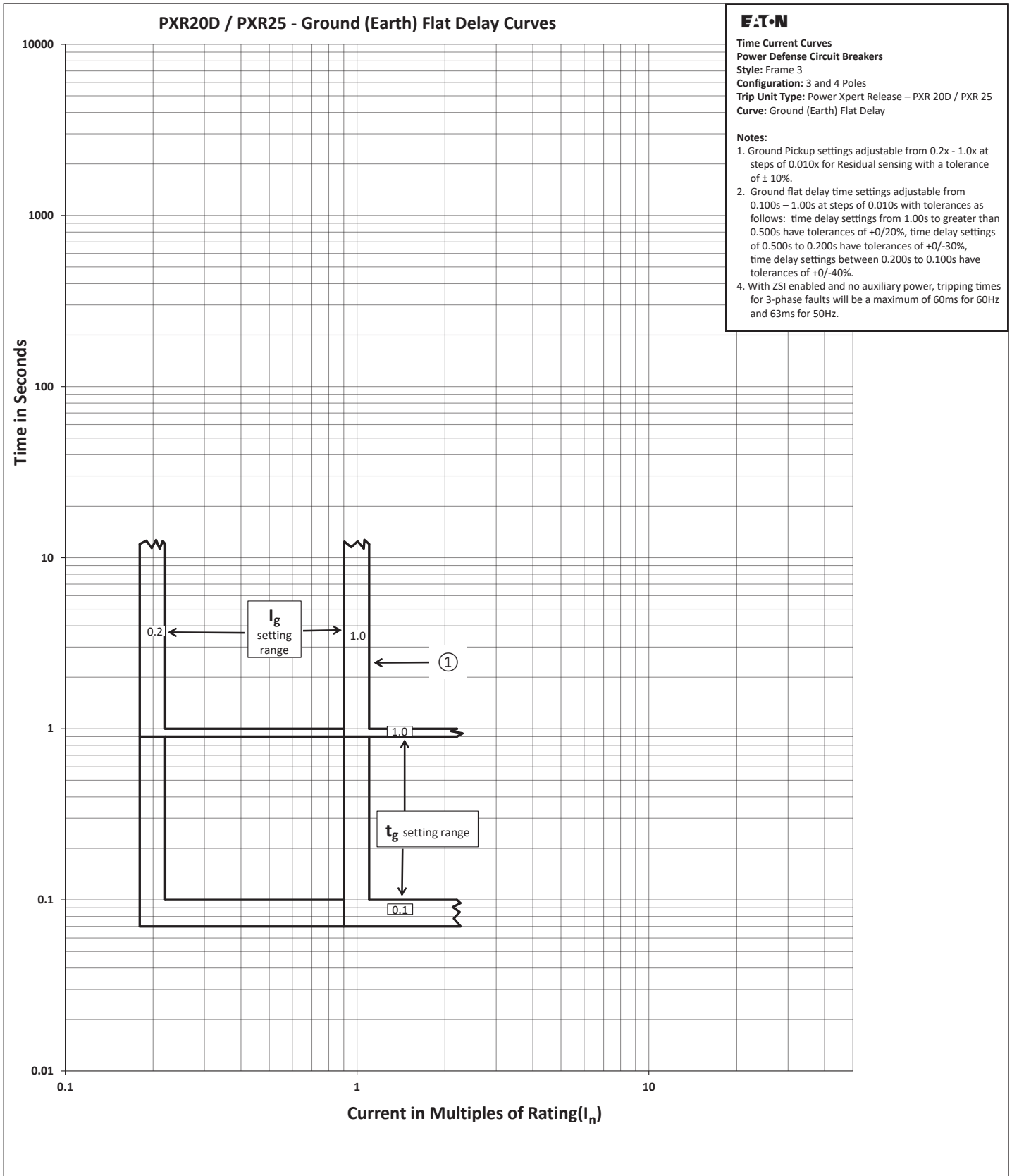

Figure 7. PXR 20D / PXR 25 ground (earth) flat delay.

November 2019

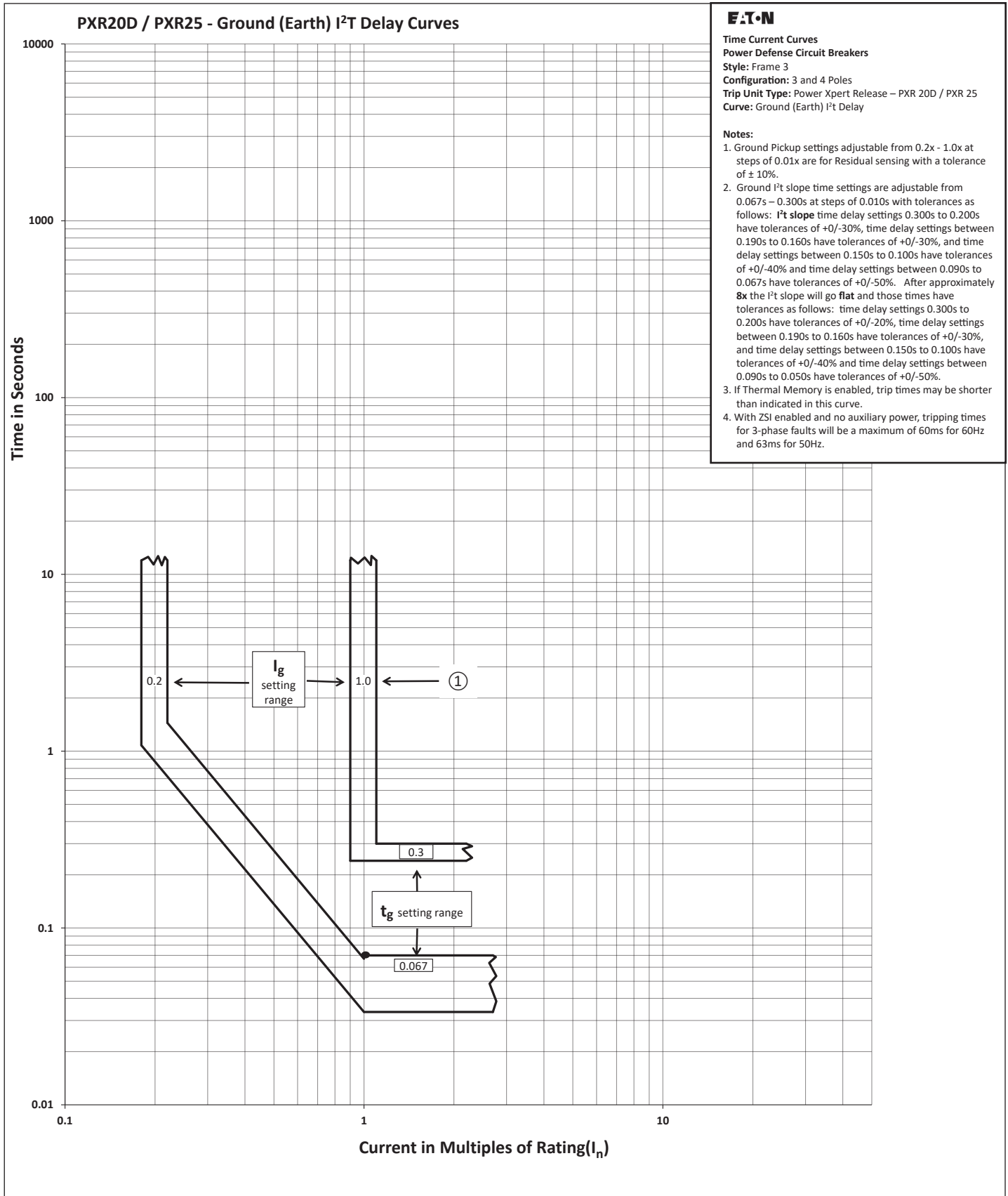

Figure 8. PXR 20D / PXR 25 -ground (earth) I²t delay.

November 2019

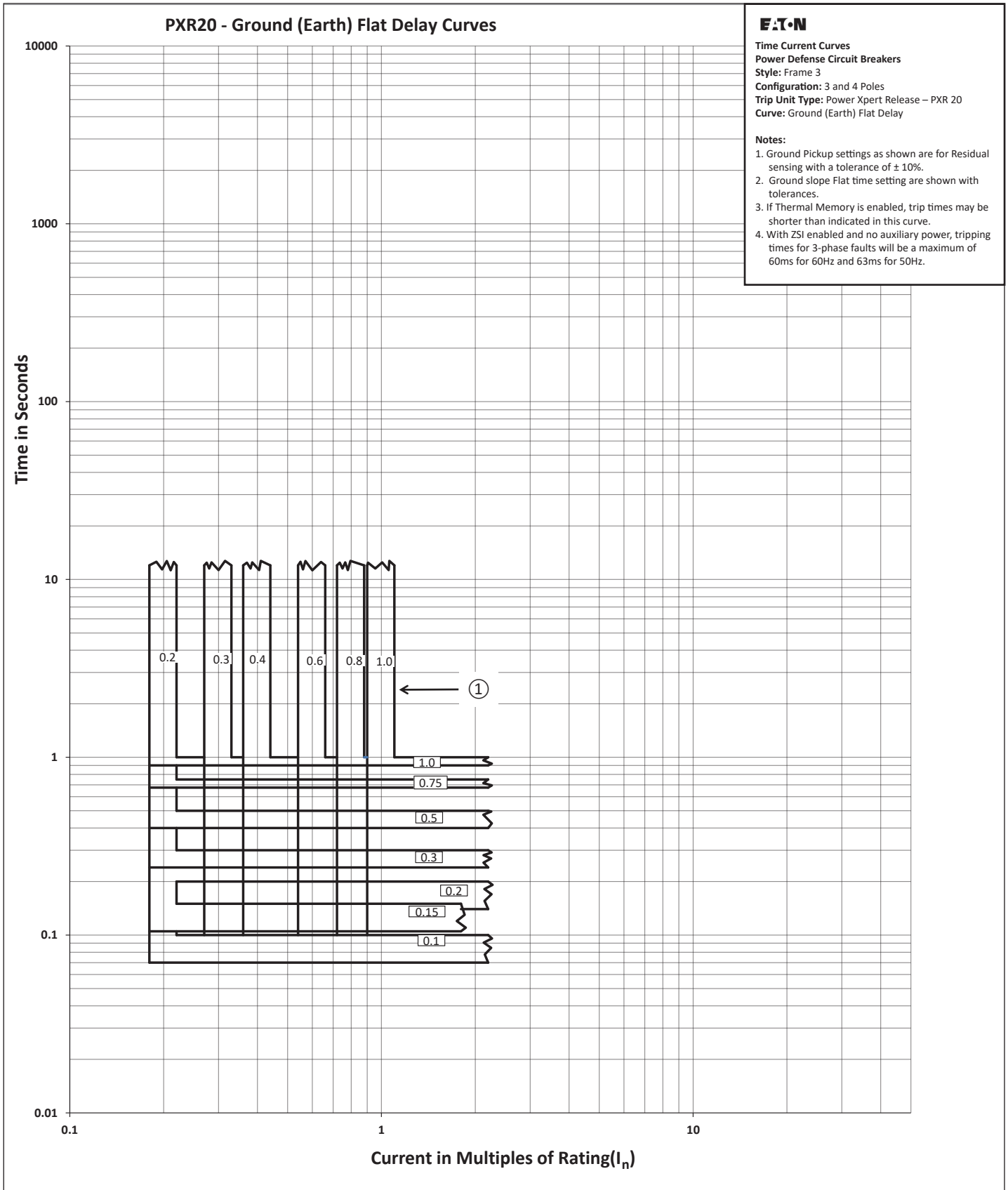

Figure 9. PXR 20 - ground (earth) flat delay.

November 2019

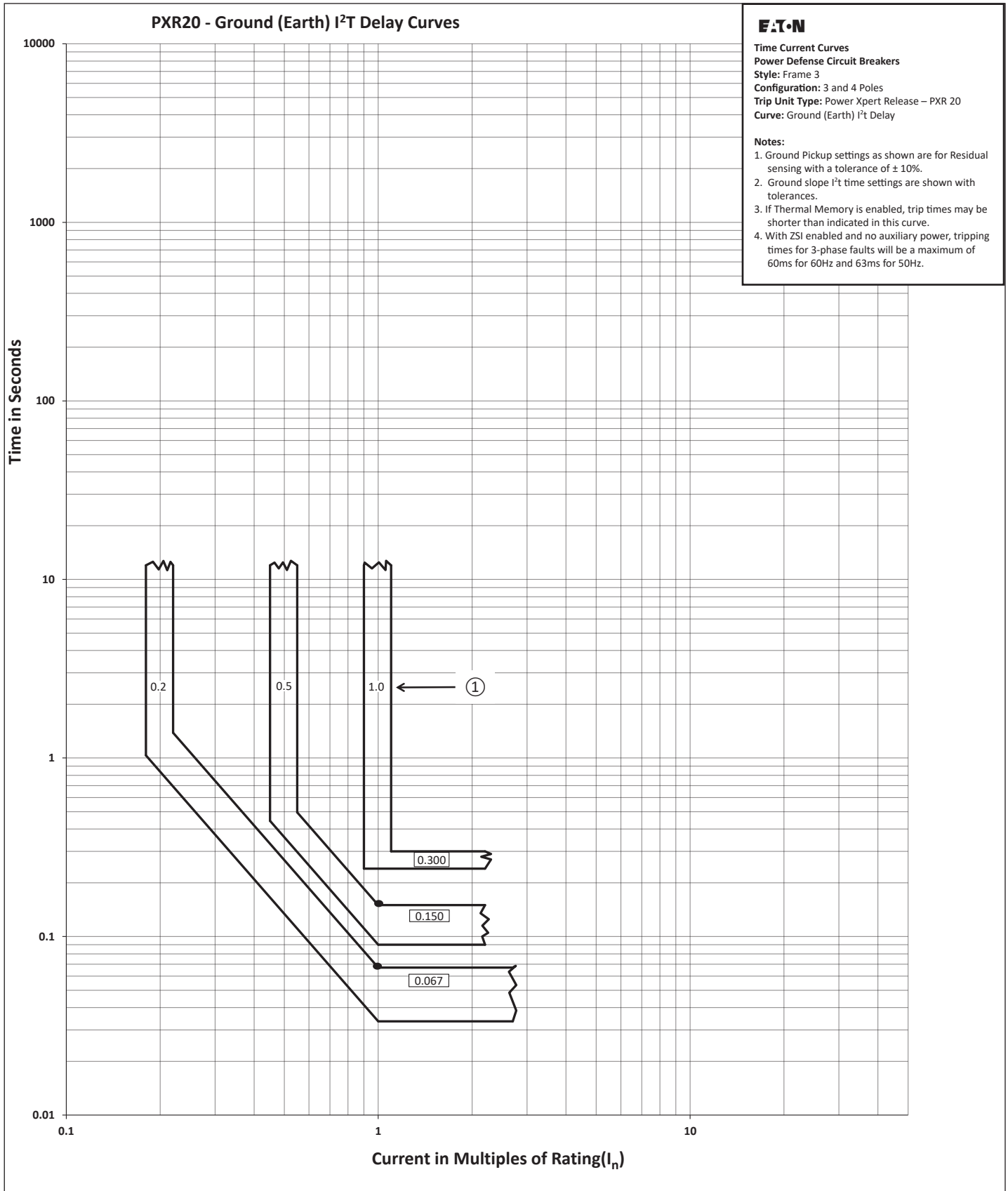

Figure 10. PXR 20 - ground (earth) I²t delay.

November 2019

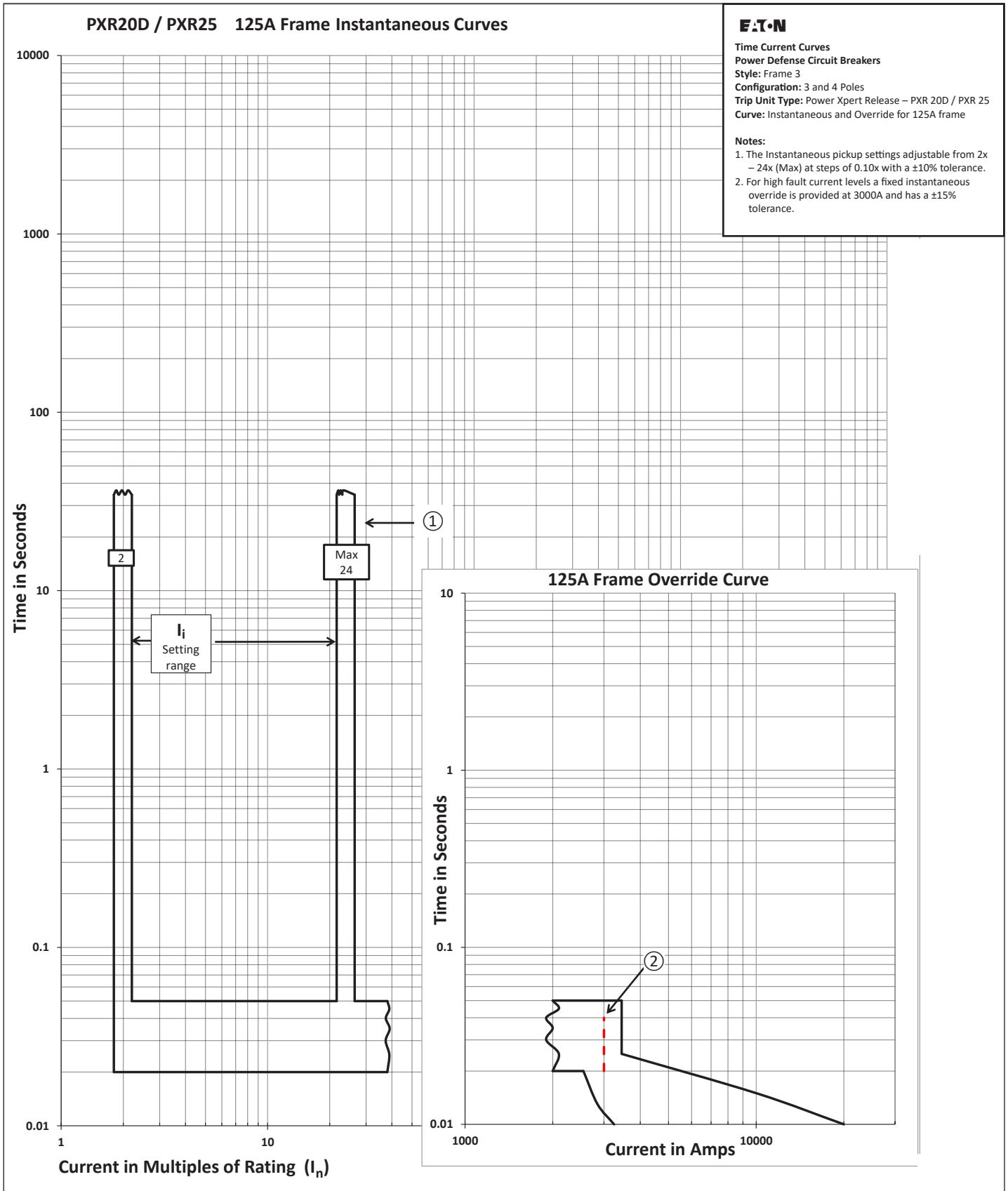

Figure 11. PXR 20D / PXR 25 - instantaneous and override for 125A frame.

November 2019

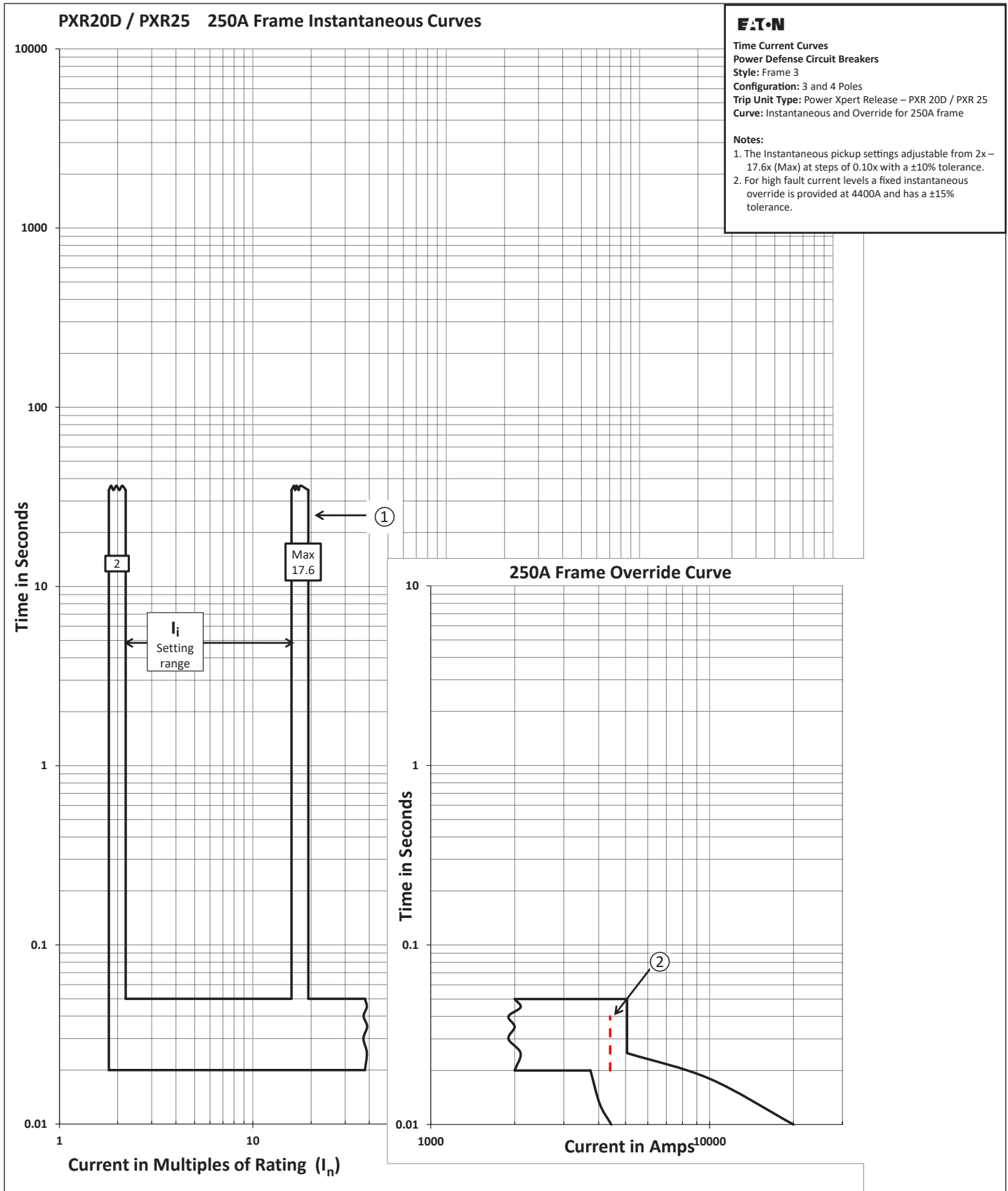

Figure 12. PXR 20D / PXR 25 - instantaneous and override for 250A frame.

November 2019

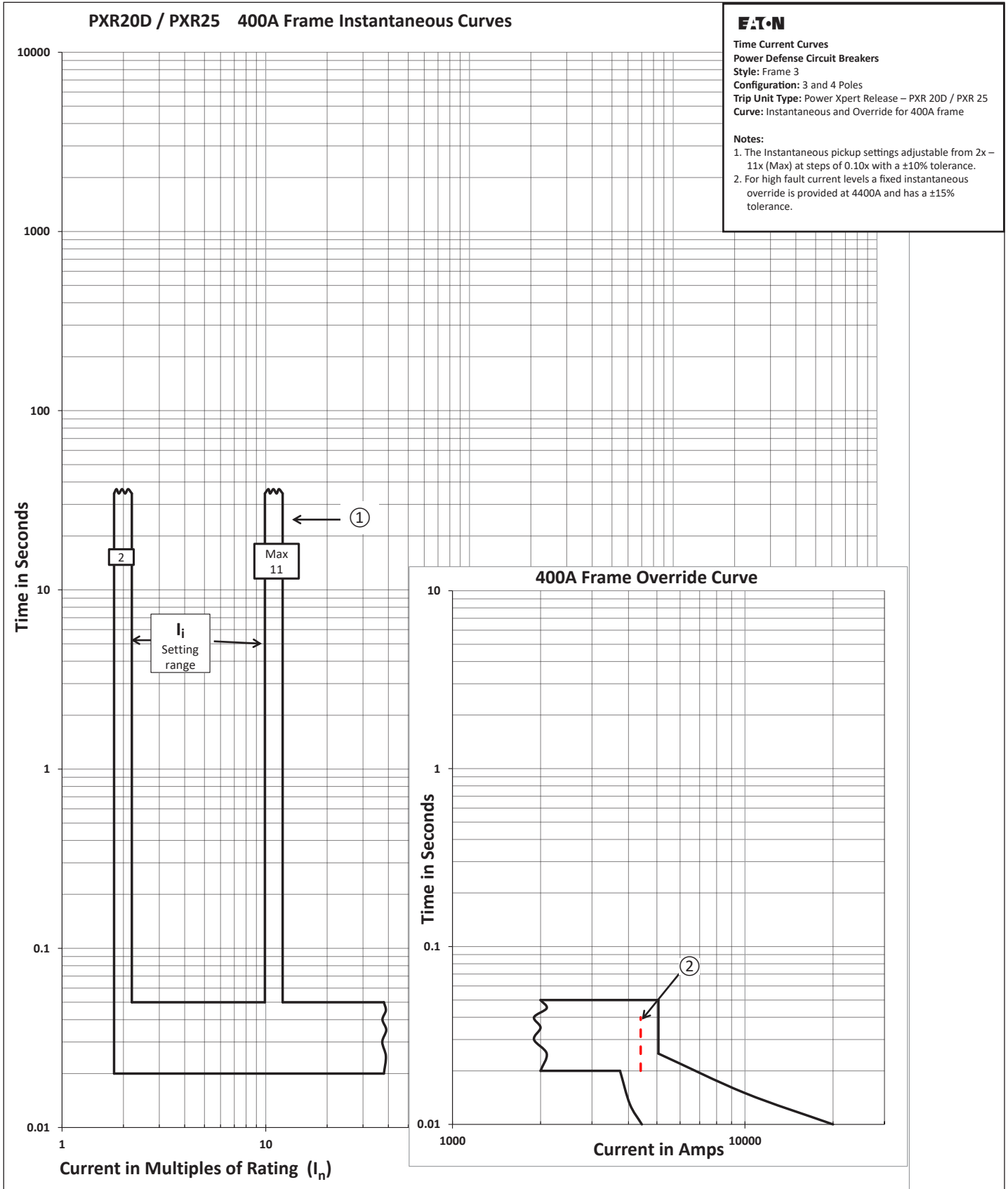

Figure 13. PXR 20D / PXR 25 - instantaneous and override for 400A frame.

November 2019

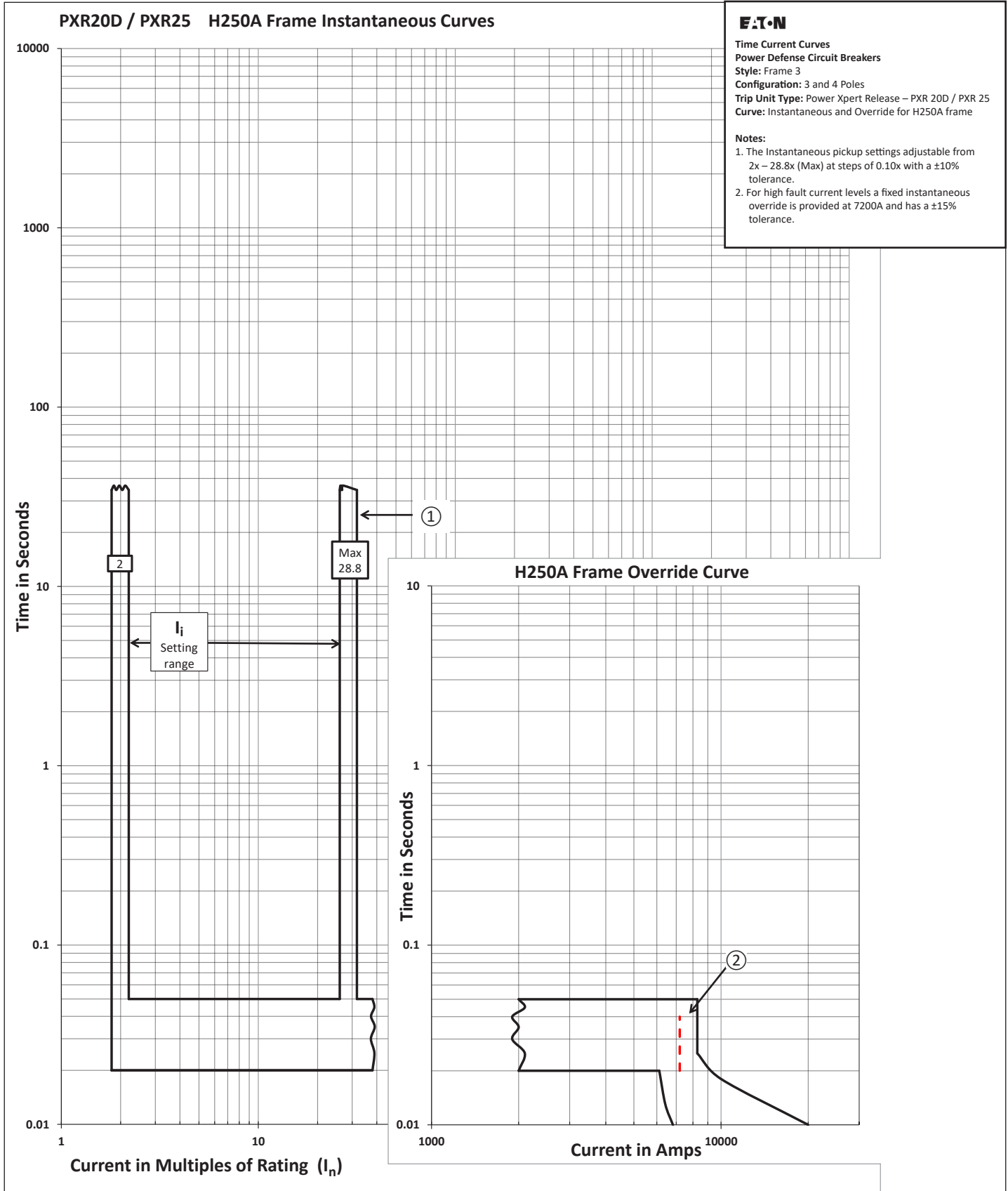

Figure 14. PXR 20D / PXR 25 - instantaneous and override for H250A frame.

November 2019

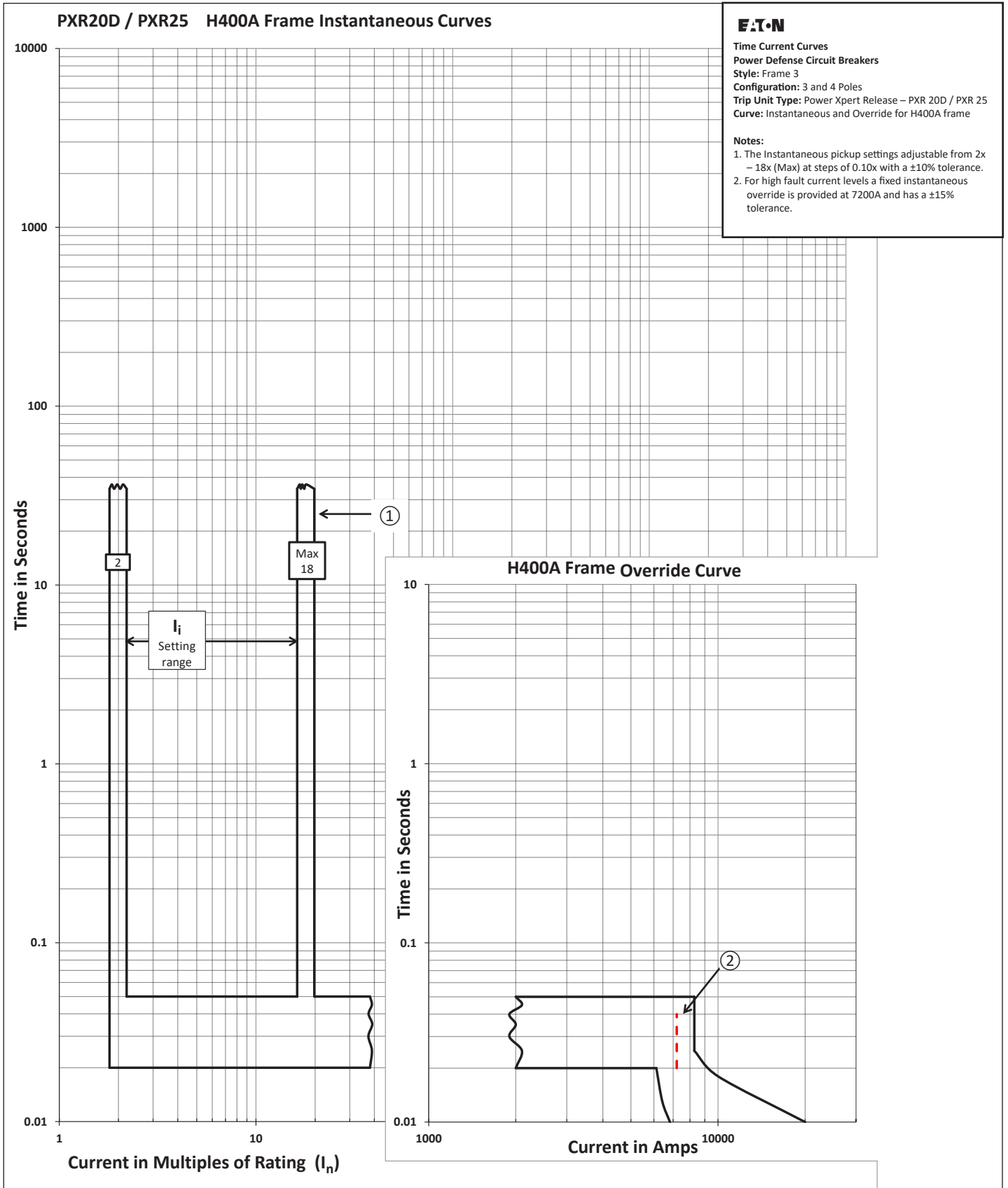

Figure 15. PXR 20D / PXR 25 - Instantaneous and override for H400A frame.

November 2019

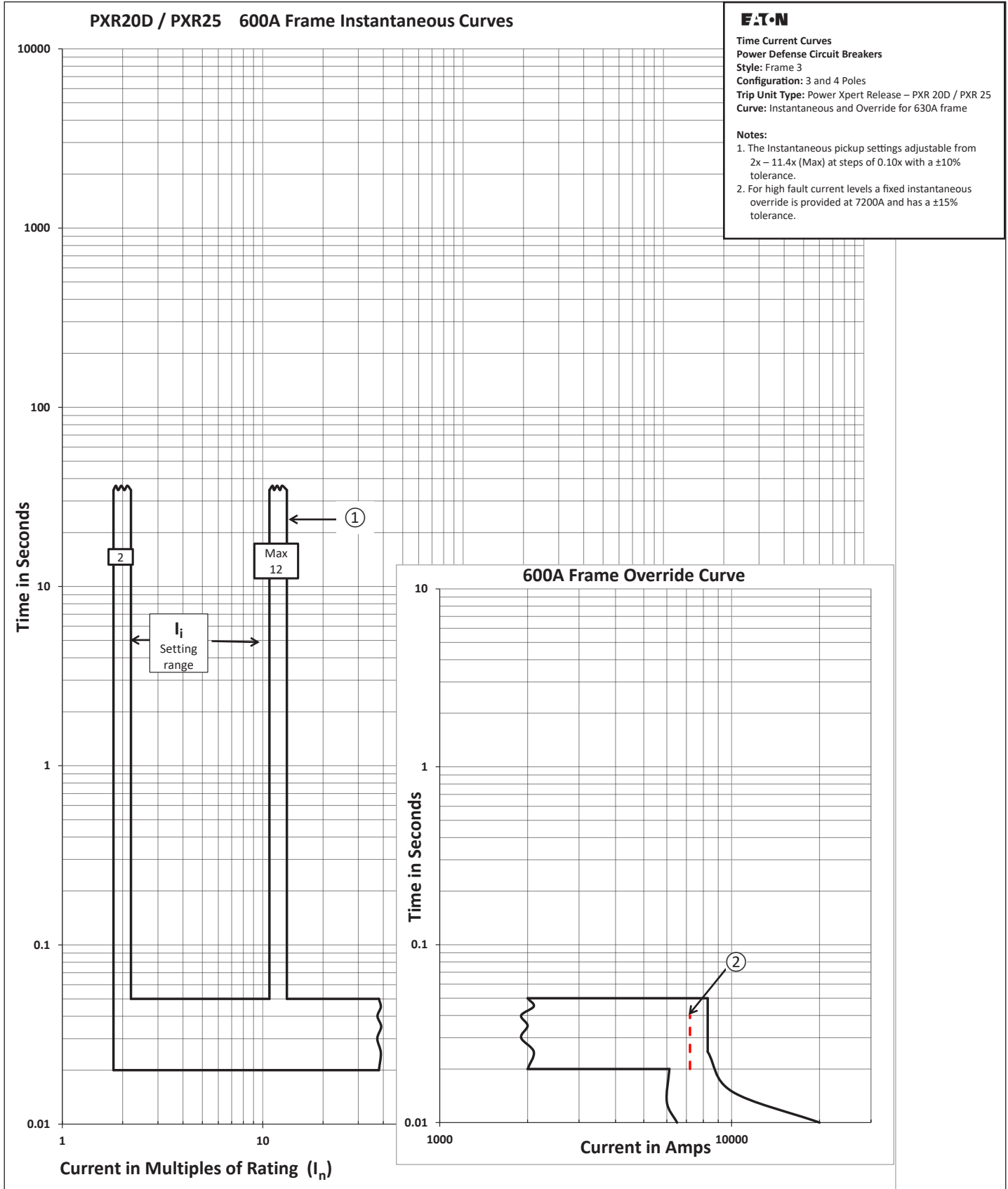

Figure 16. PXR 20D / PXR 25 - instantaneous and override for 600A frame.

November 2019

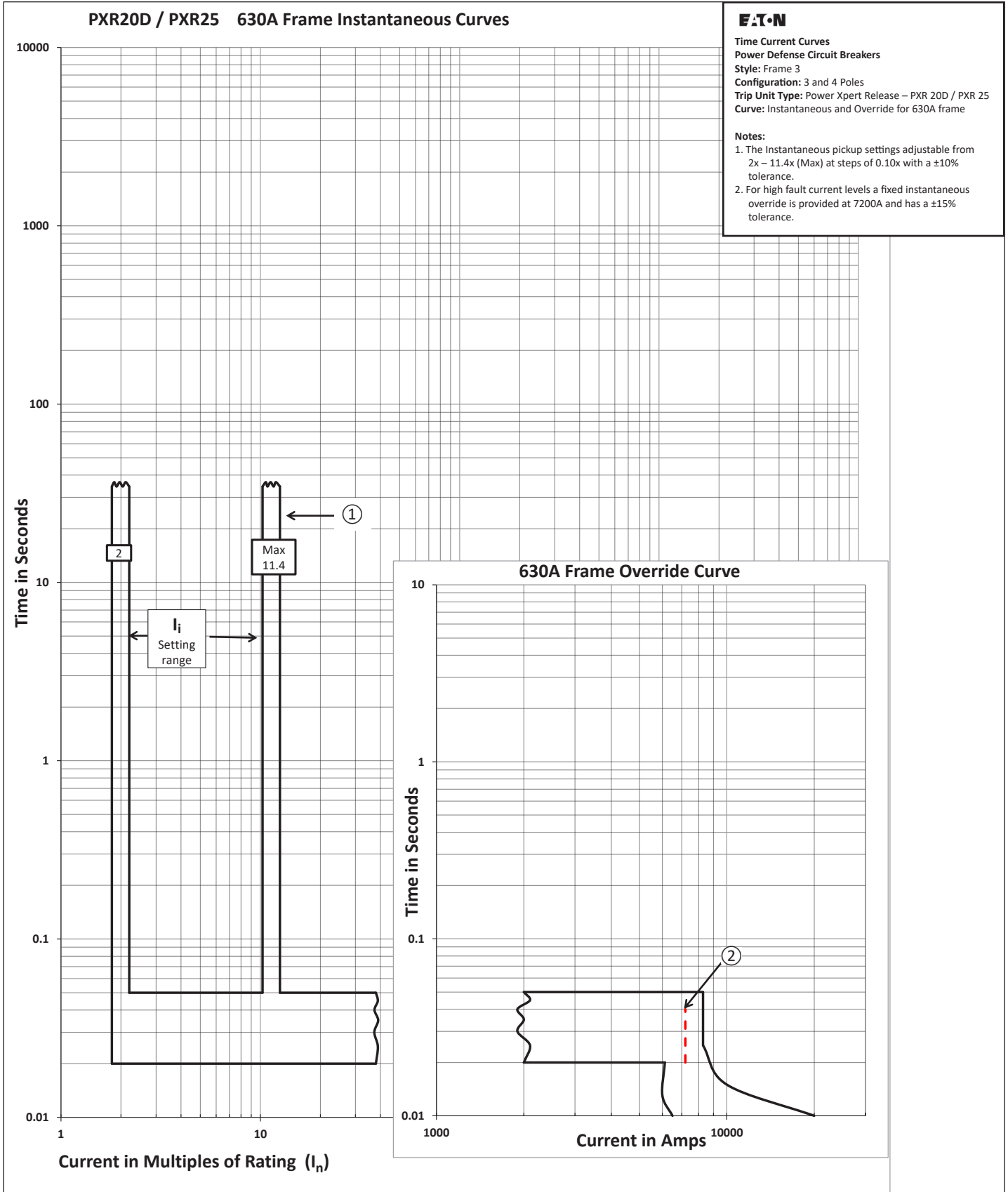

Figure 17. PXR 20D / PXR 25 -instantaneous and override for 630A frame.

November 2019

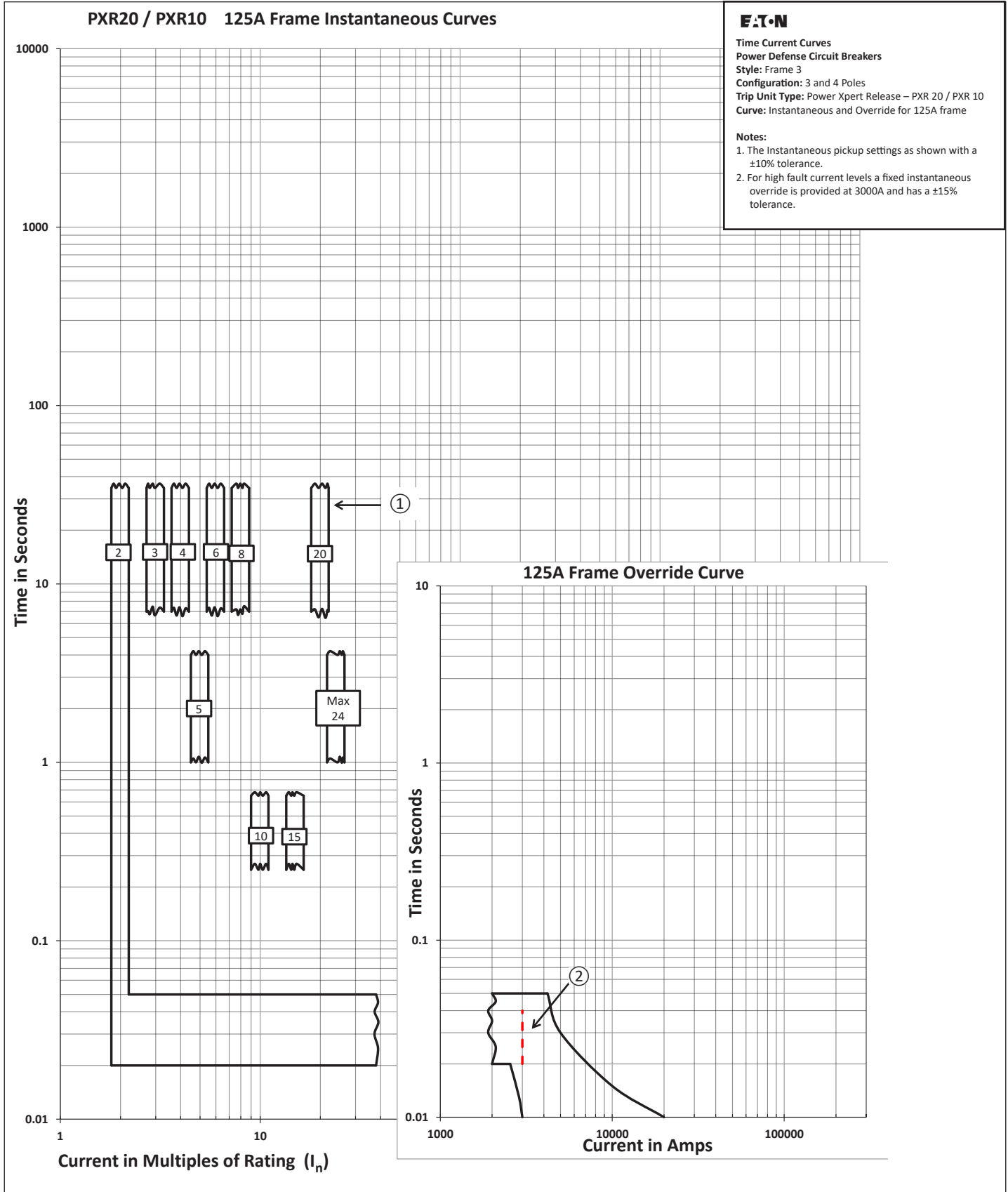

Figure 18. PXR 20 / PXR 10 - instantaneous and override for 125A frame.

November 2019

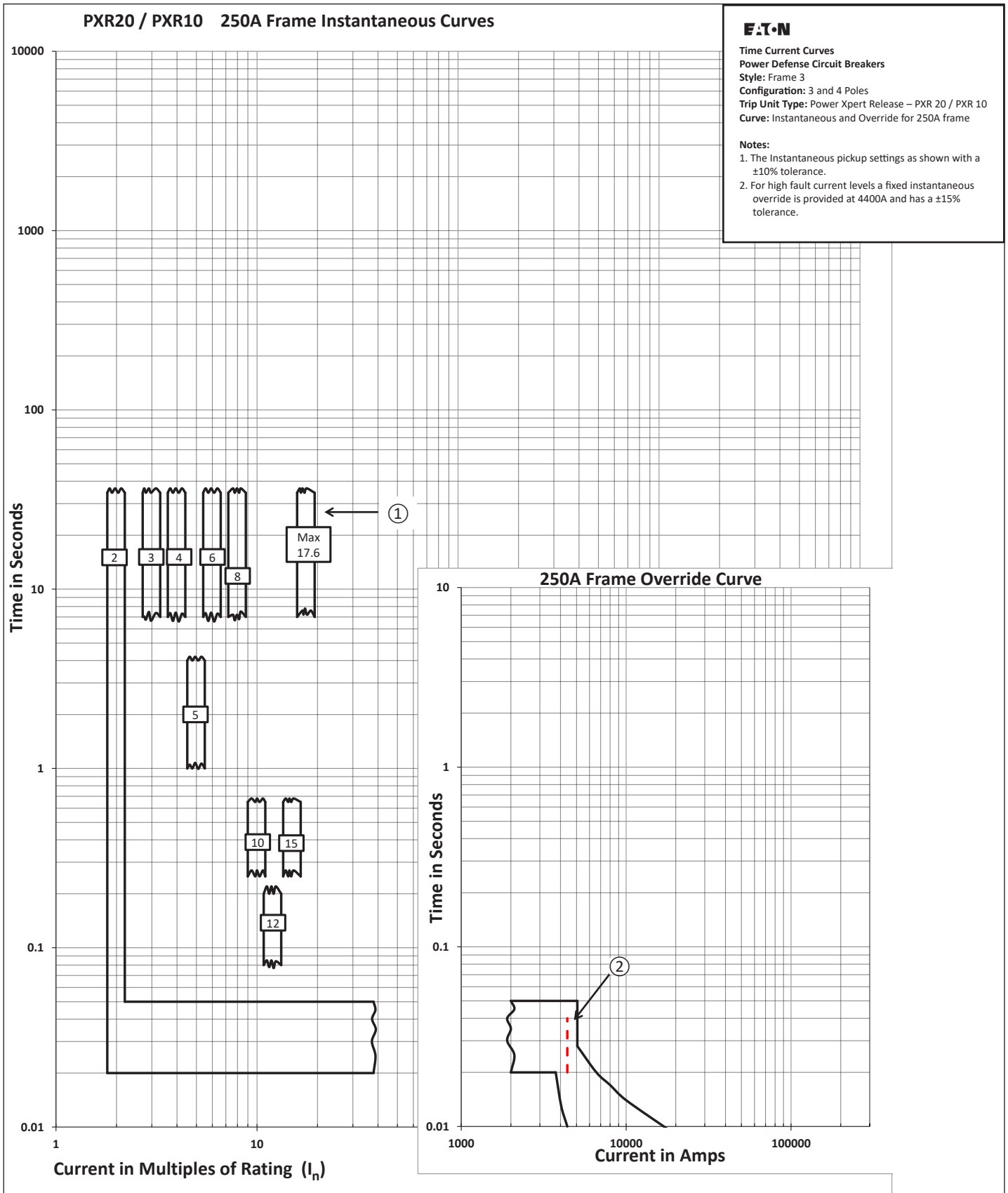

Figure 19. PXR 20 / PXR 10 - instantaneous and override for 250A frame.

November 2019

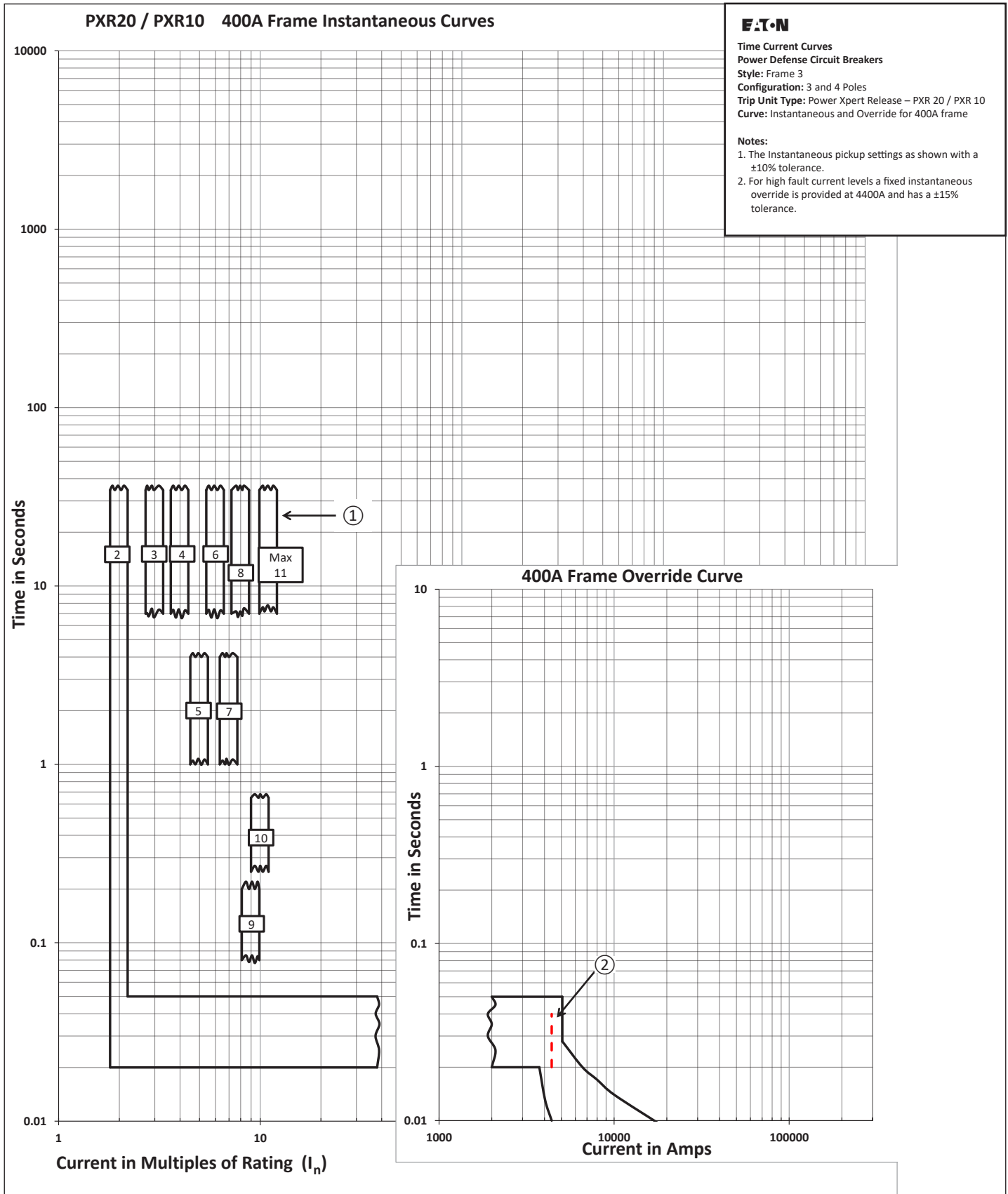

Figure 20. PXR 20 / PXR 10 - instantaneous and override for 400A frame.

November 2019

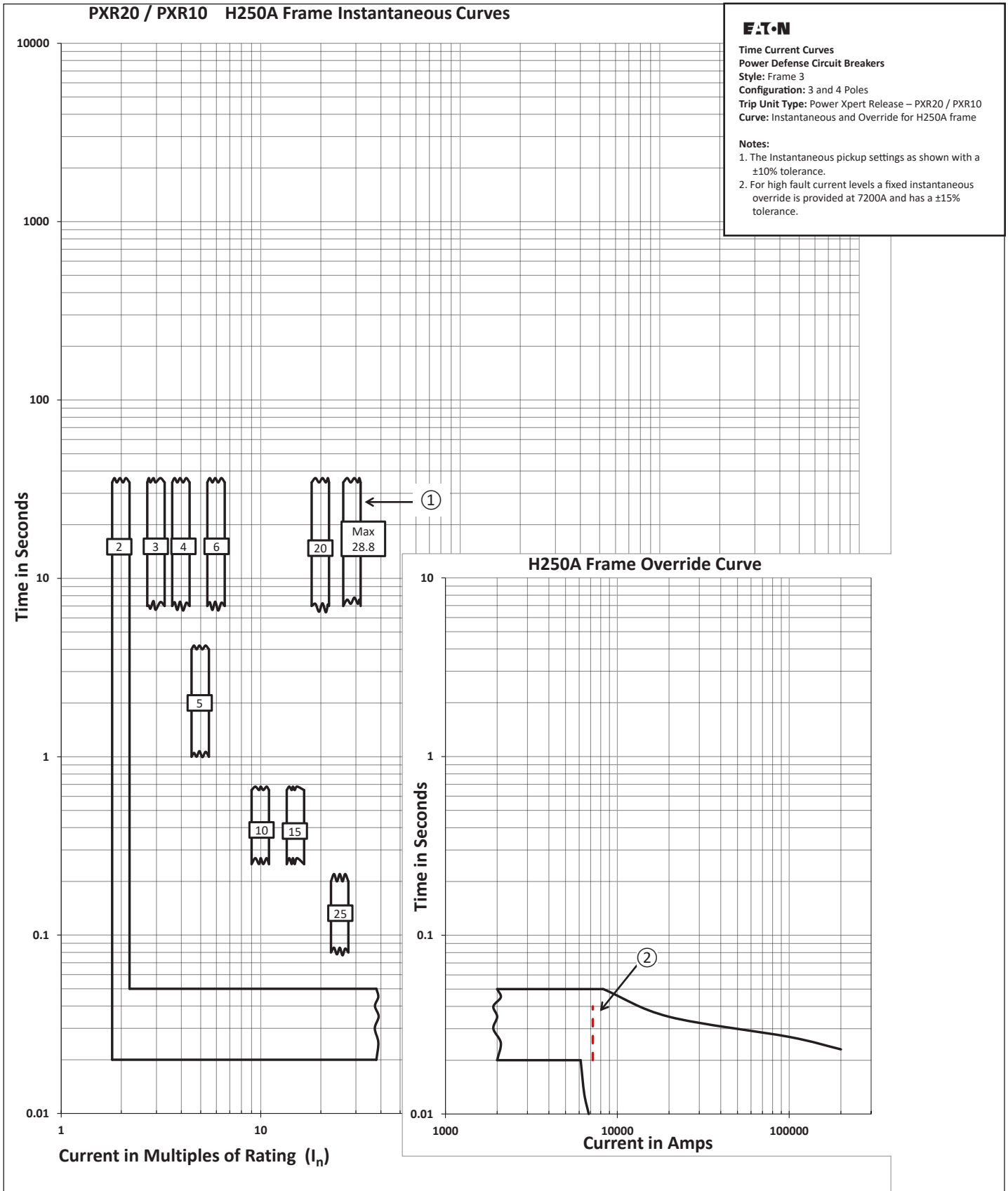

Figure 21. PXR 20 / PXR 10 - instantaneous and override for H250A frame.

November 2019

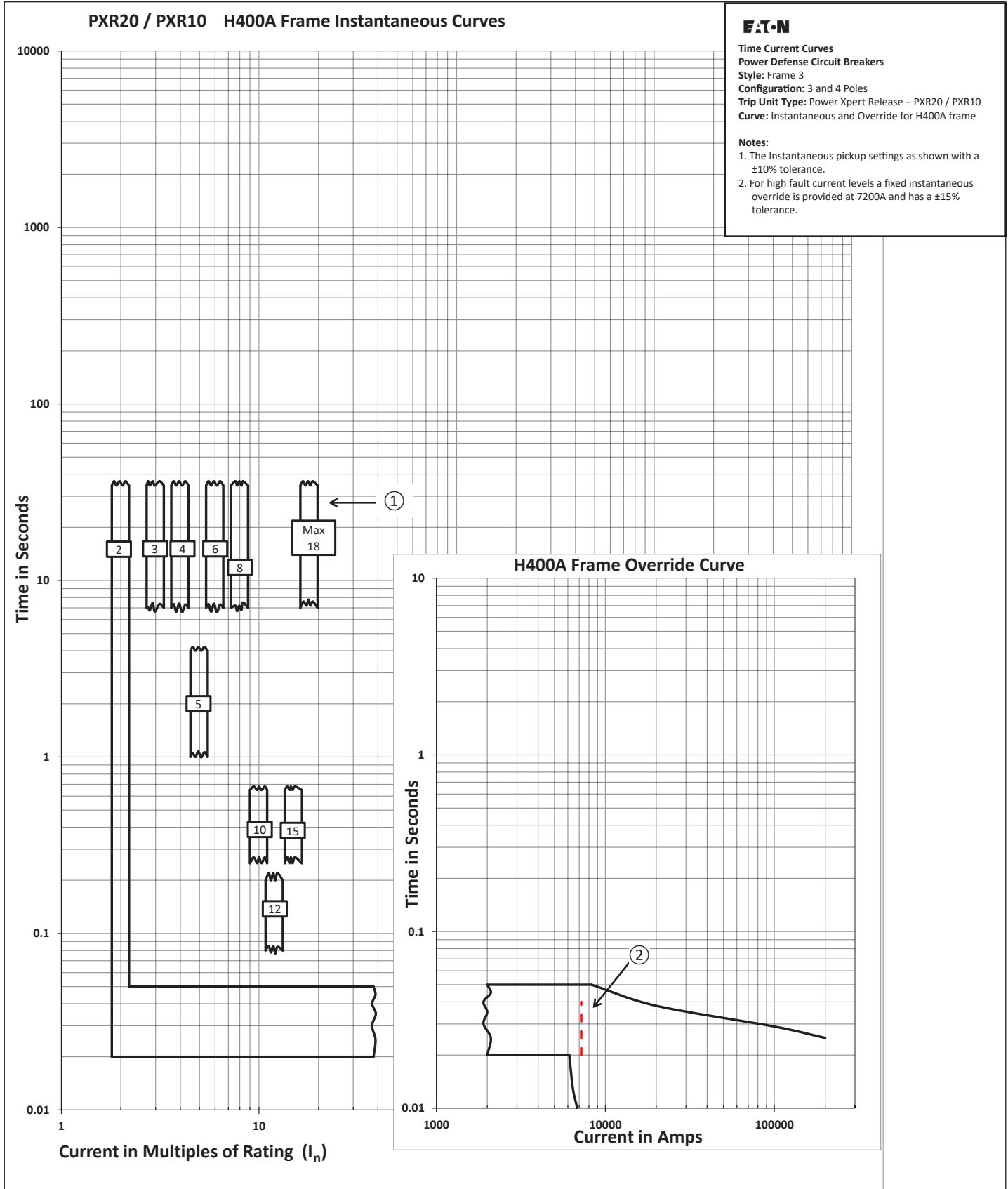

Figure 22. PXR 20 / PXR 10 - instantaneous and override for H400A frame.

November 2019

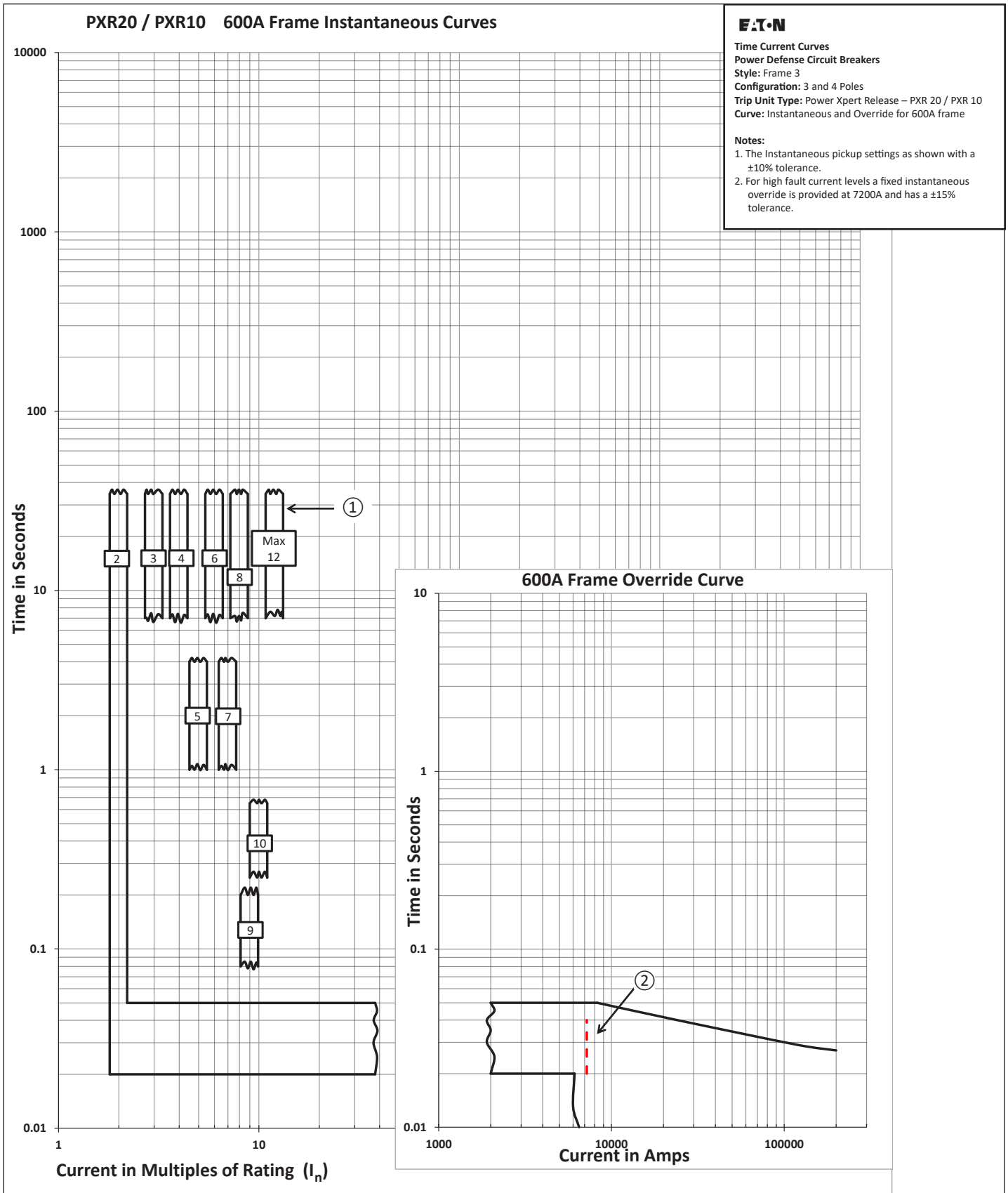

Figure 23. PXR 20 / PXR 10 - instantaneous and override for 600A frame.

November 2019

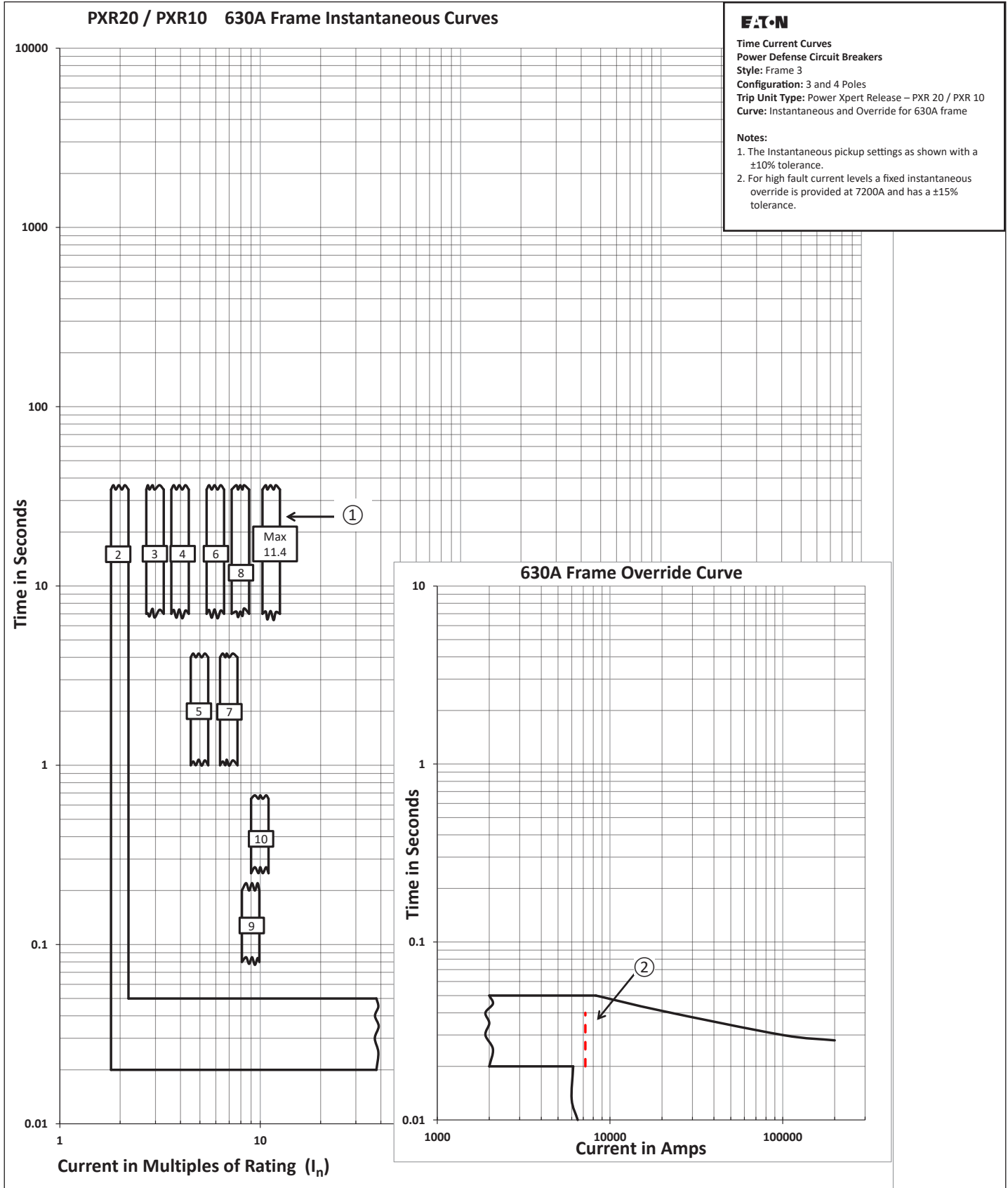

Figure 24. PXR 20 / PXR 10 - instantaneous and override for 630A frame.

November 2019

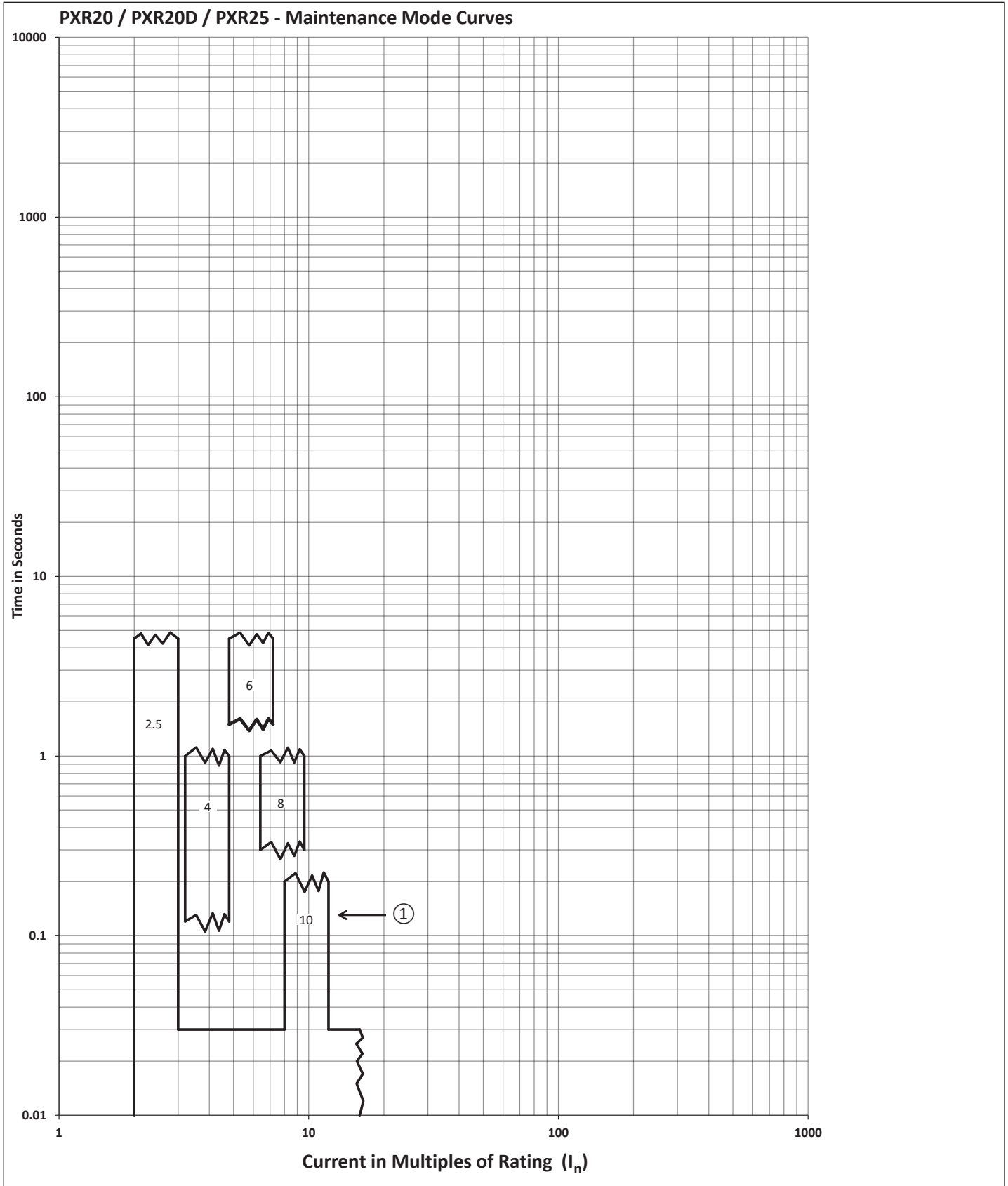

Figure 25. PXR 20 / PXR 20D / PXR 25 - maintenance mode.

November 2019

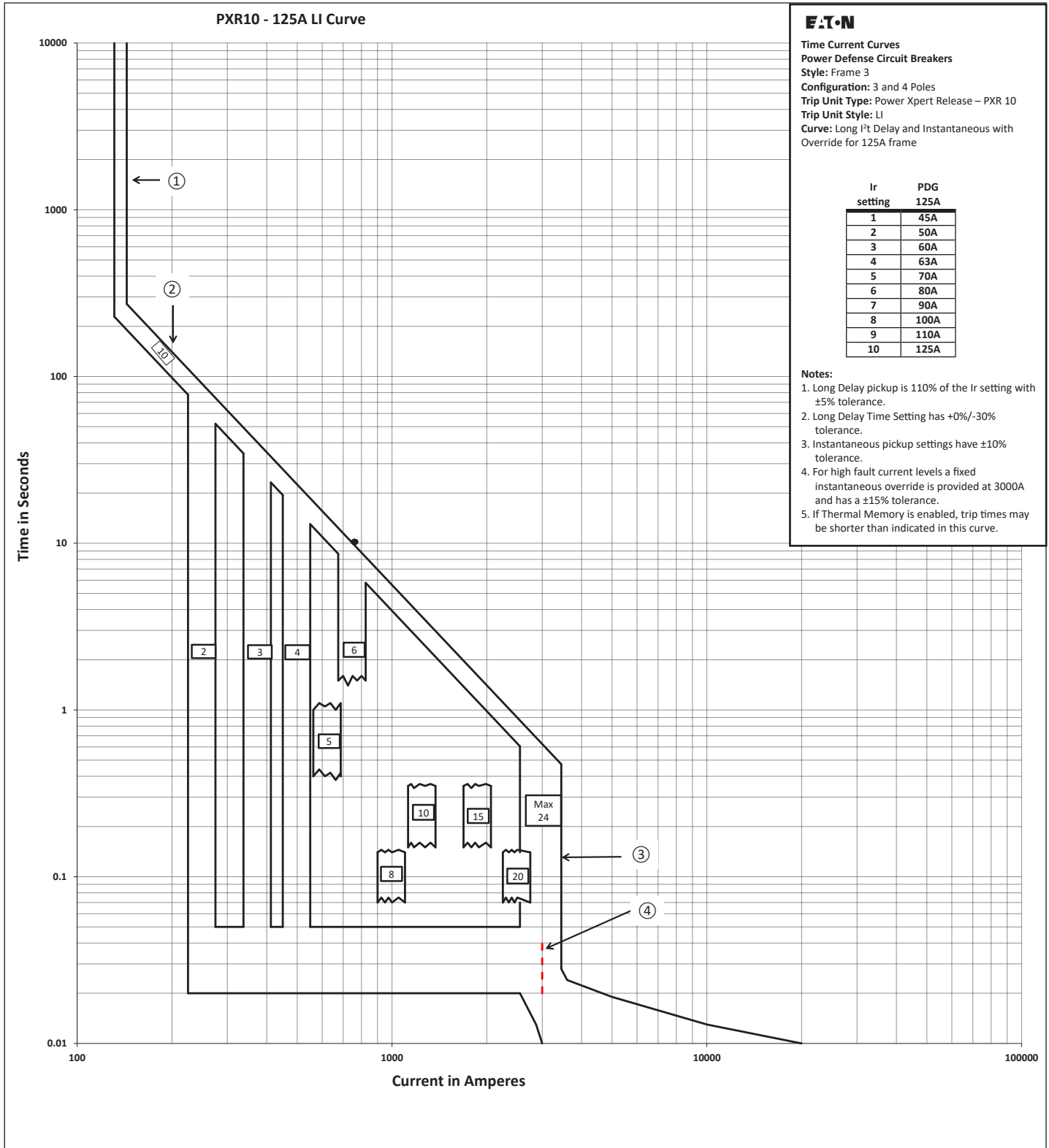

Figure 26. PXR 10 LI 125A frame.

November 2019

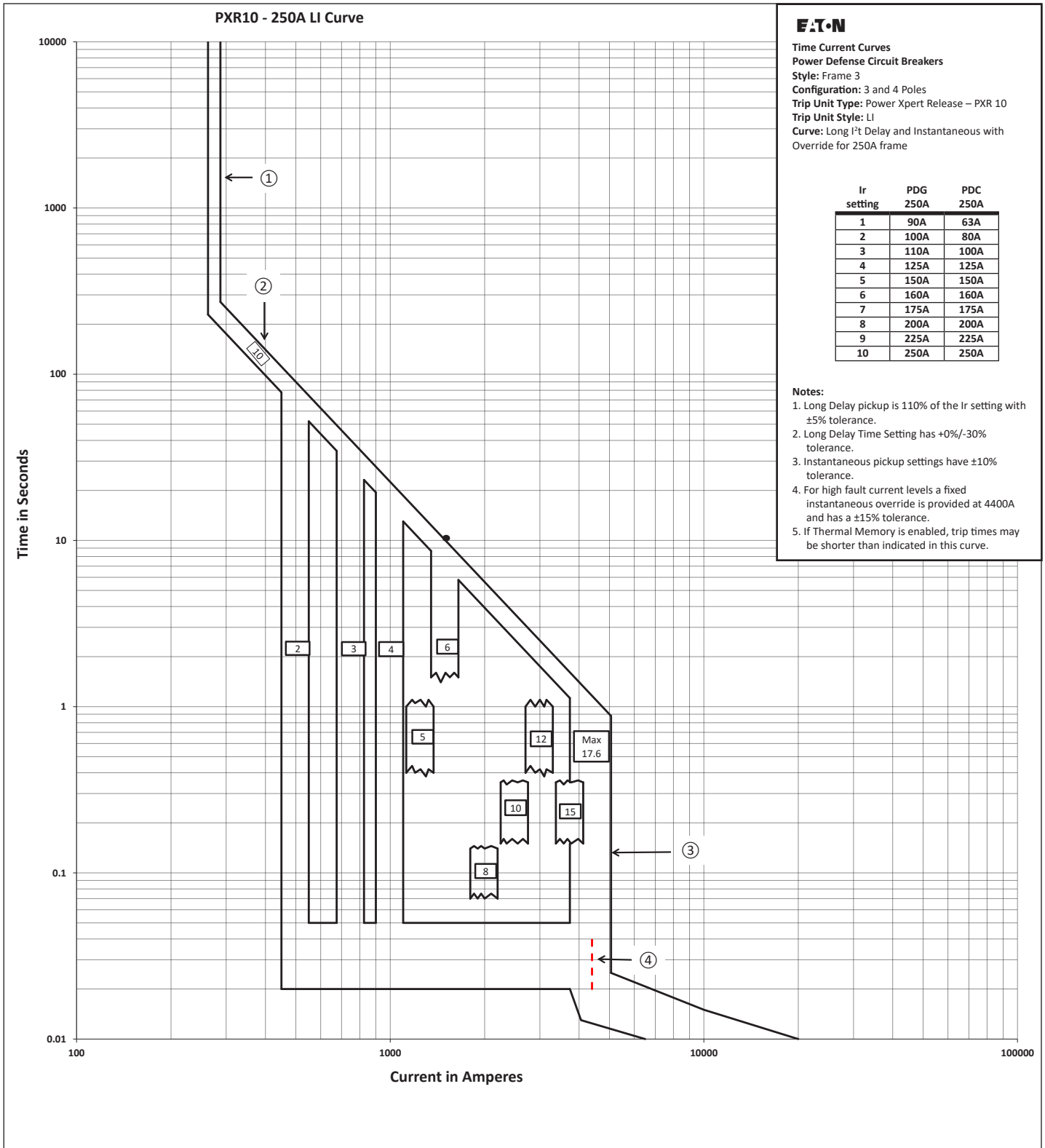

Figure 27. PXR 10 LI 250A frame.

November 2019

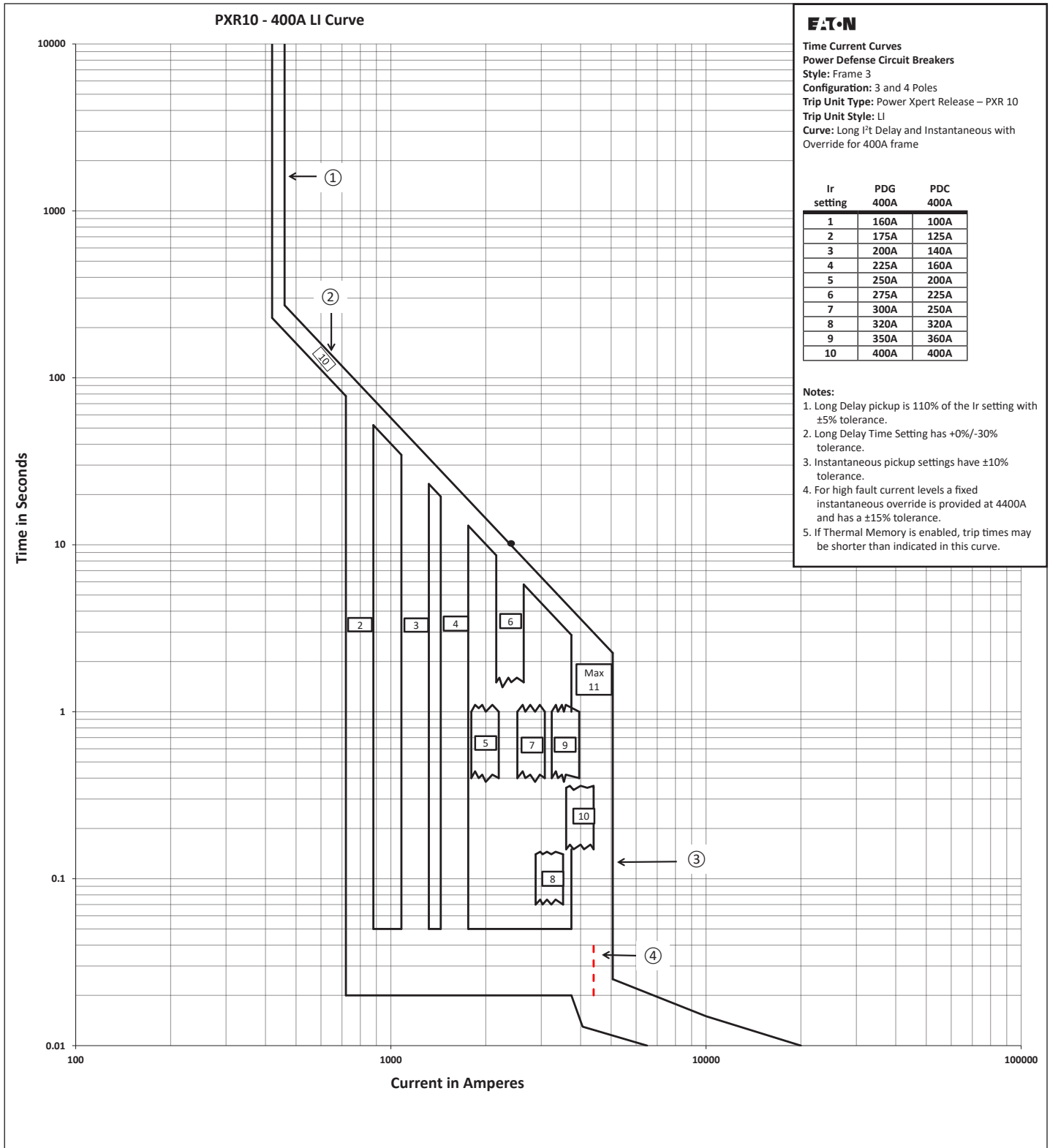

Figure 28. PXR 10 LI 400A frame.

November 2019

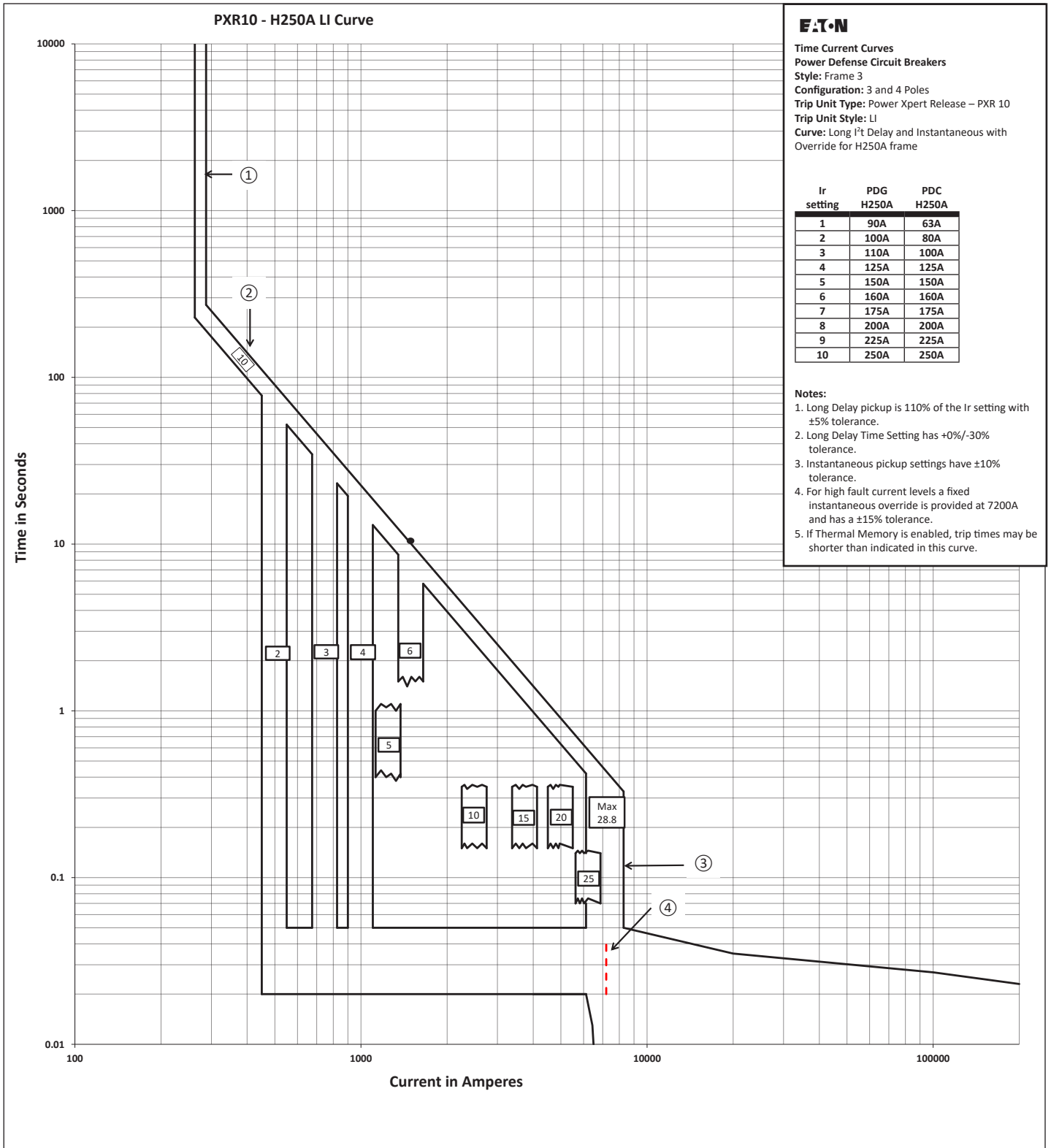

Figure 29. PXR 10 LI H250A frame.

November 2019

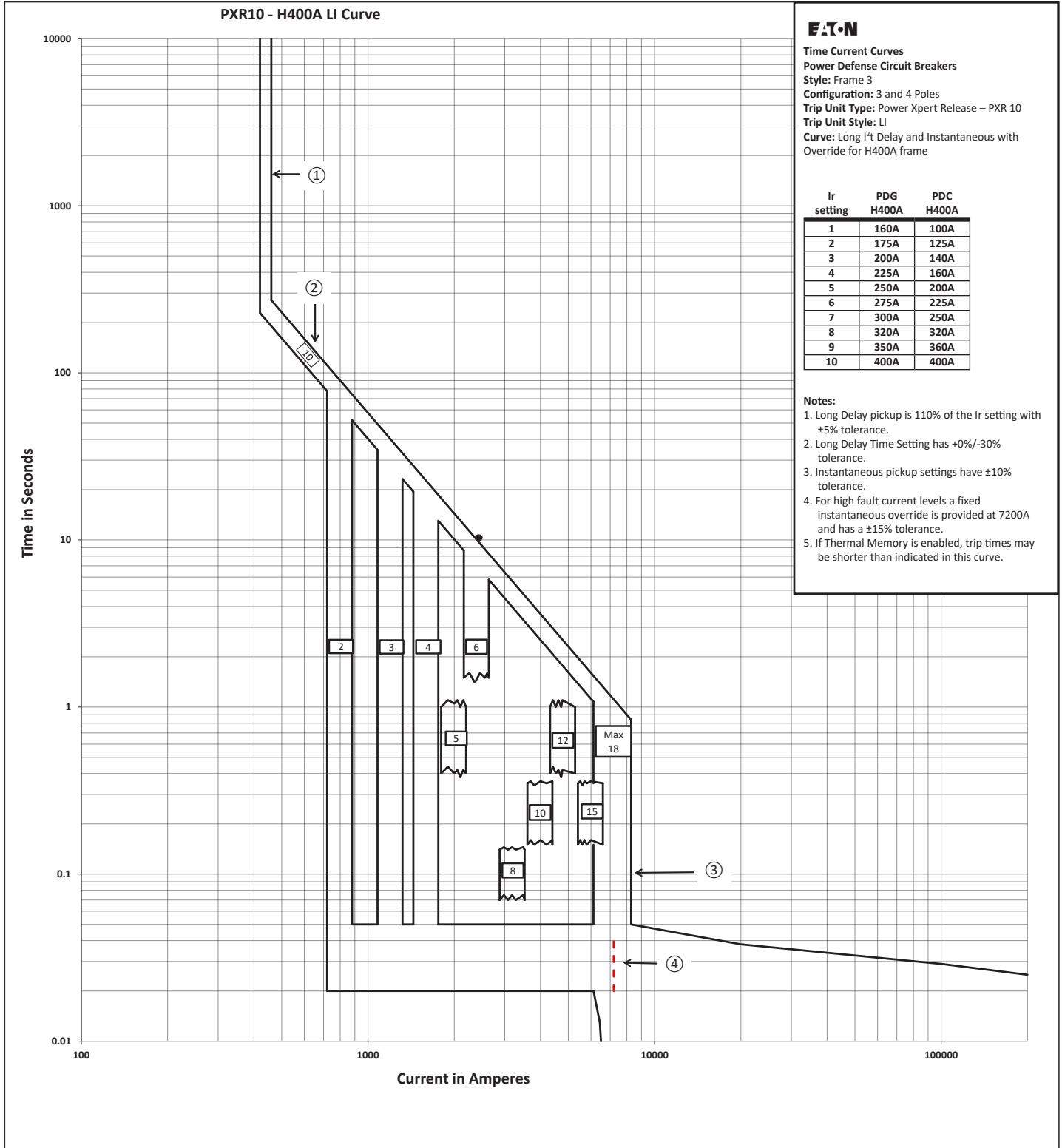

Figure 30. PXR 10 LI H400A frame.

November 2019

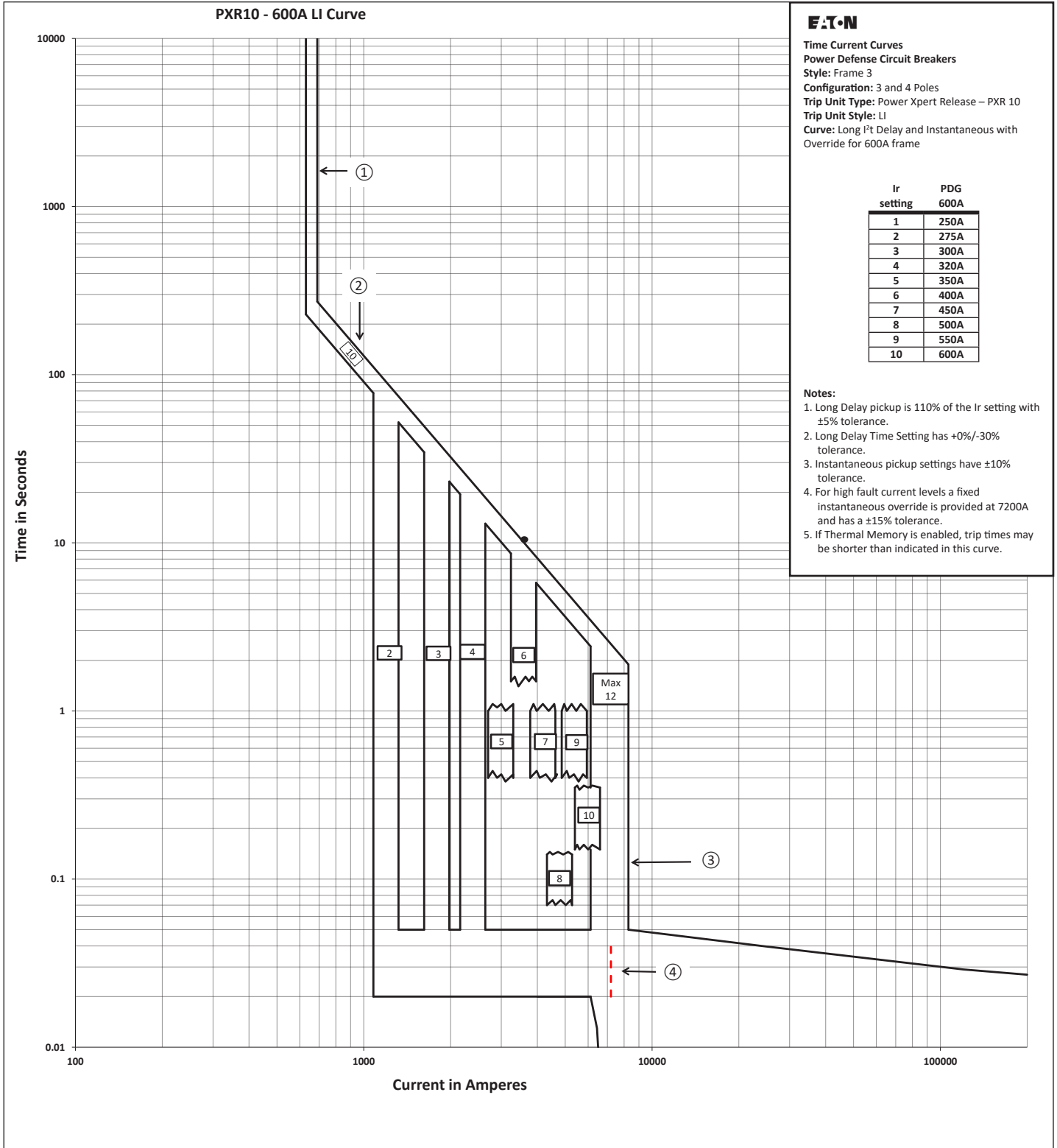

Figure 31. PXR 10 LI 600A frame.

November 2019

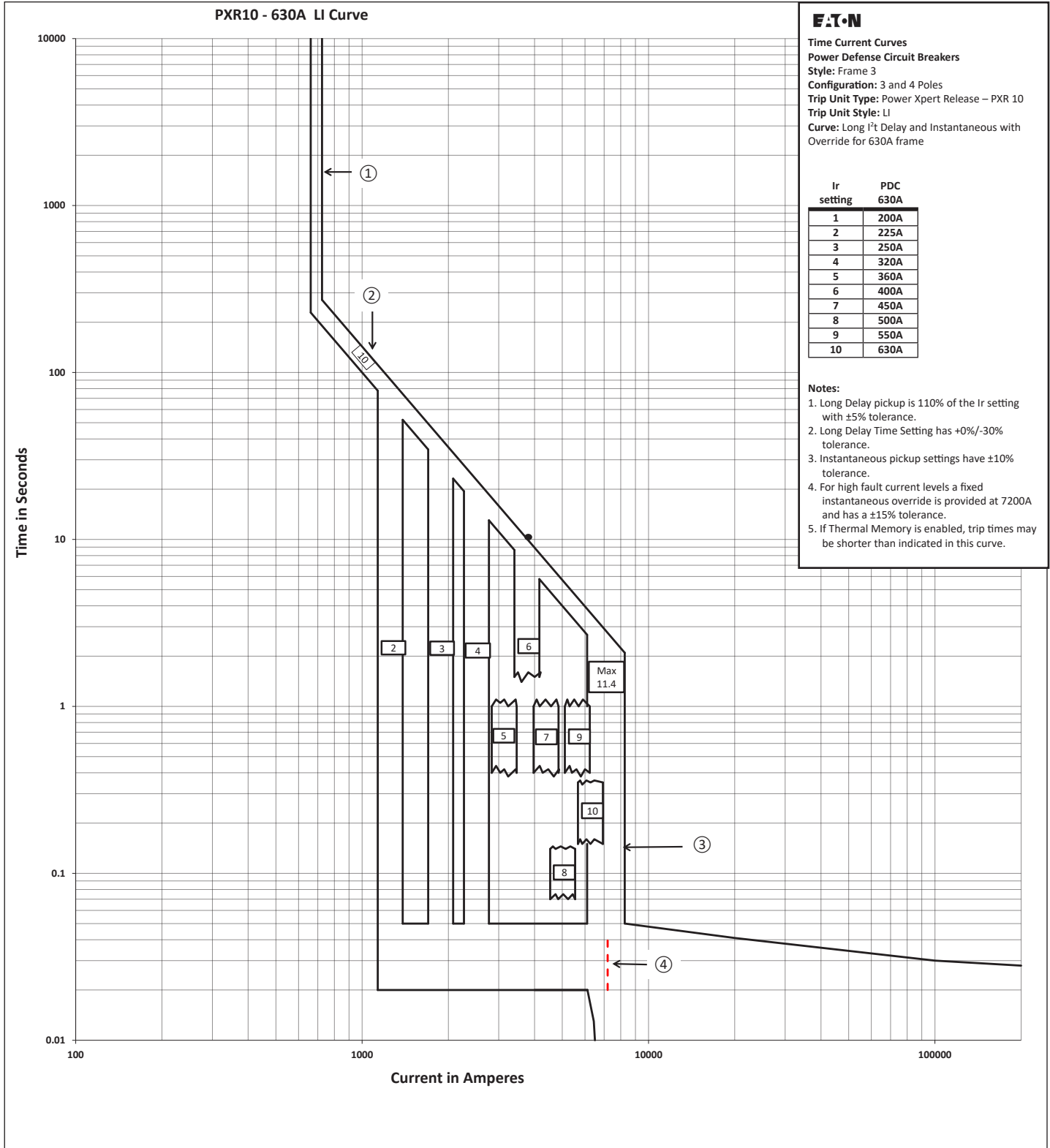

Figure 32. PXR 10 LI 630A frame.

November 2019

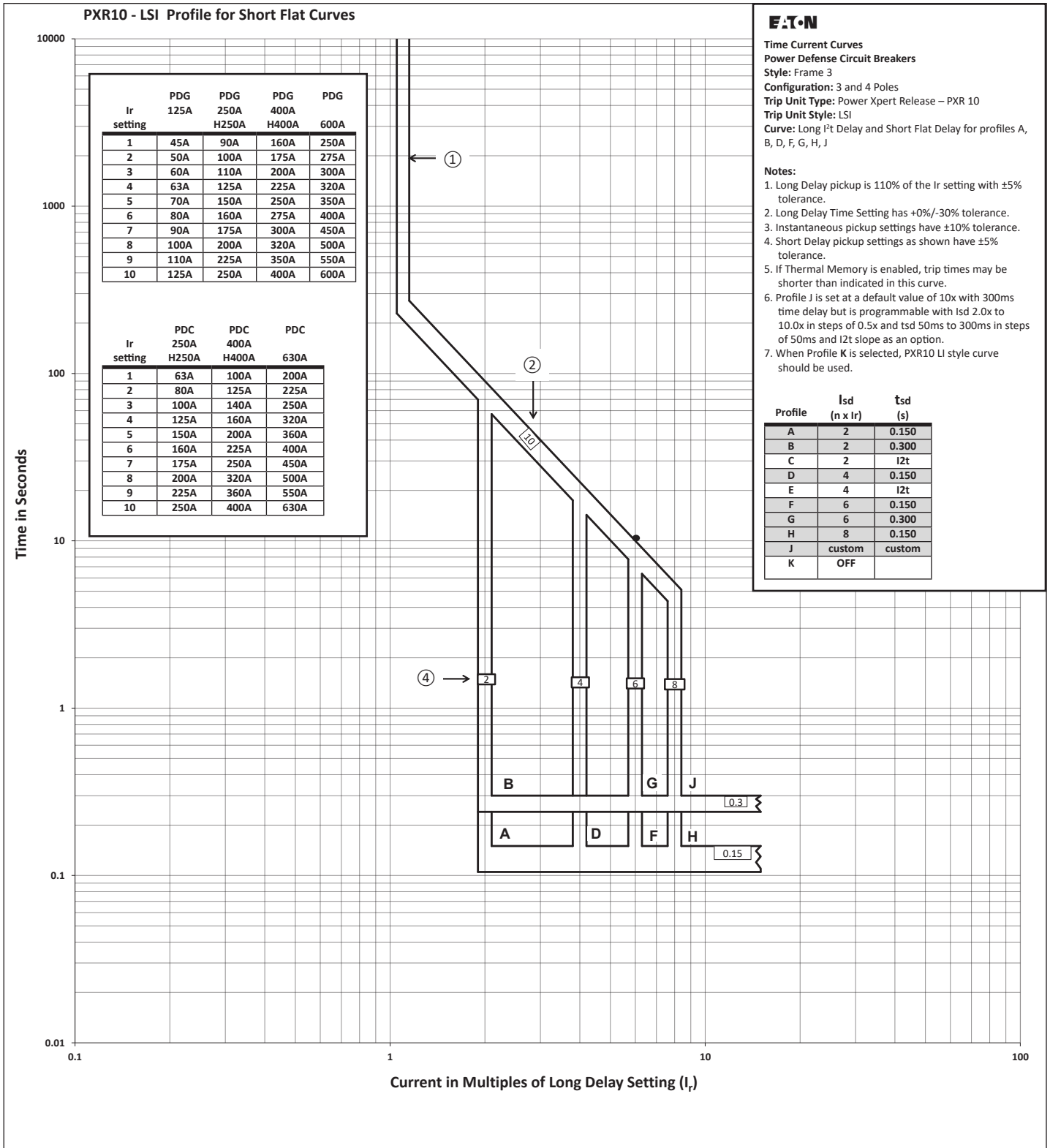

Figure 33. PXR 10 LSI profile for short flat curves.

November 2019

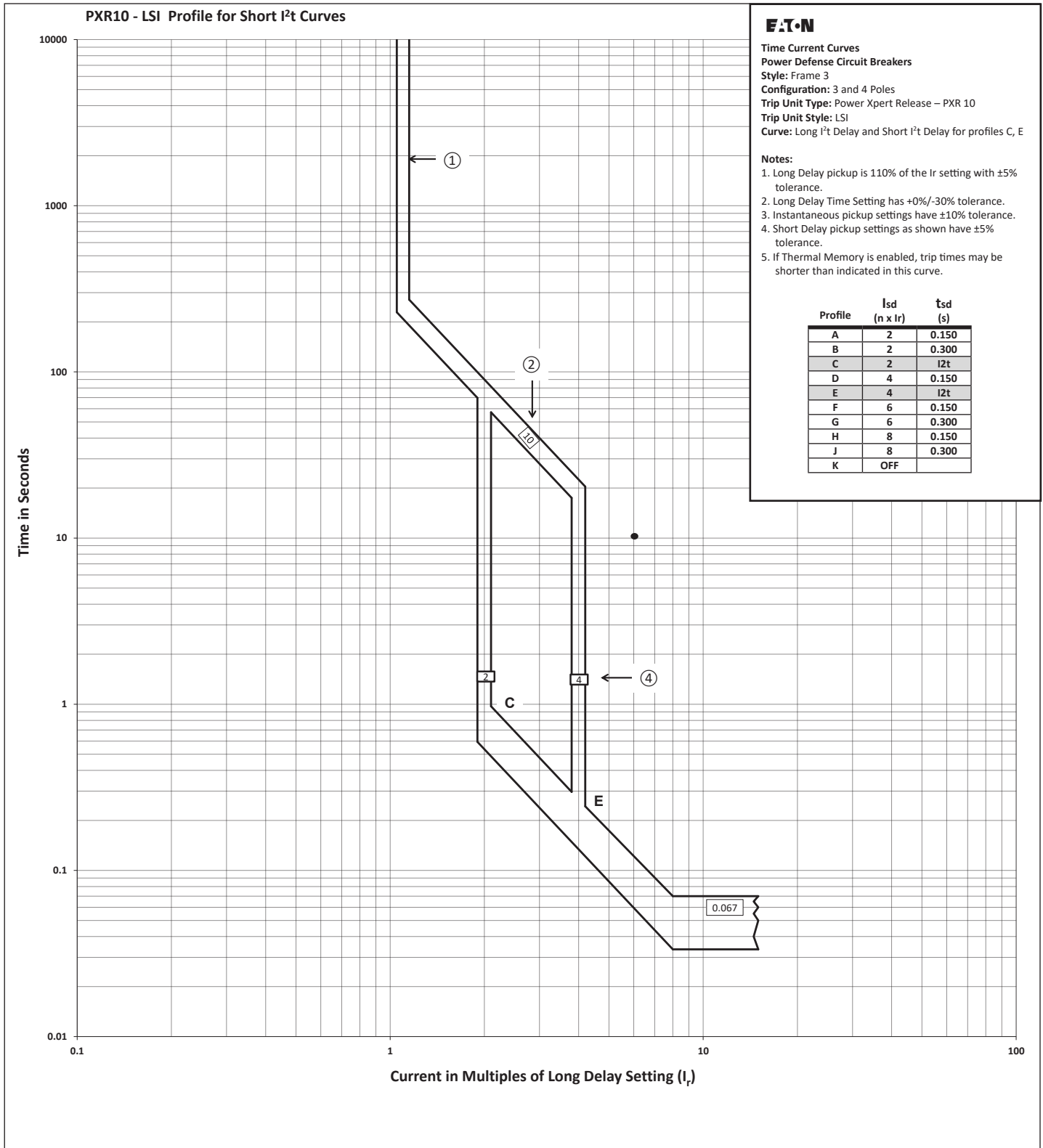

Figure 34. PXR 10 LSI profile for I²t short curves.

November 2019

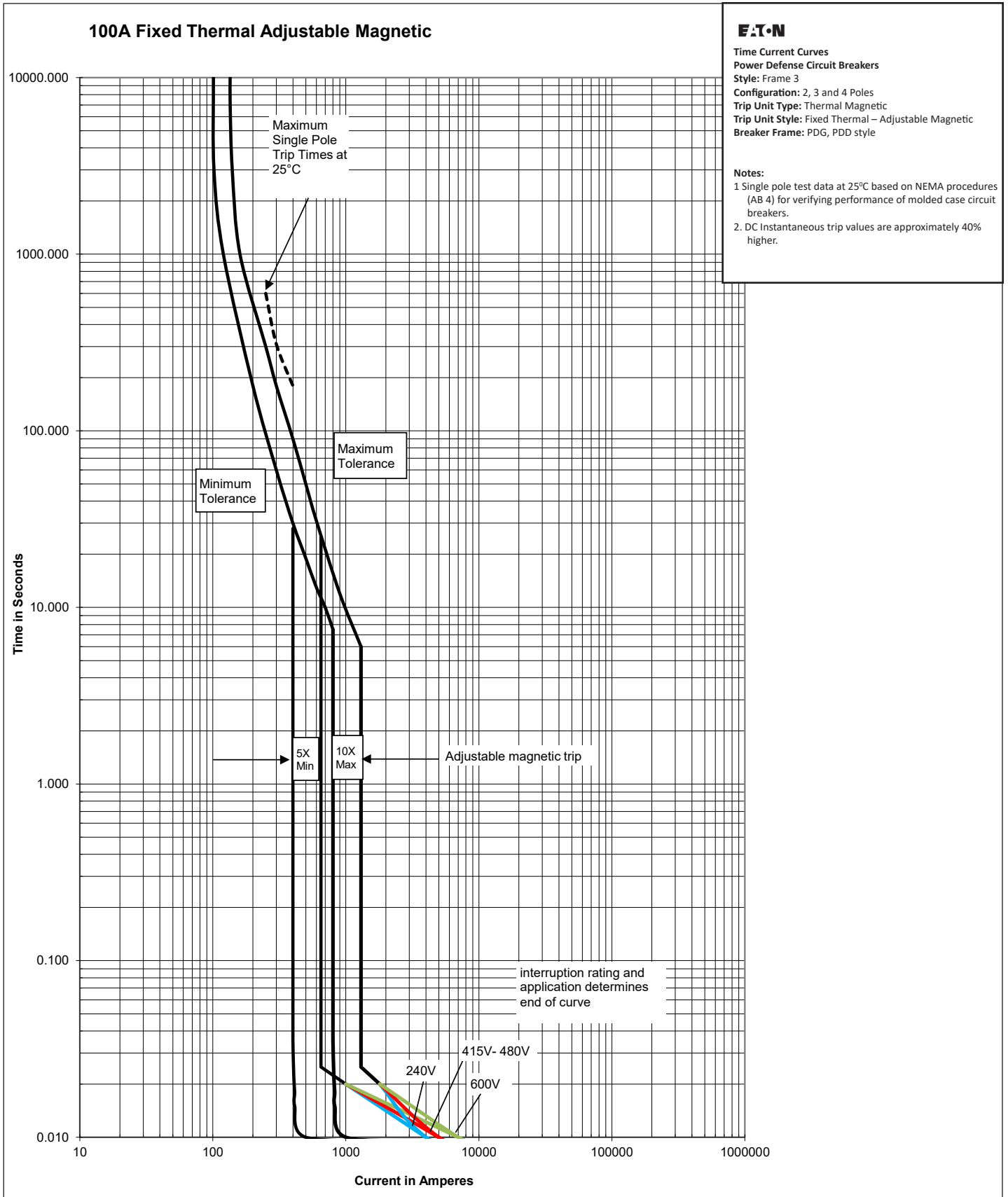

Figure 35. 100A fixed thermal adjustable magnetic.

November 2019

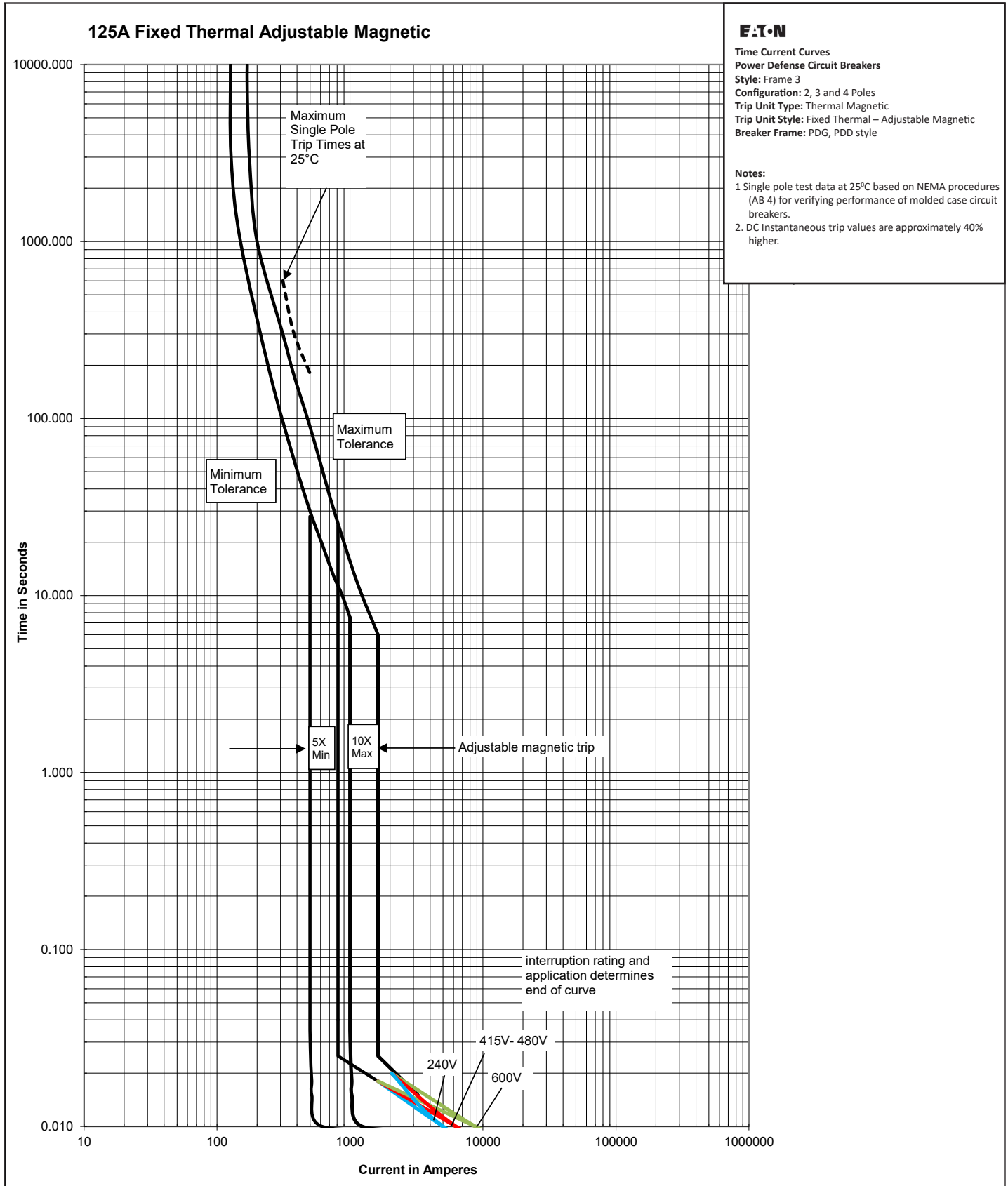

Figure 36. 125A fixed thermal adjustable magnetic.

November 2019

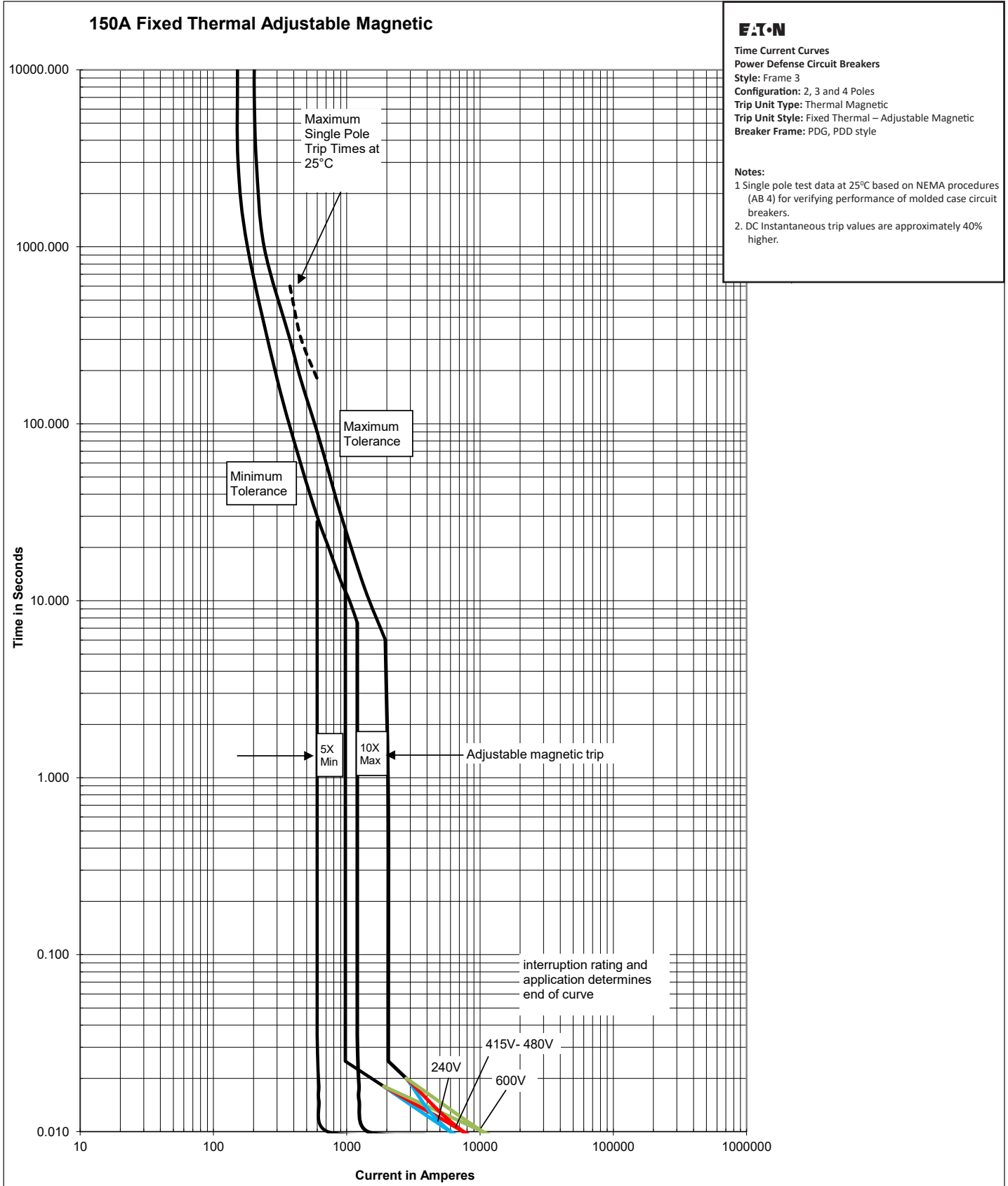

Figure 37. 150A fixed thermal adjustable magnetic.

November 2019

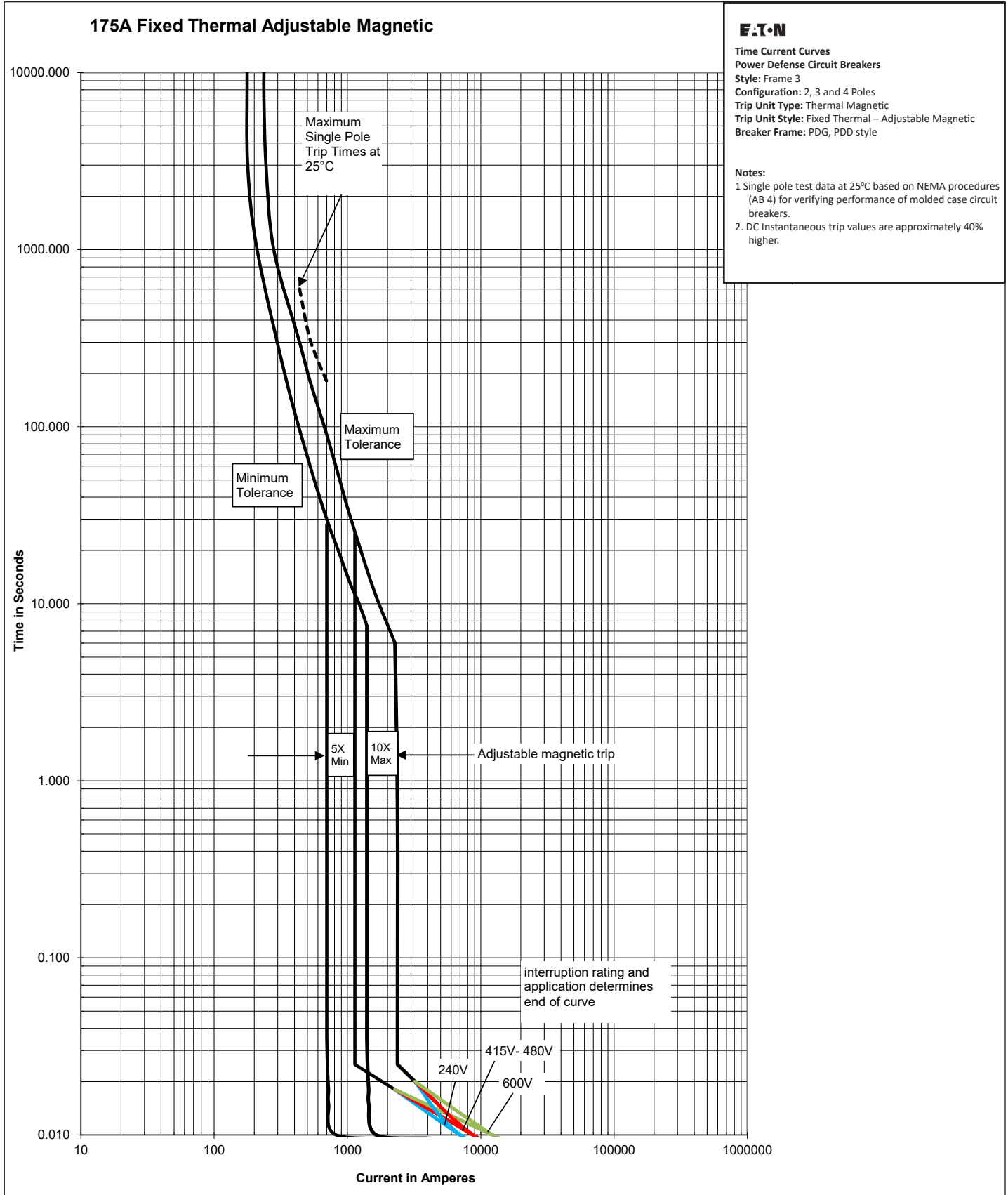

Figure 38. 175A fixed thermal adjustable magnetic.

November 2019

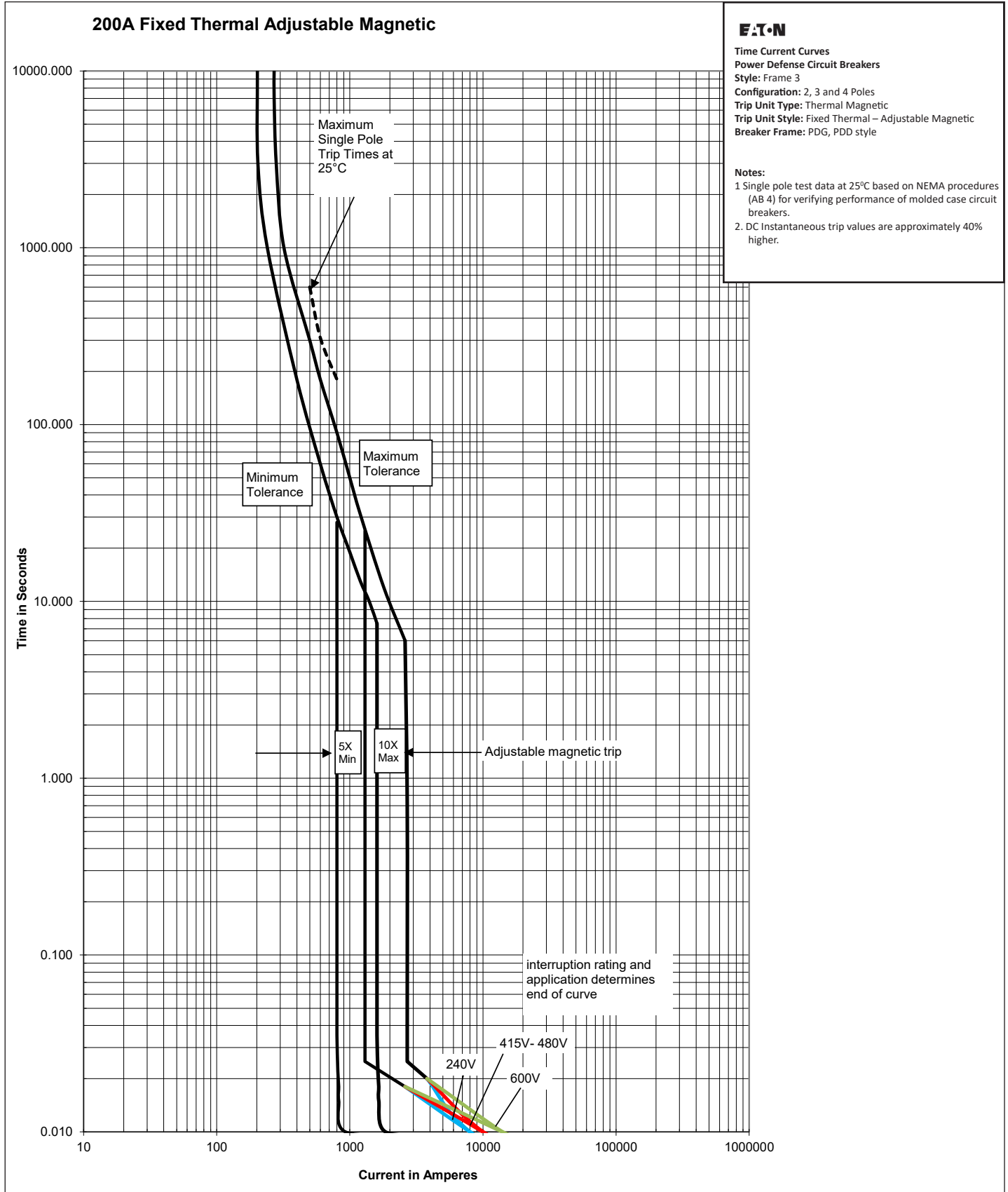

Figure 39. 200A fixed thermal adjustable magnetic.

November 2019

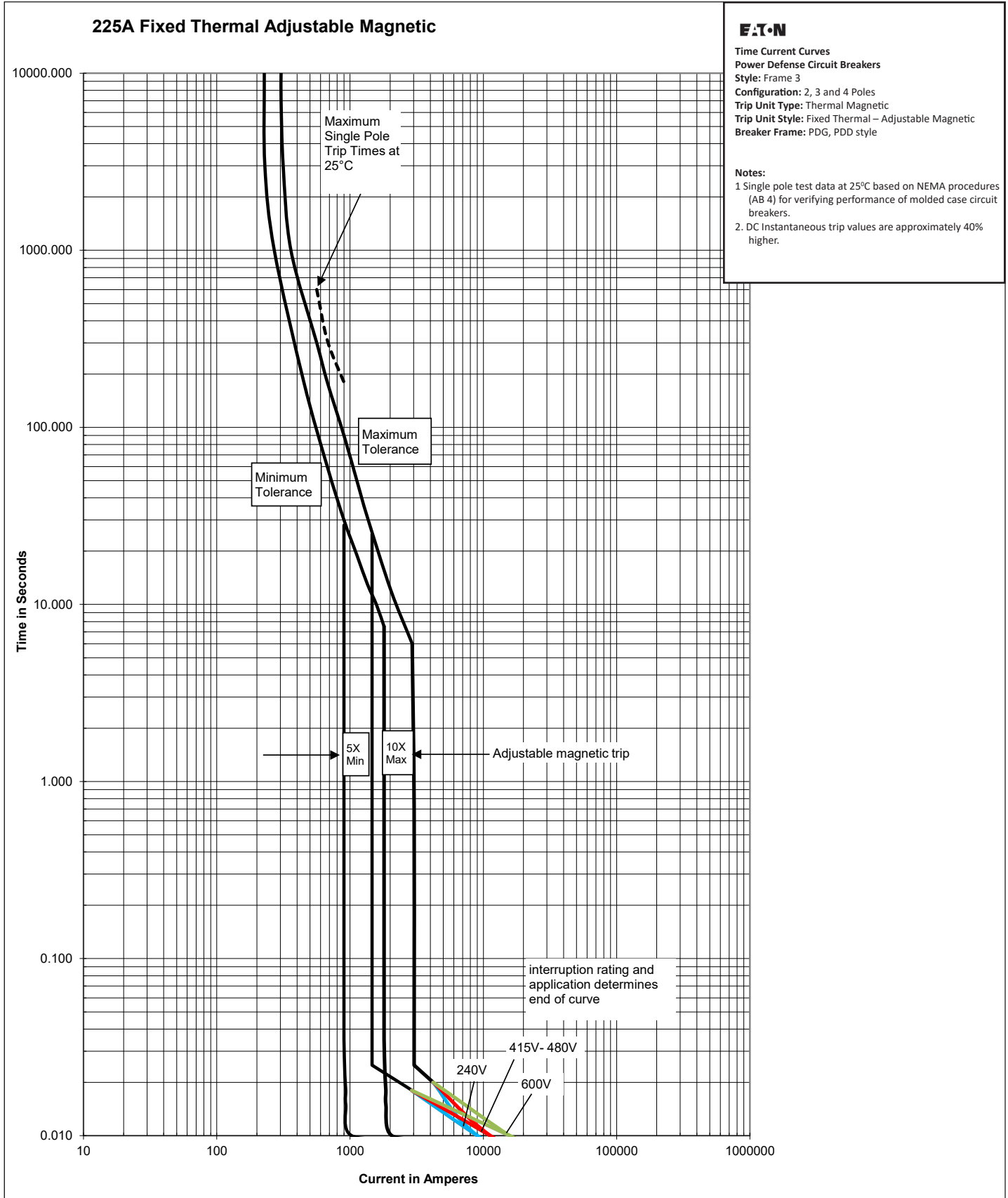

Figure 40. 225A fixed thermal adjustable magnetic.

November 2019

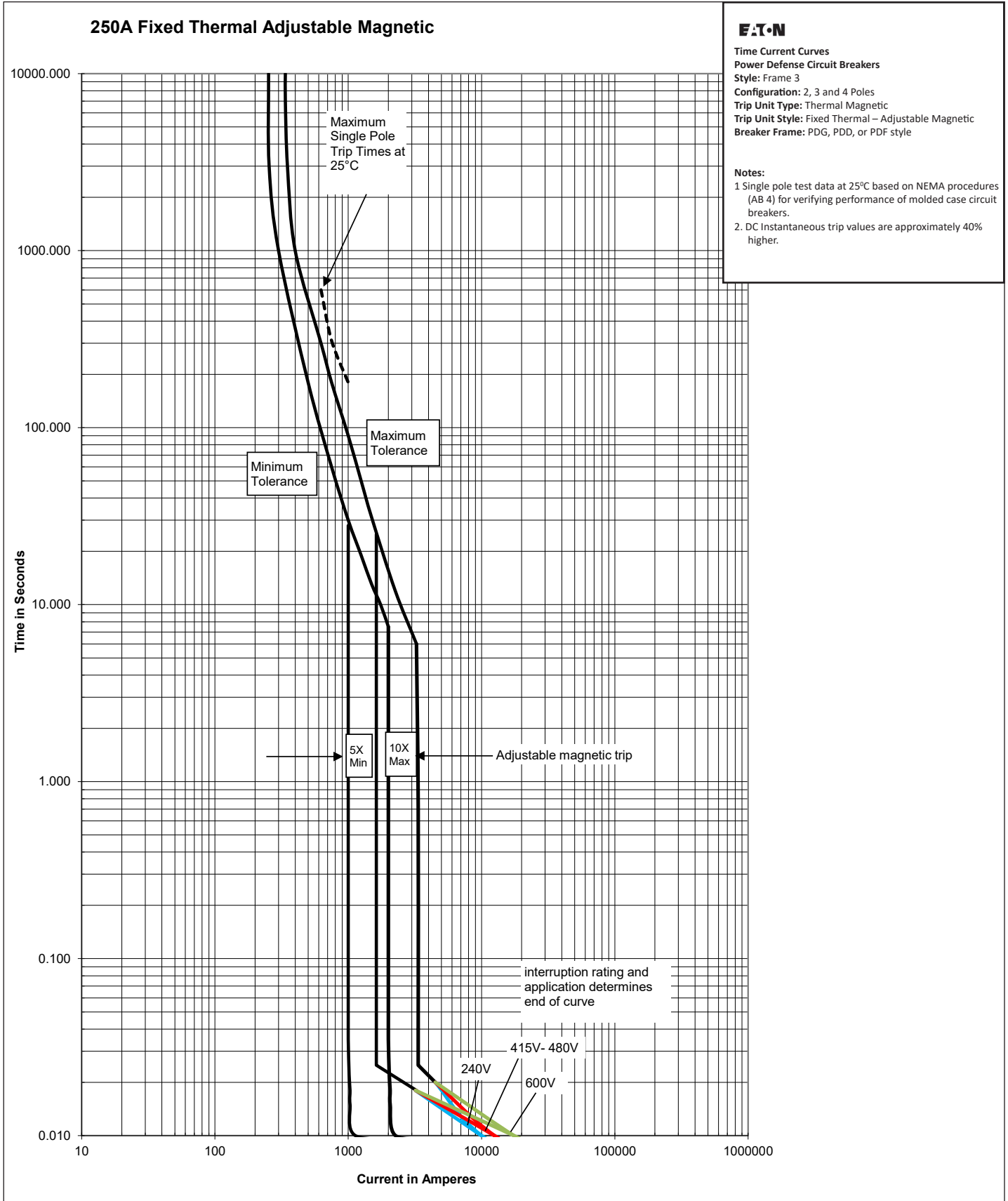

Figure 41. 250A fixed thermal adjustable magnetic.

November 2019

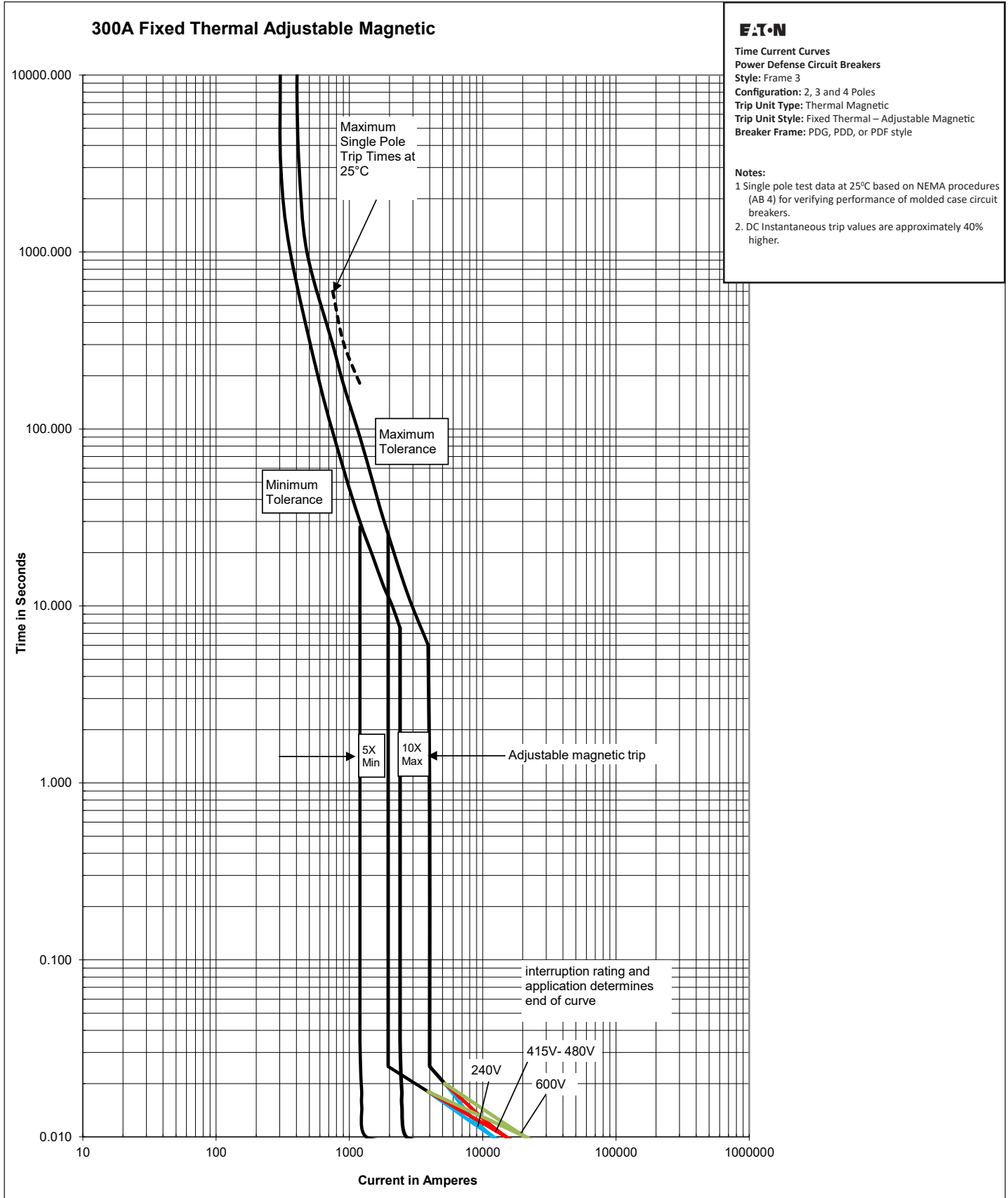

Figure 42. 300A fixed thermal adjustable magnetic.

November 2019

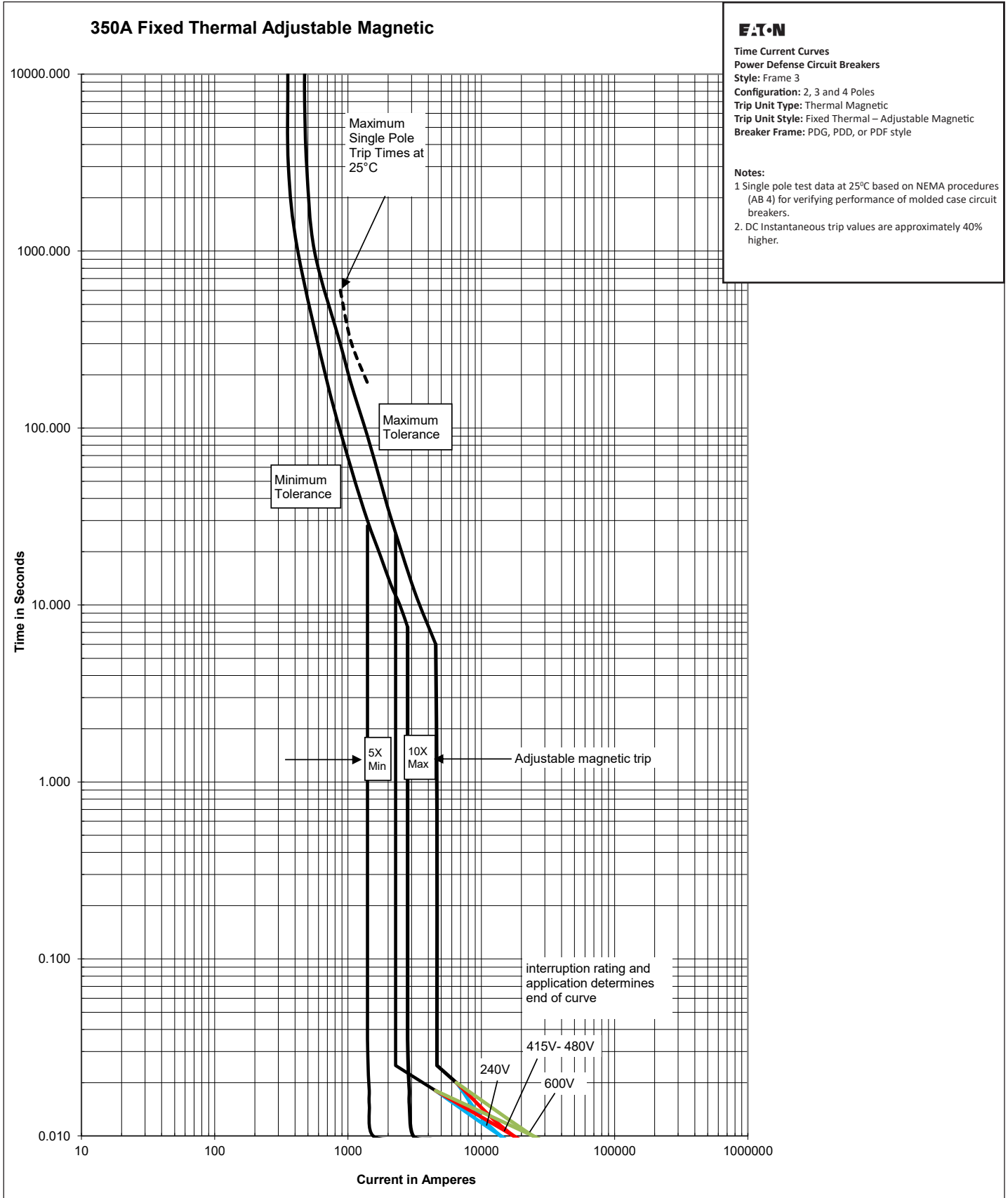

Figure 43. 350A fixed thermal adjustable magnetic.

November 2019

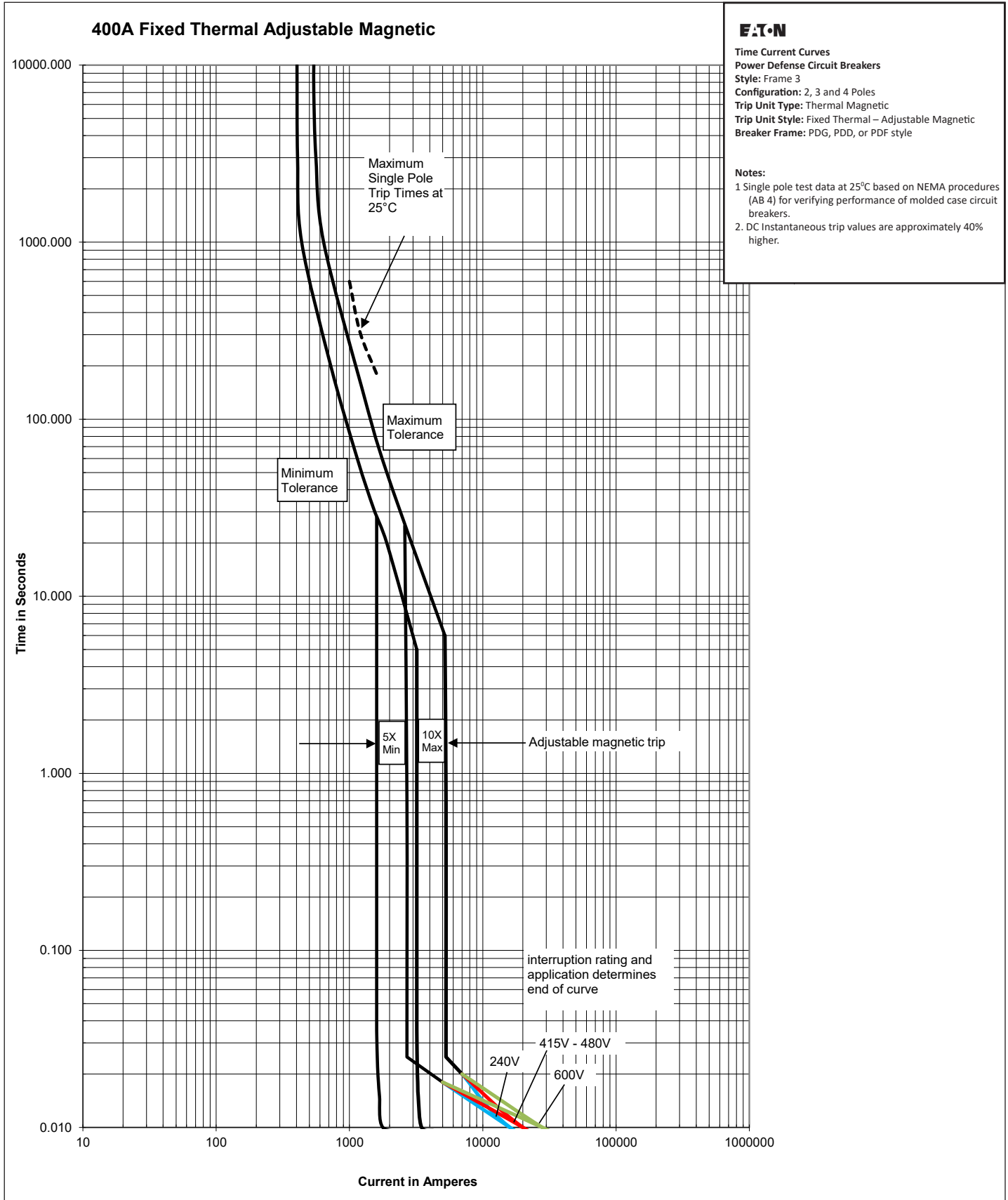

Figure 44. 400A fixed thermal adjustable magnetic.

November 2019

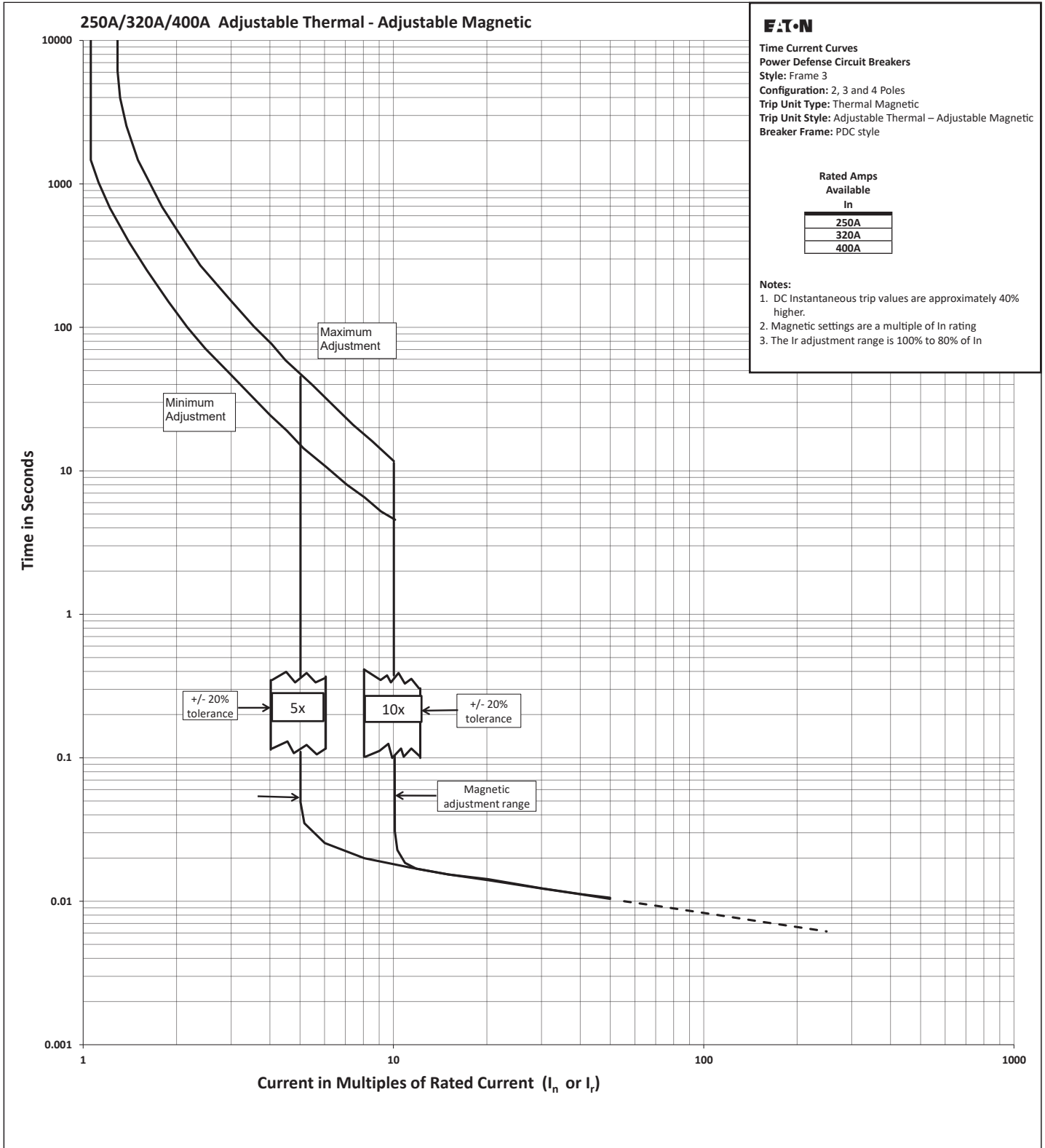

Figure 45. 250A/320A/400A adjustable thermal adjustable magnetic.

November 2019

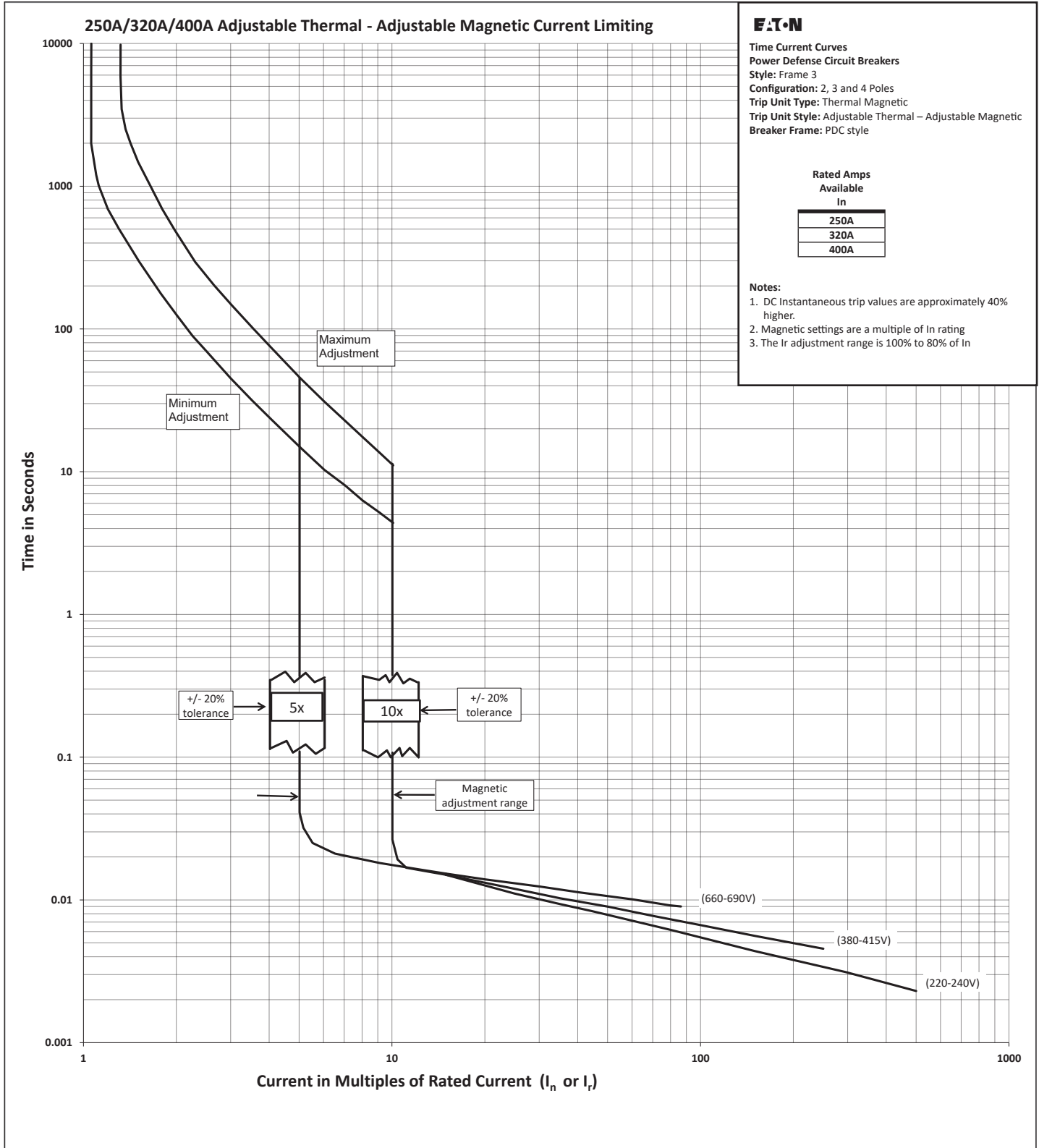

Figure 46. 250A/320A/400A adjustable thermal adjustable magnetic - current limiting.

November 2019

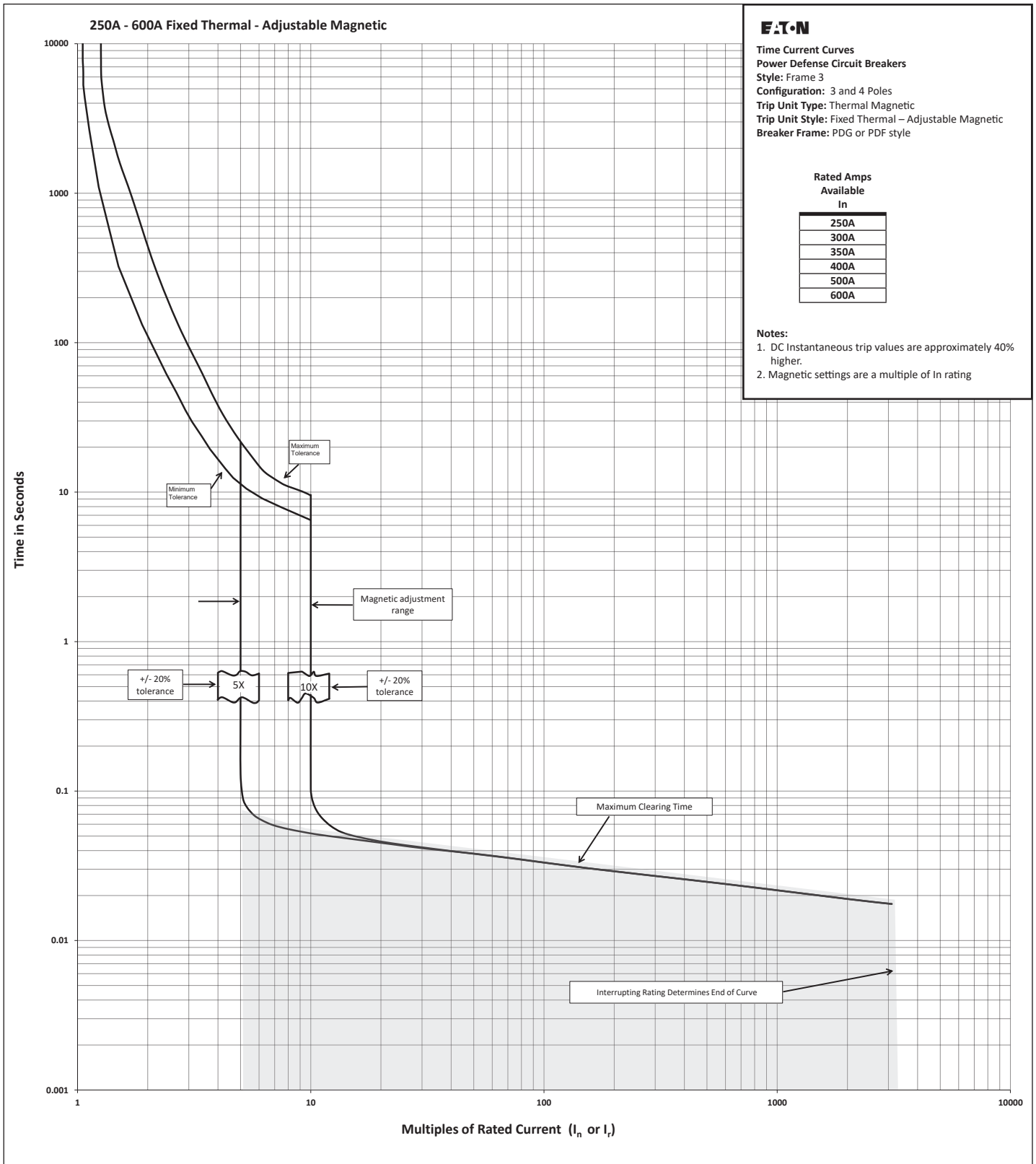

Figure 47. 250A – 600A fixed thermal adjustable magnetic.

November 2019

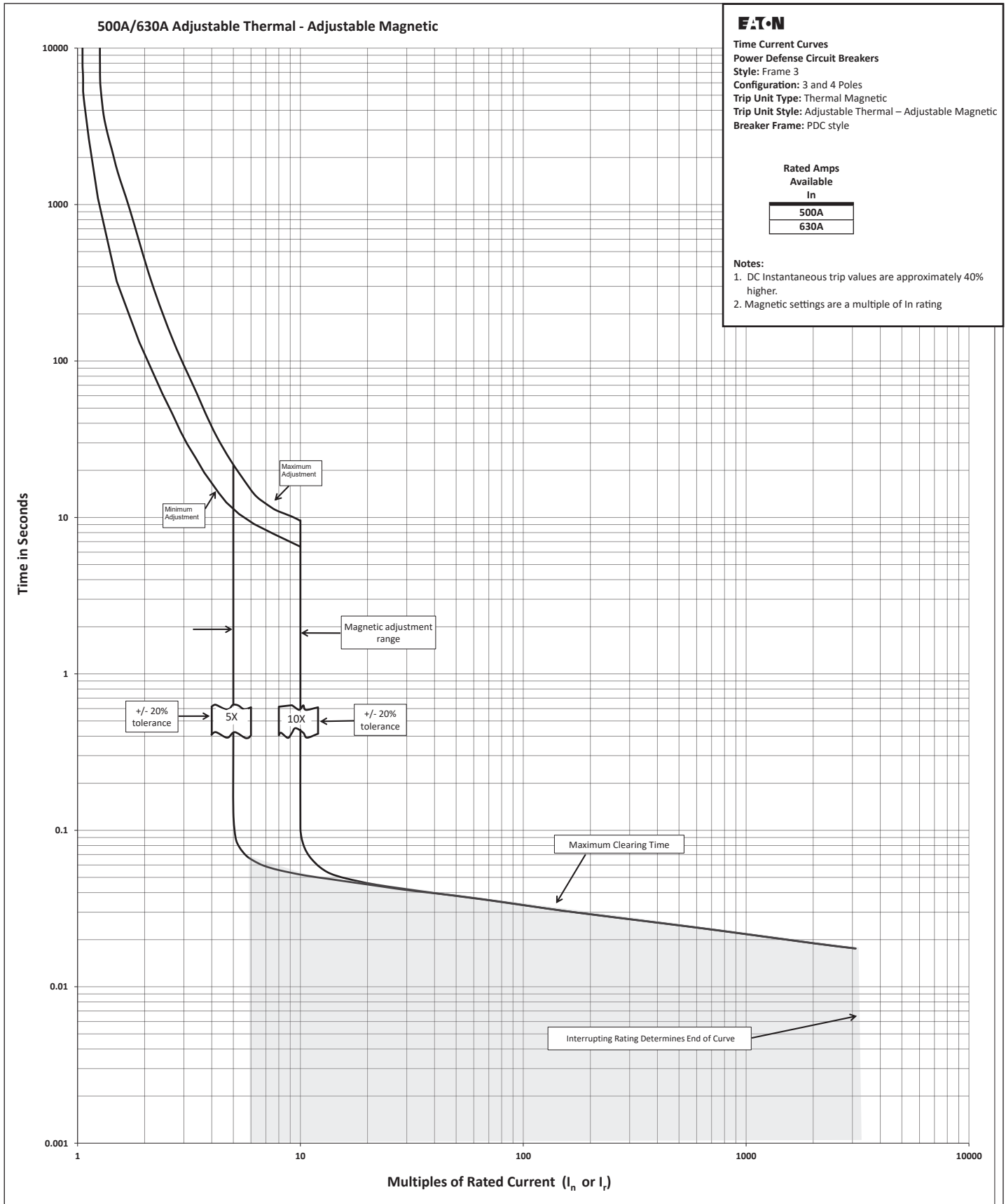

Figure 48. 500A/630A adjustable thermal adjustable magnetic.

November 2019

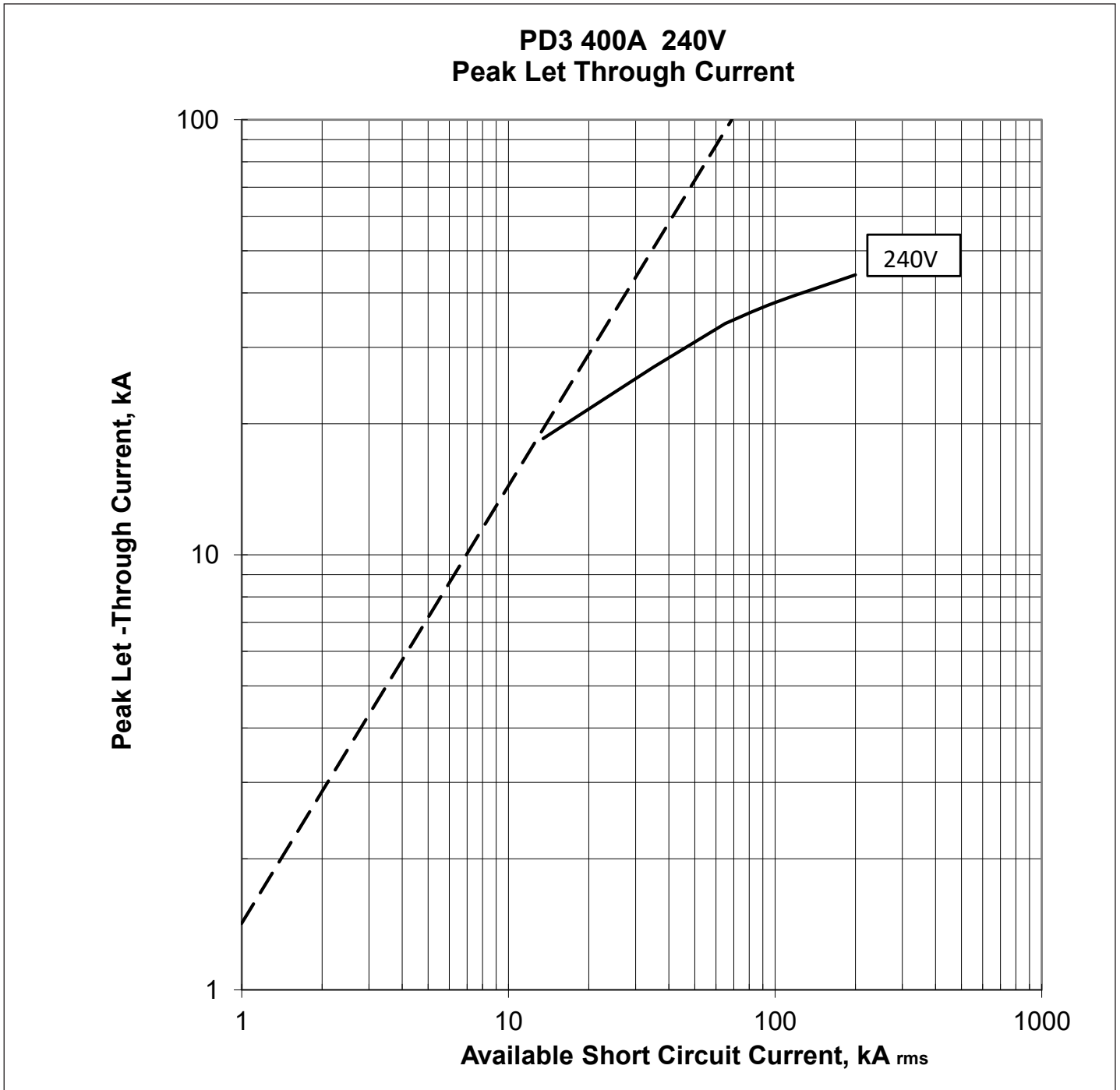

Figure 49. Peak let through current 400A @ 240V.

November 2019

PD3 400A 240V
Peak Let Through Energy

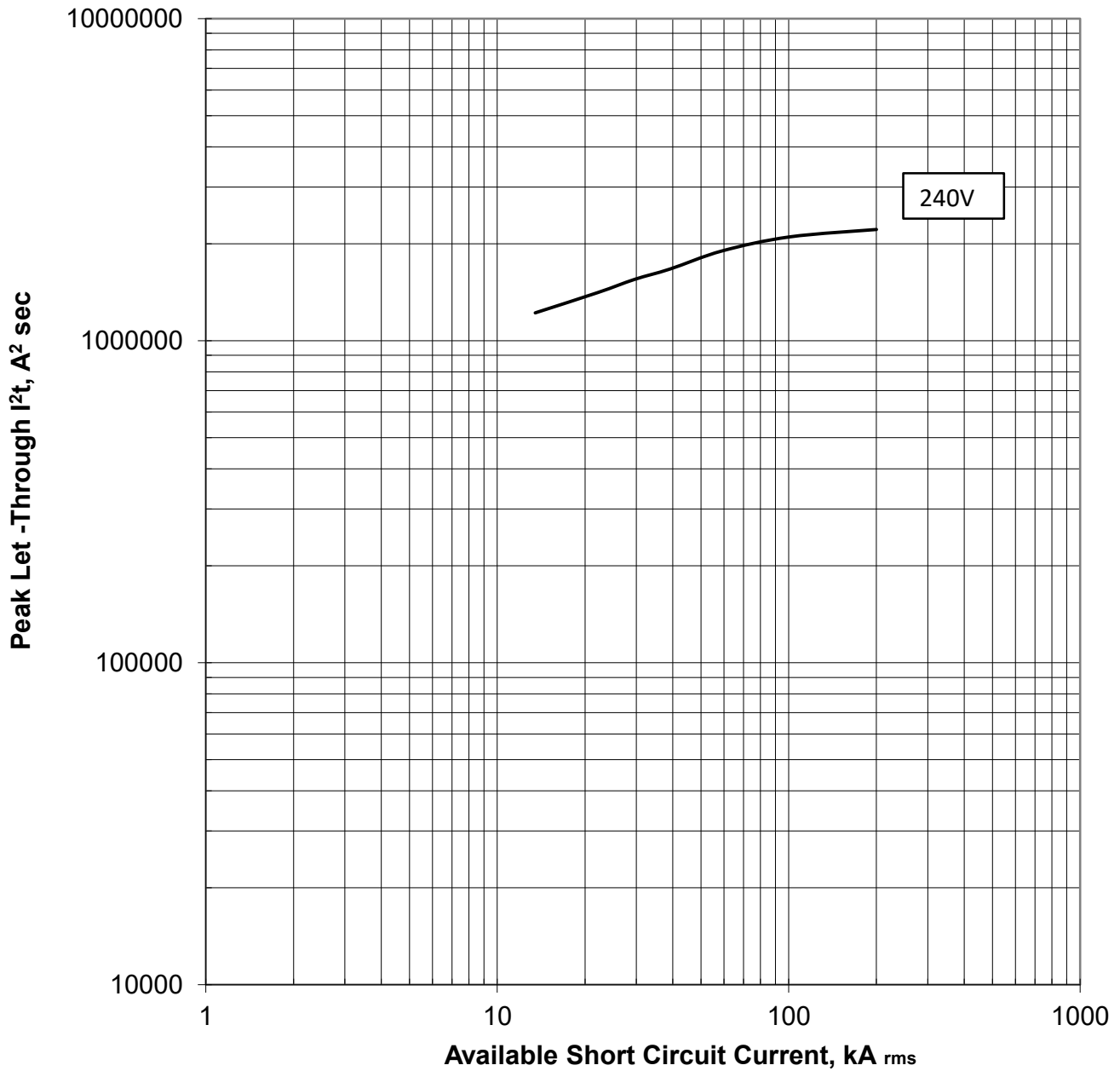

Figure 50. Peak let through energy 400A @ 240V.

November 2019

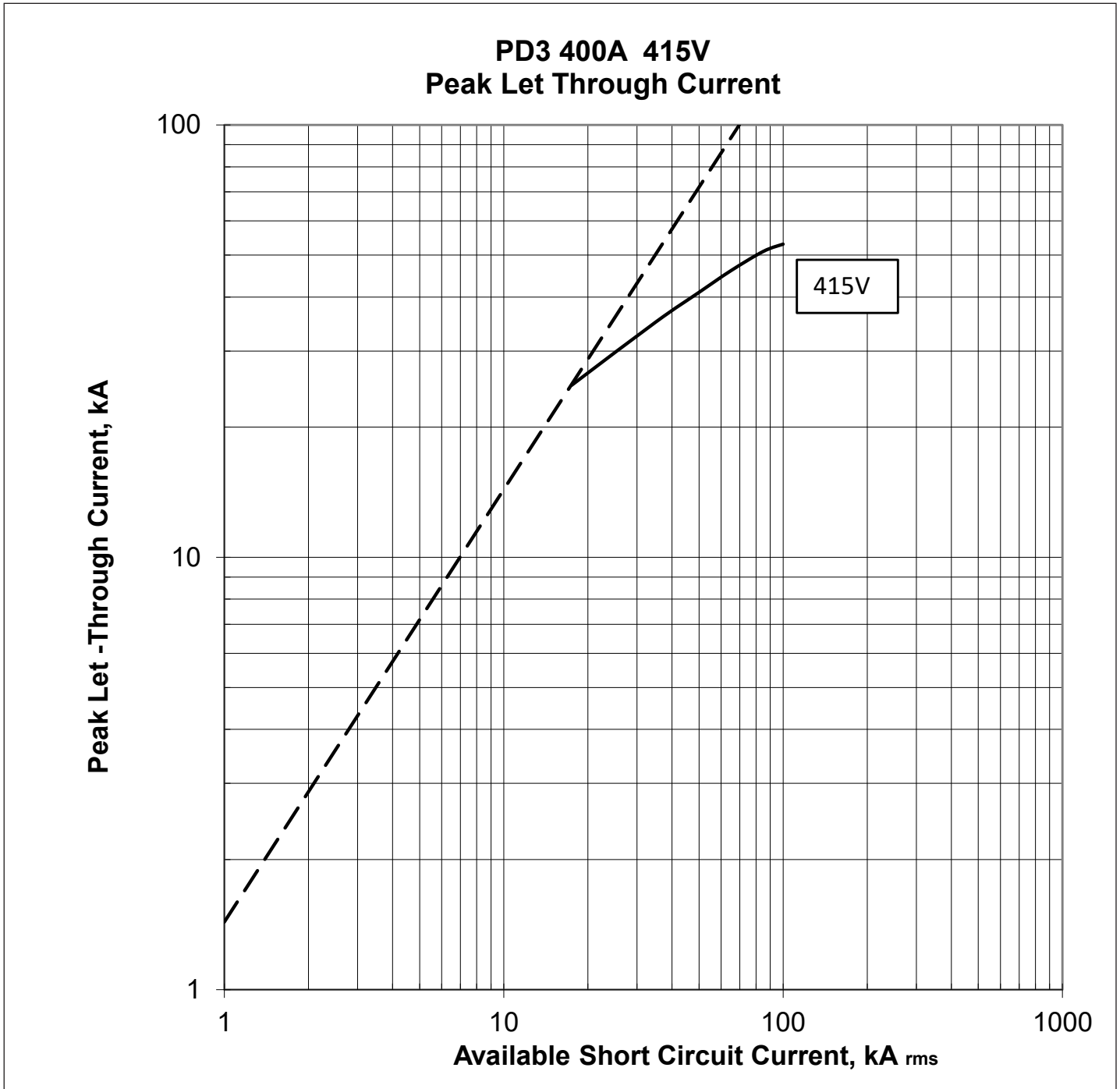

Figure 51. Peak let through current 400A @ 415V.

November 2019

PD3 400A 415V
Peak Let Through Energy

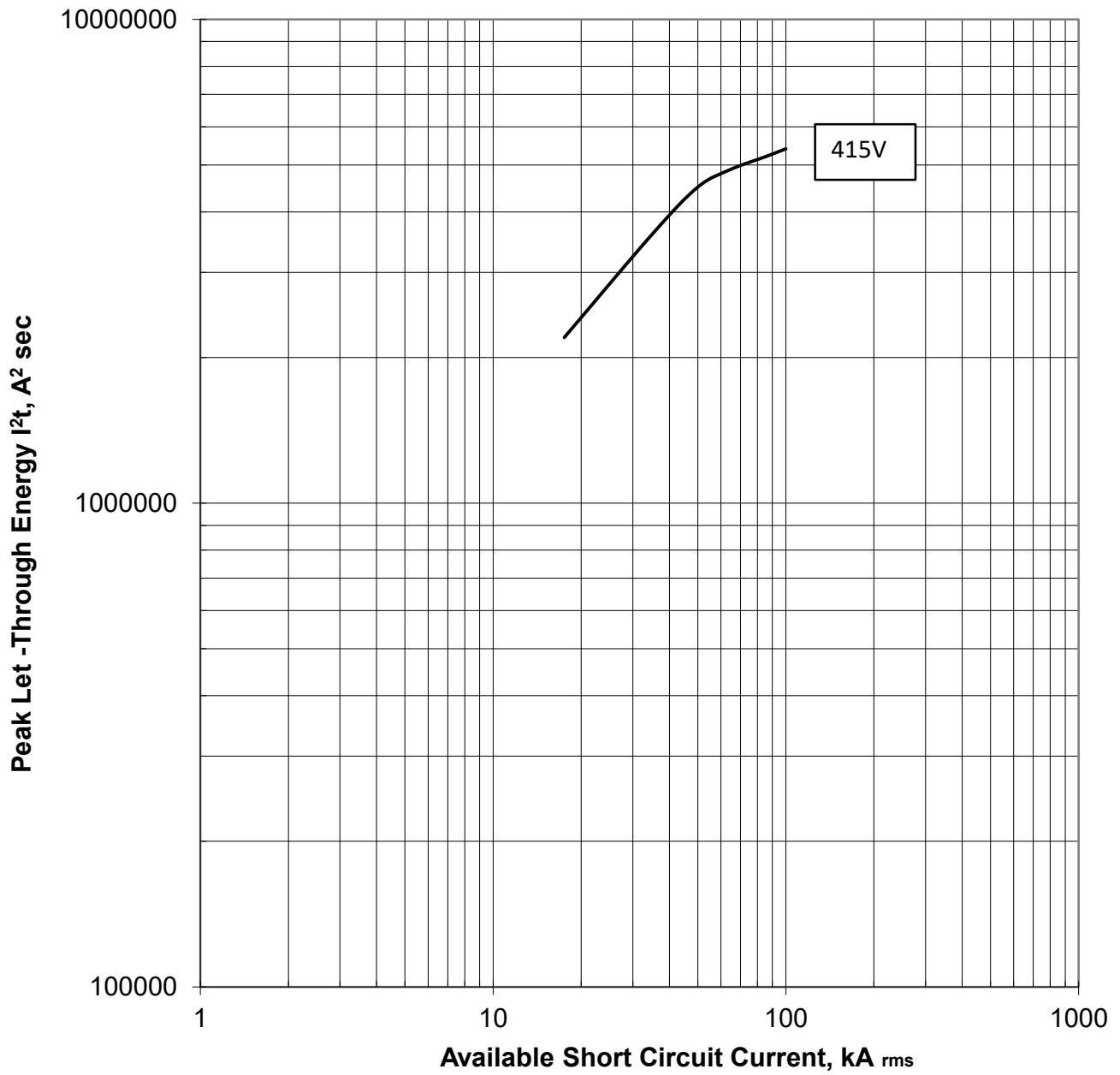

Figure 52. Peak let through energy 400A @ 415V.

November 2019

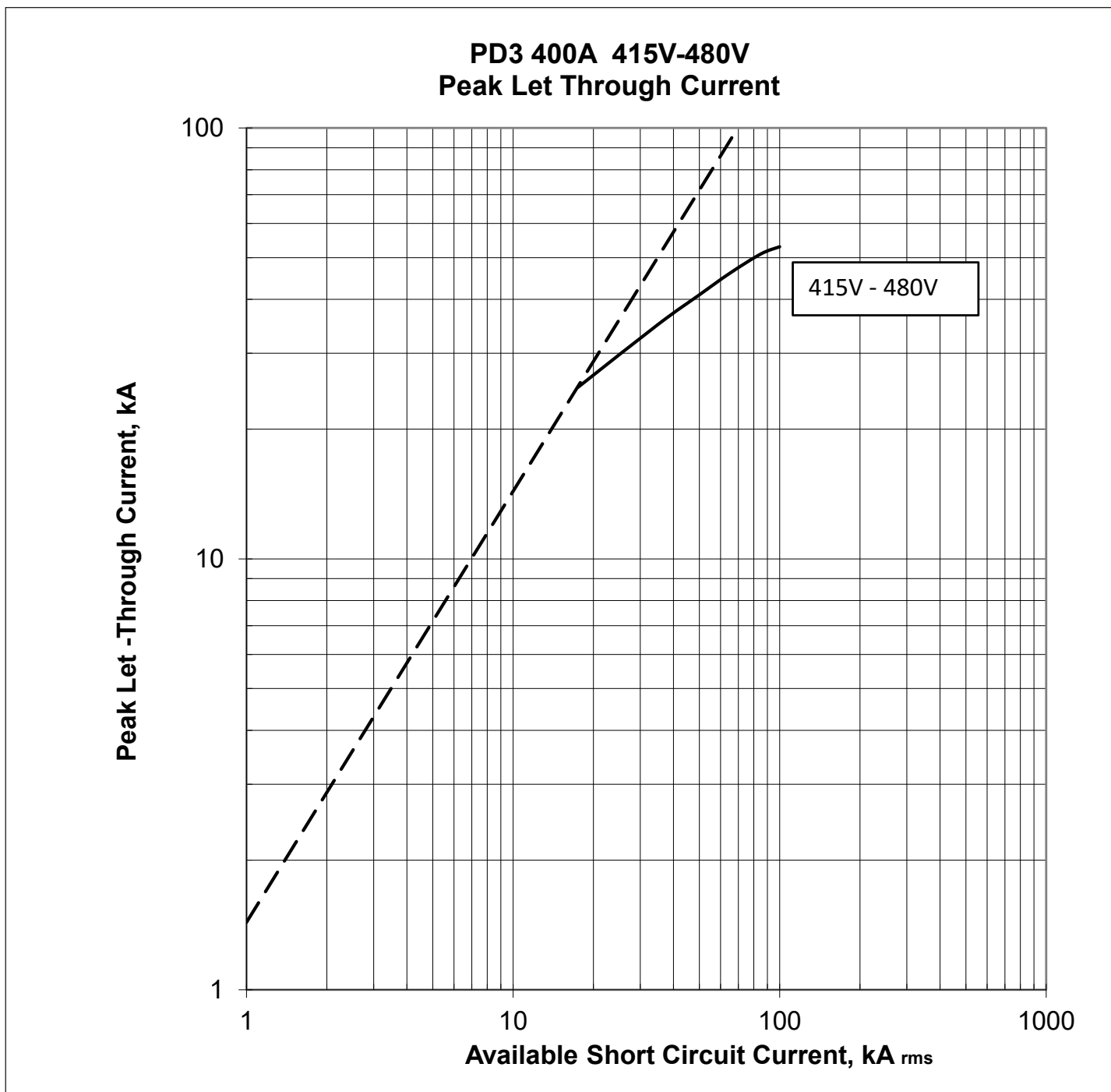

Figure 53. Peak let through current 400A @ 415V-480V.

November 2019

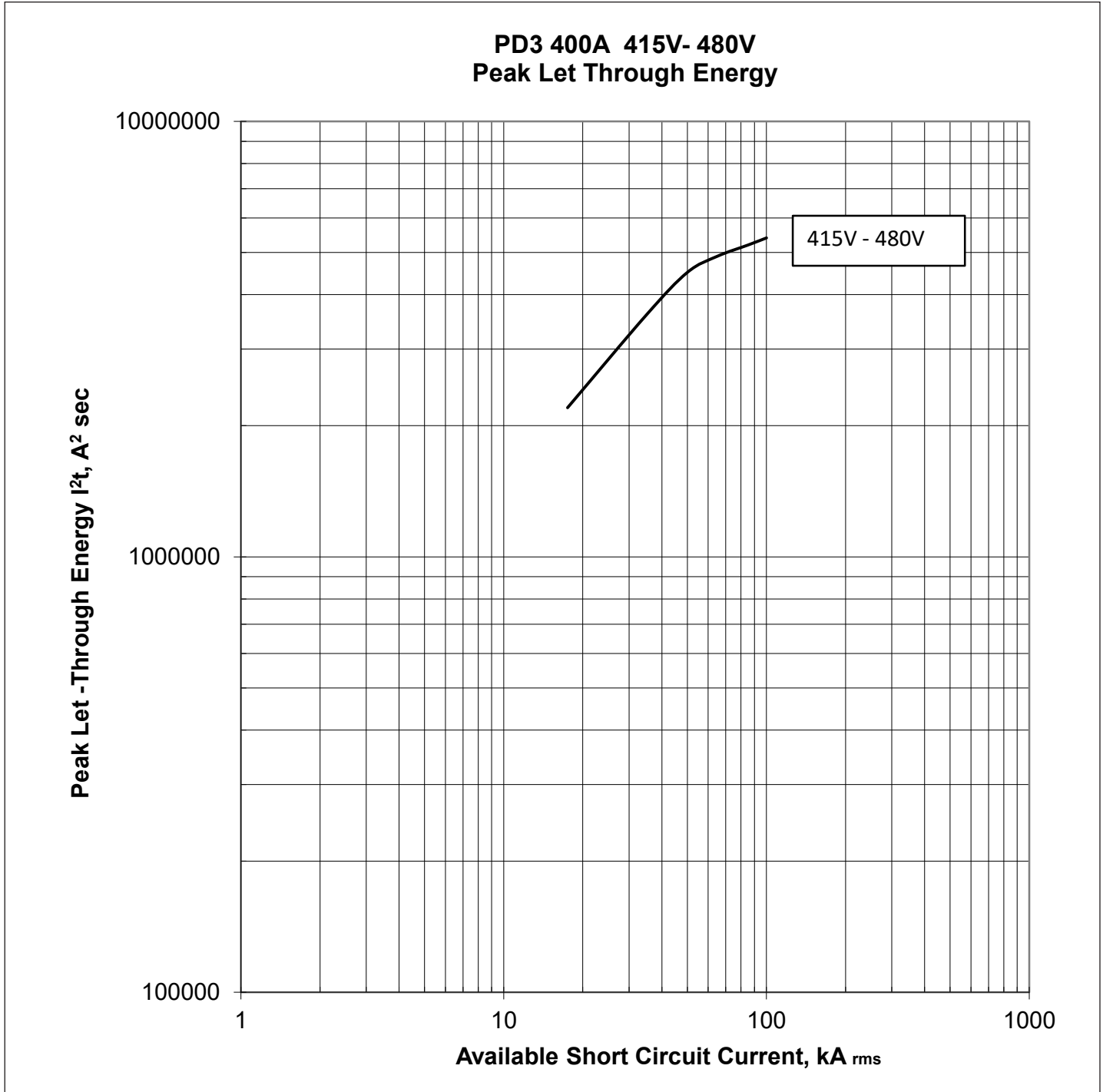

Figure 54. Peak let through energy 400A @ 415V-480V.

November 2019

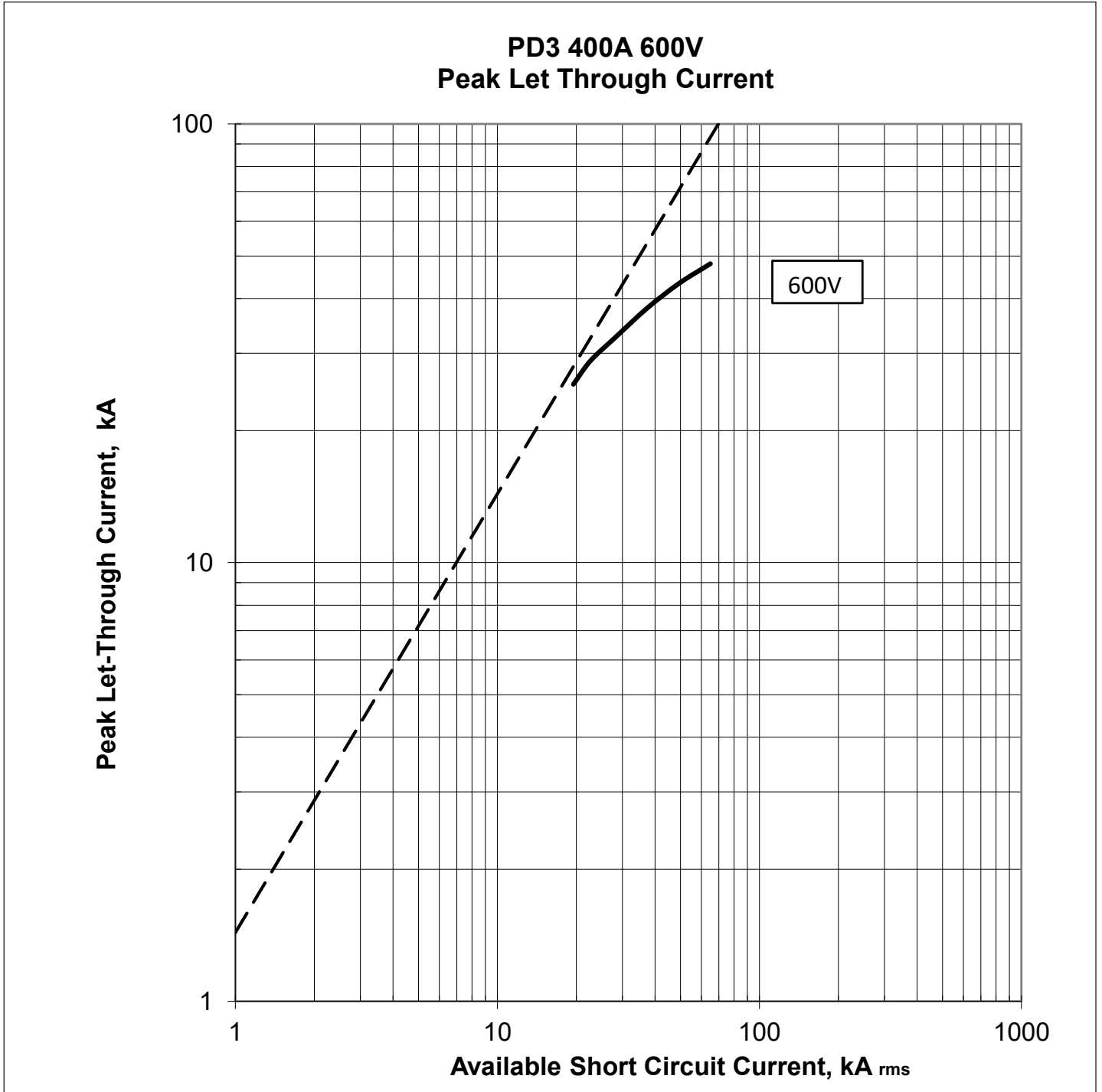

Figure 55. Peak let through current 400A @ 600V.

November 2019

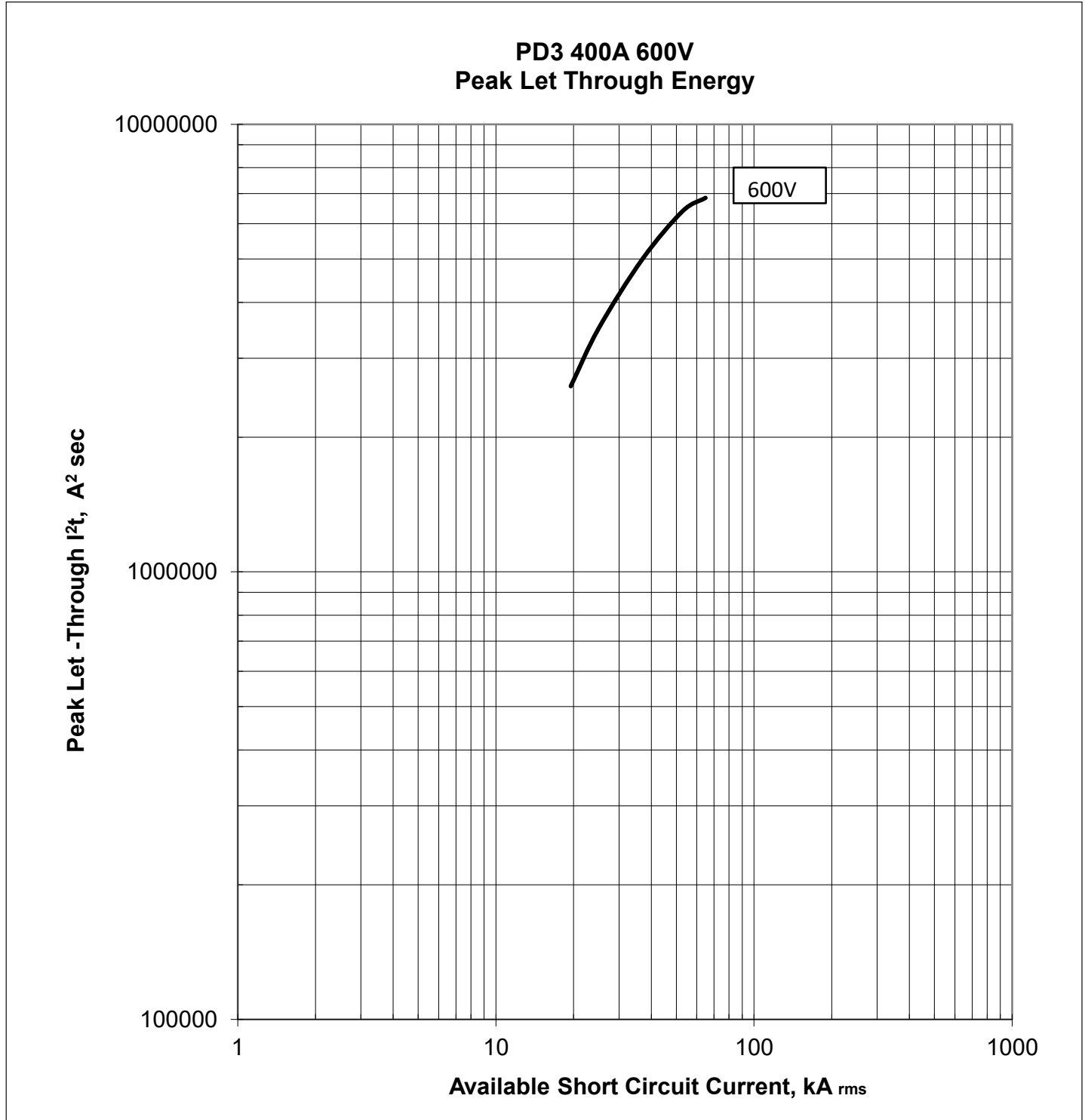

Figure 56. Peak let through energy 400A @ 600V

November 2019.

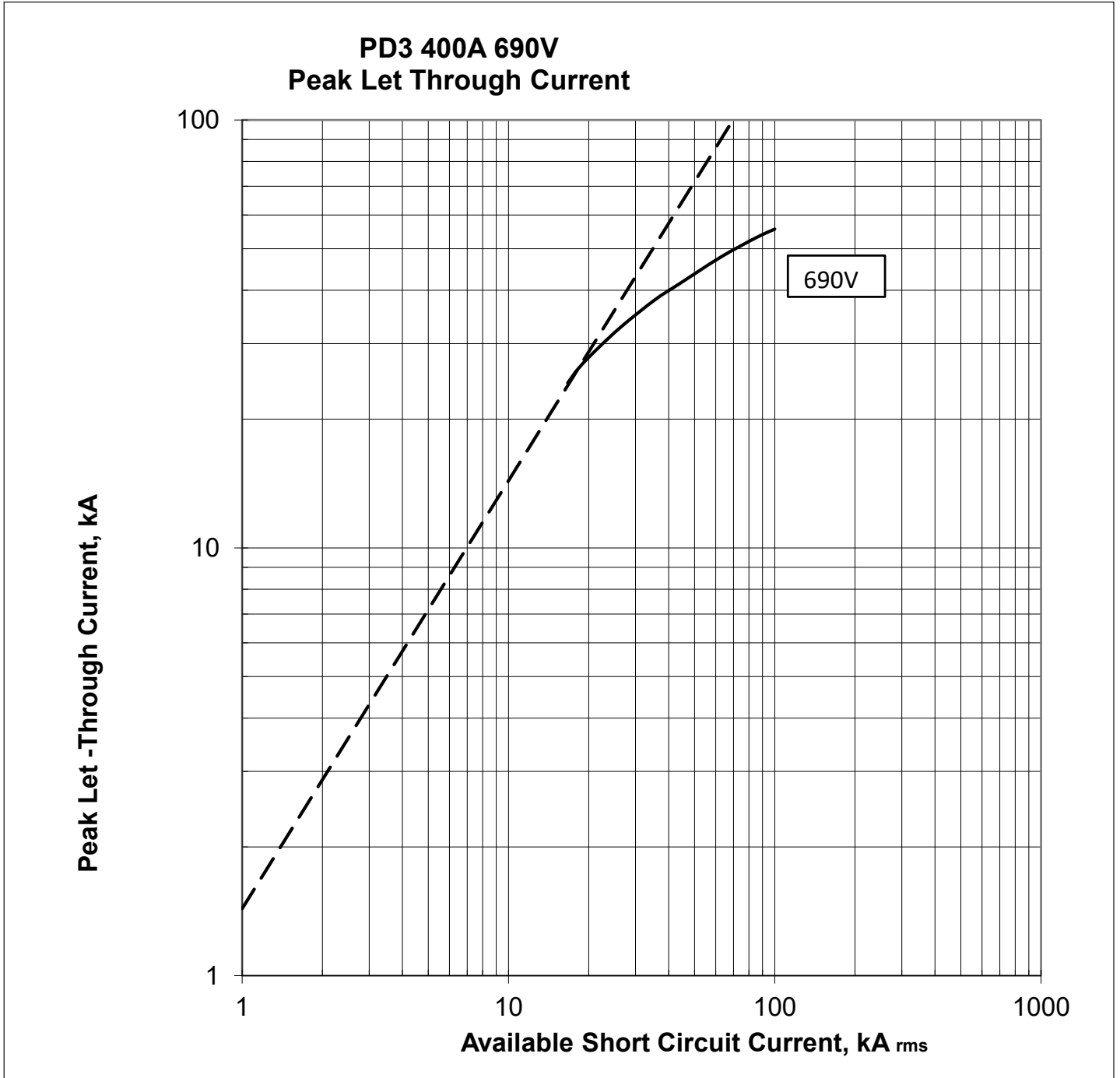

Figure 57. Peak let through current 400A @ 690V.

November 2019

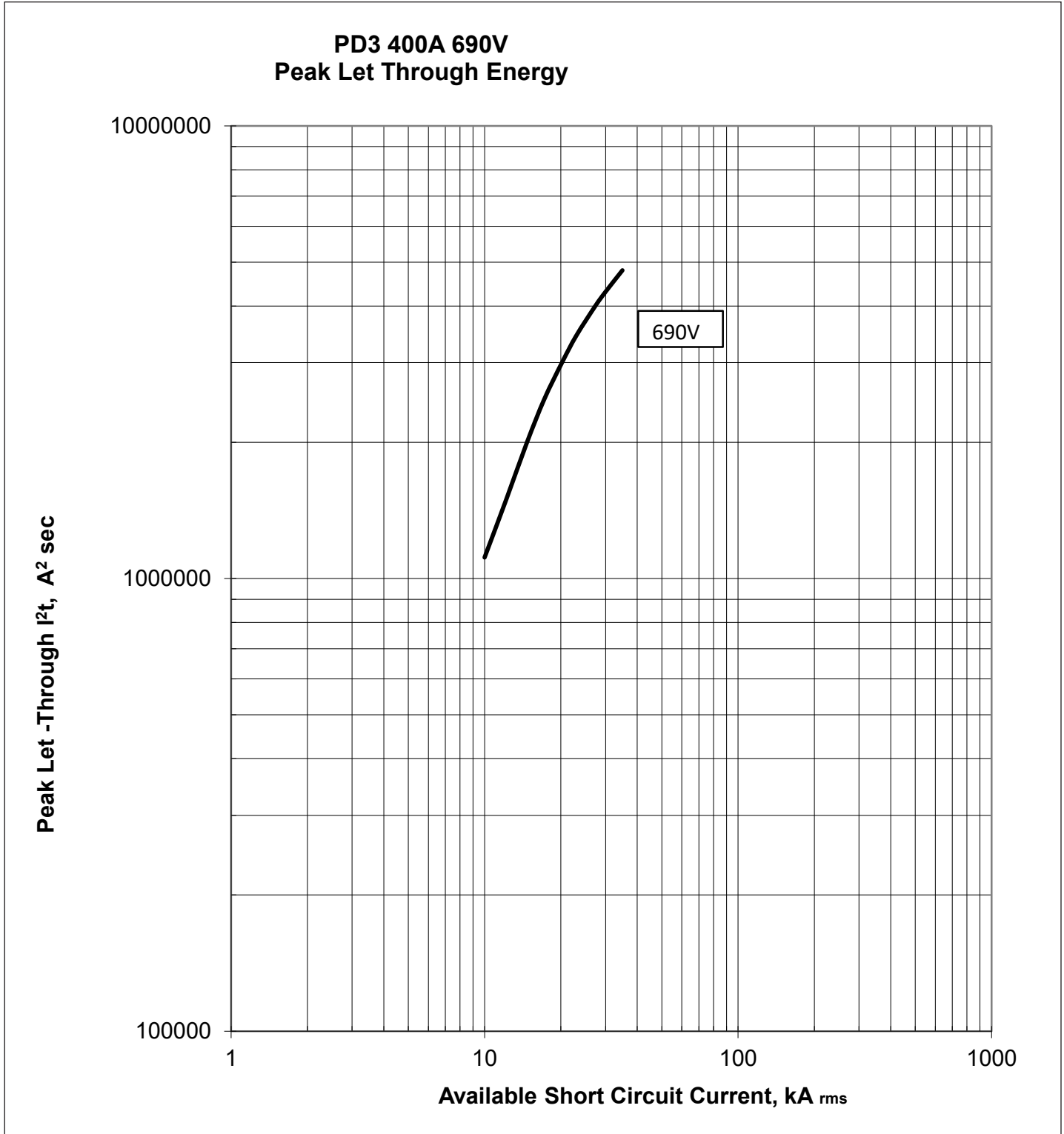

Figure 58. Peak let through energy 400A @ 690V.

November 2019

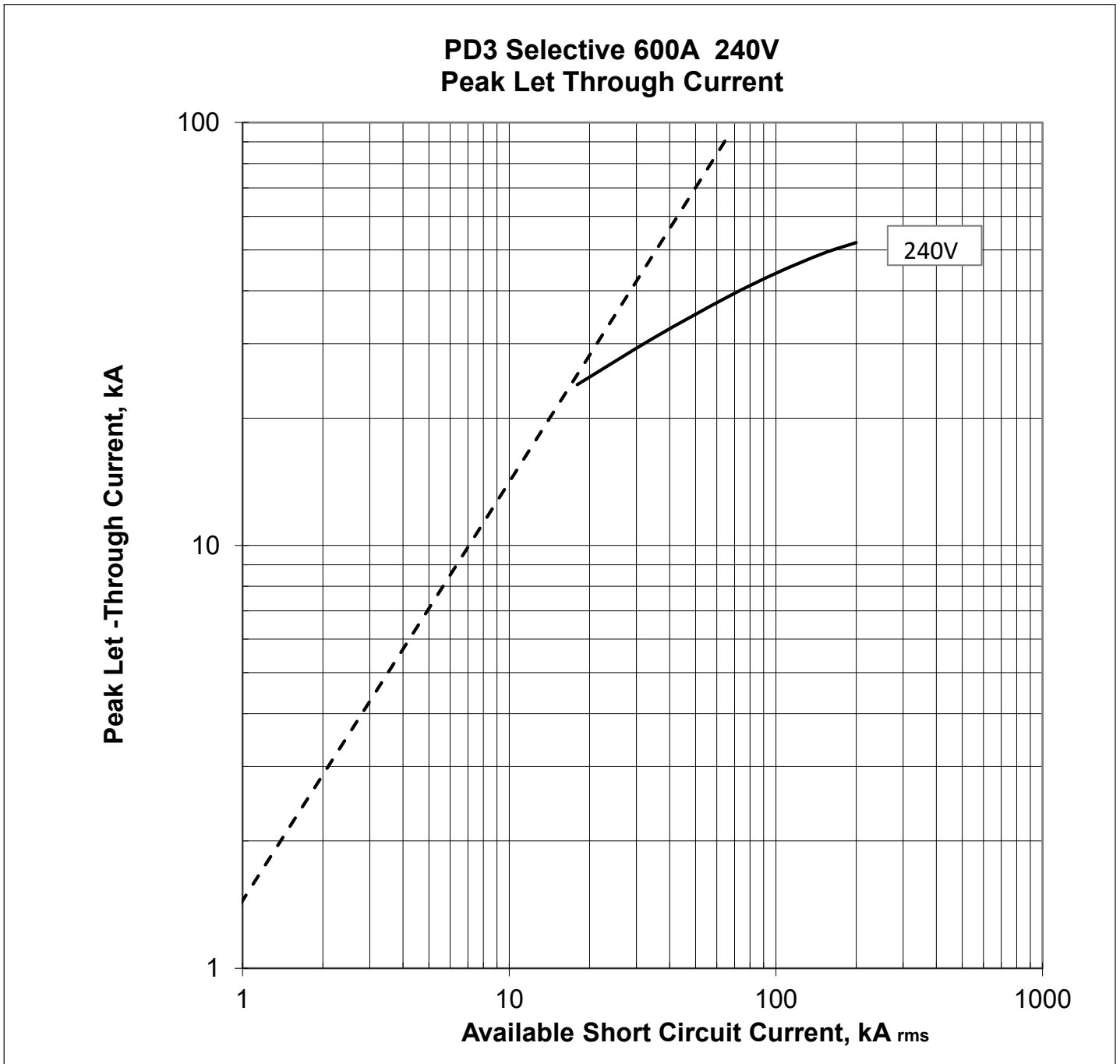

Figure 59. Peak let through current selective frames 600A @ 240V.

November 2019

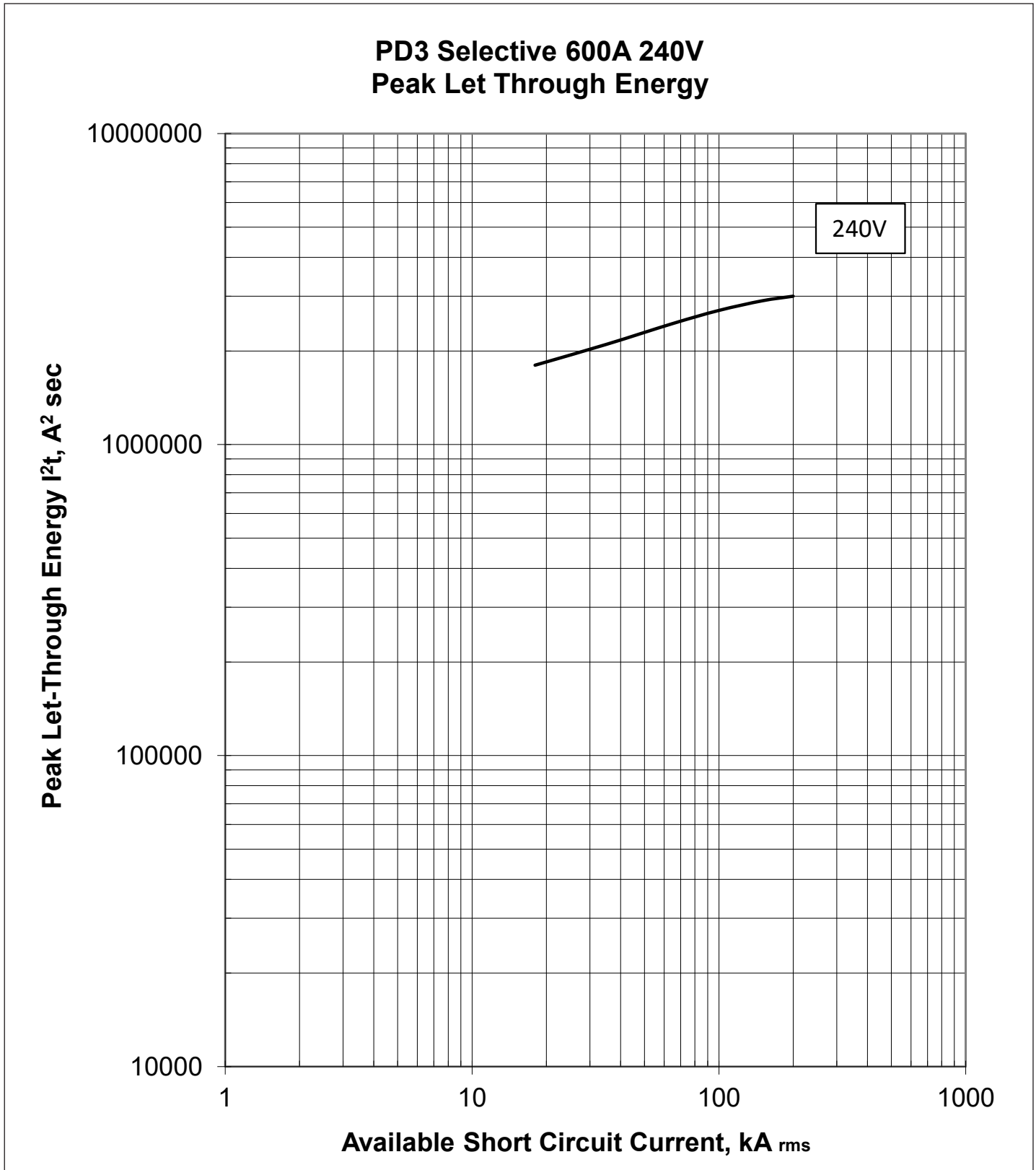

Figure 60. Peak let through energy selective frames 600A @ 240V.

November 2019

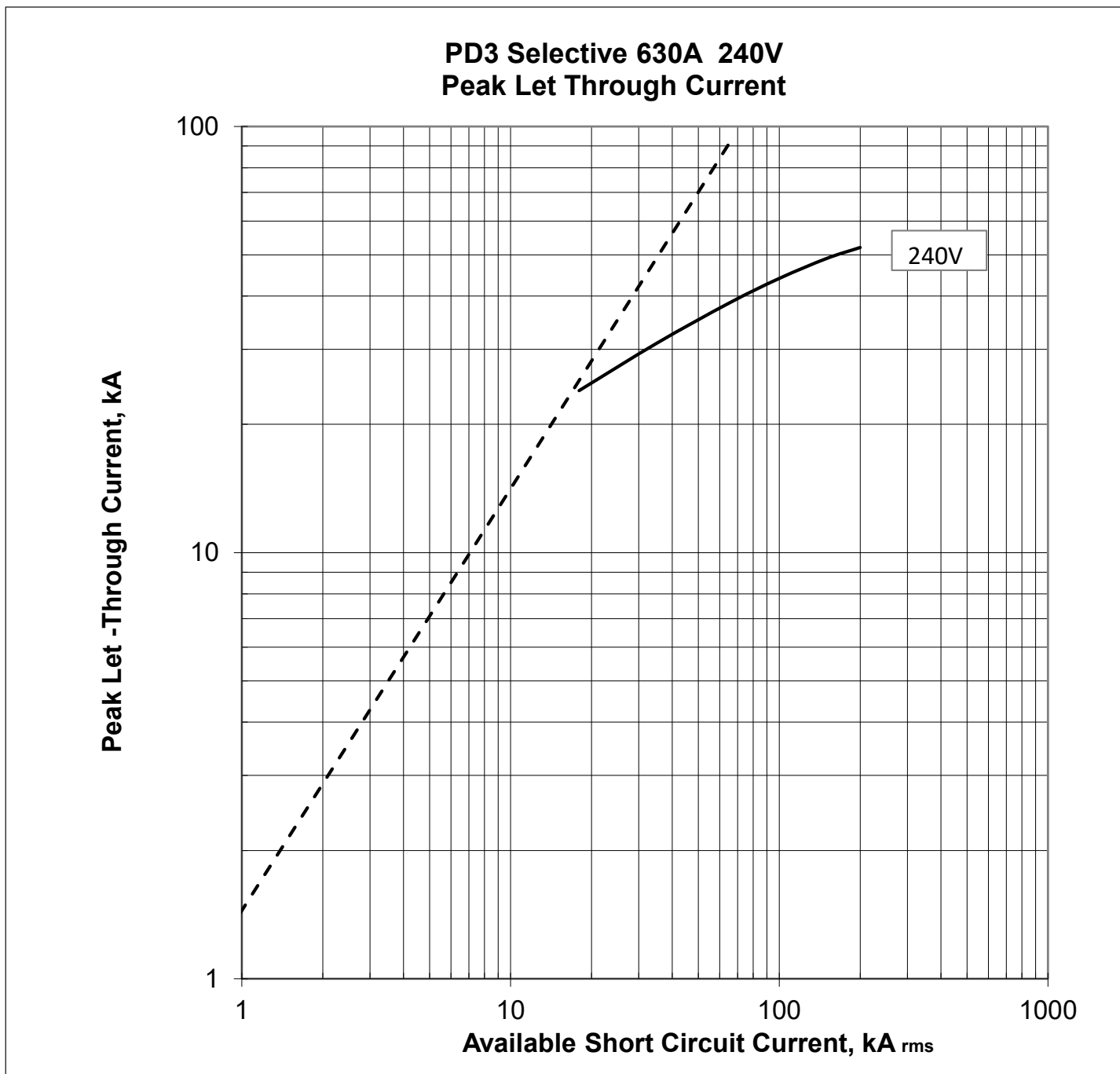

Figure 61. Peak let through current selective frames 630A @ 240V.

November 2019

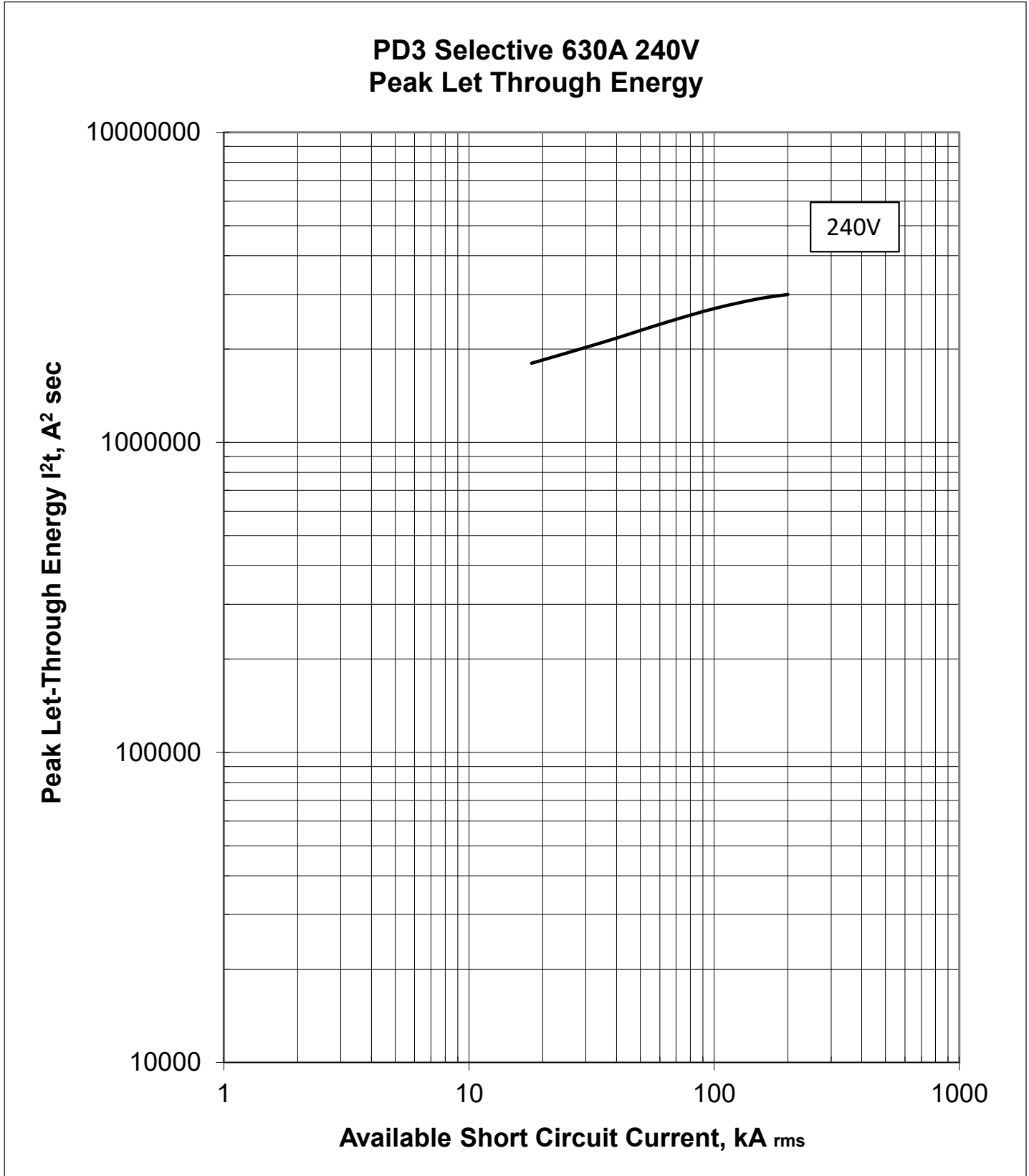

Figure 62. Peak let through energy selective frames 630A @ 240V.

November 2019.

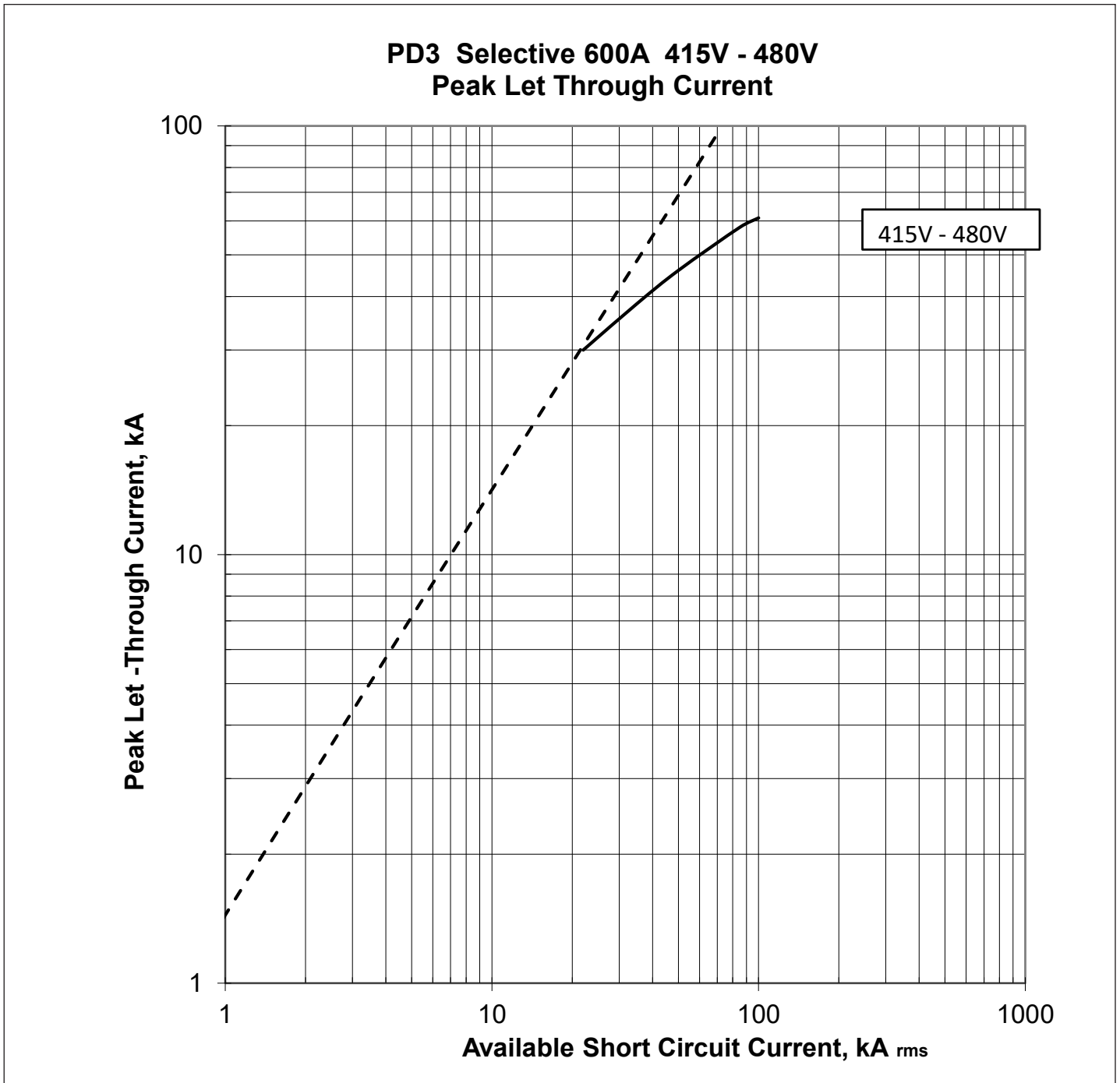

Figure 63. Peak let through current selective 600A @ 415V-480V.

November 2019

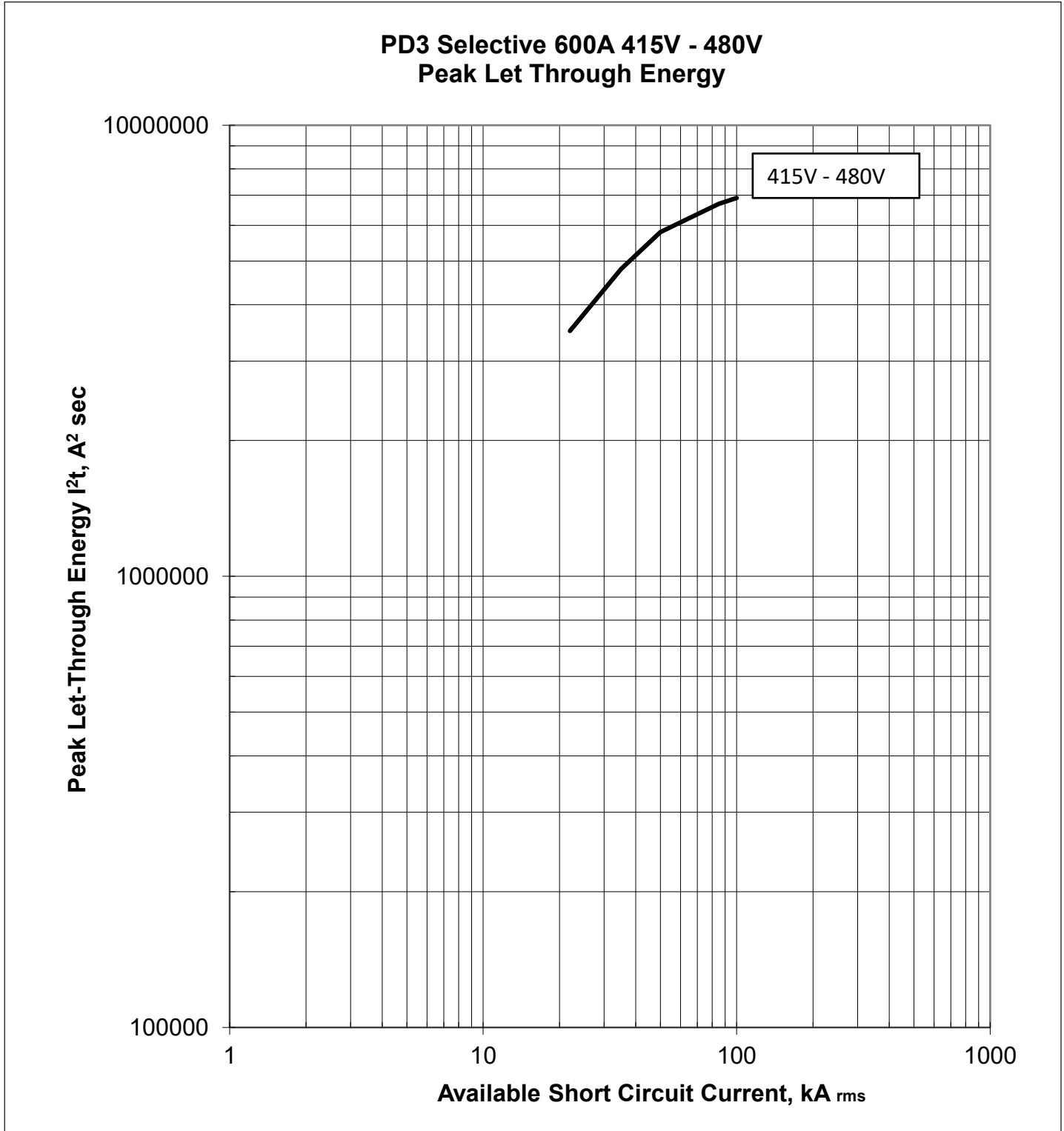

Figure 64. Peak let through energy selective 600A @ 415V-480V.

November 2019

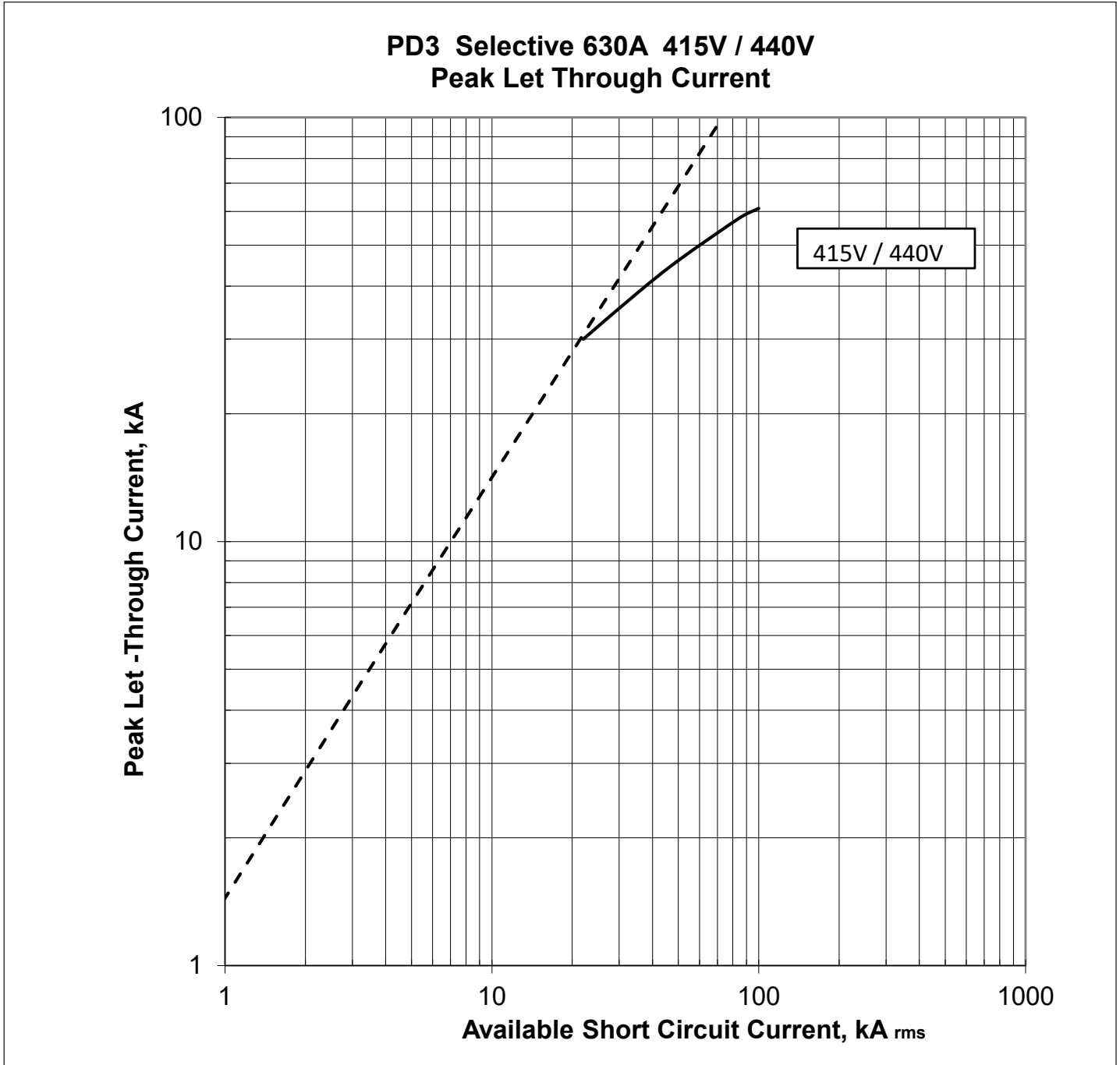

Figure 65. Peak let through current selective 630A @ 415V-440V.

November 2019

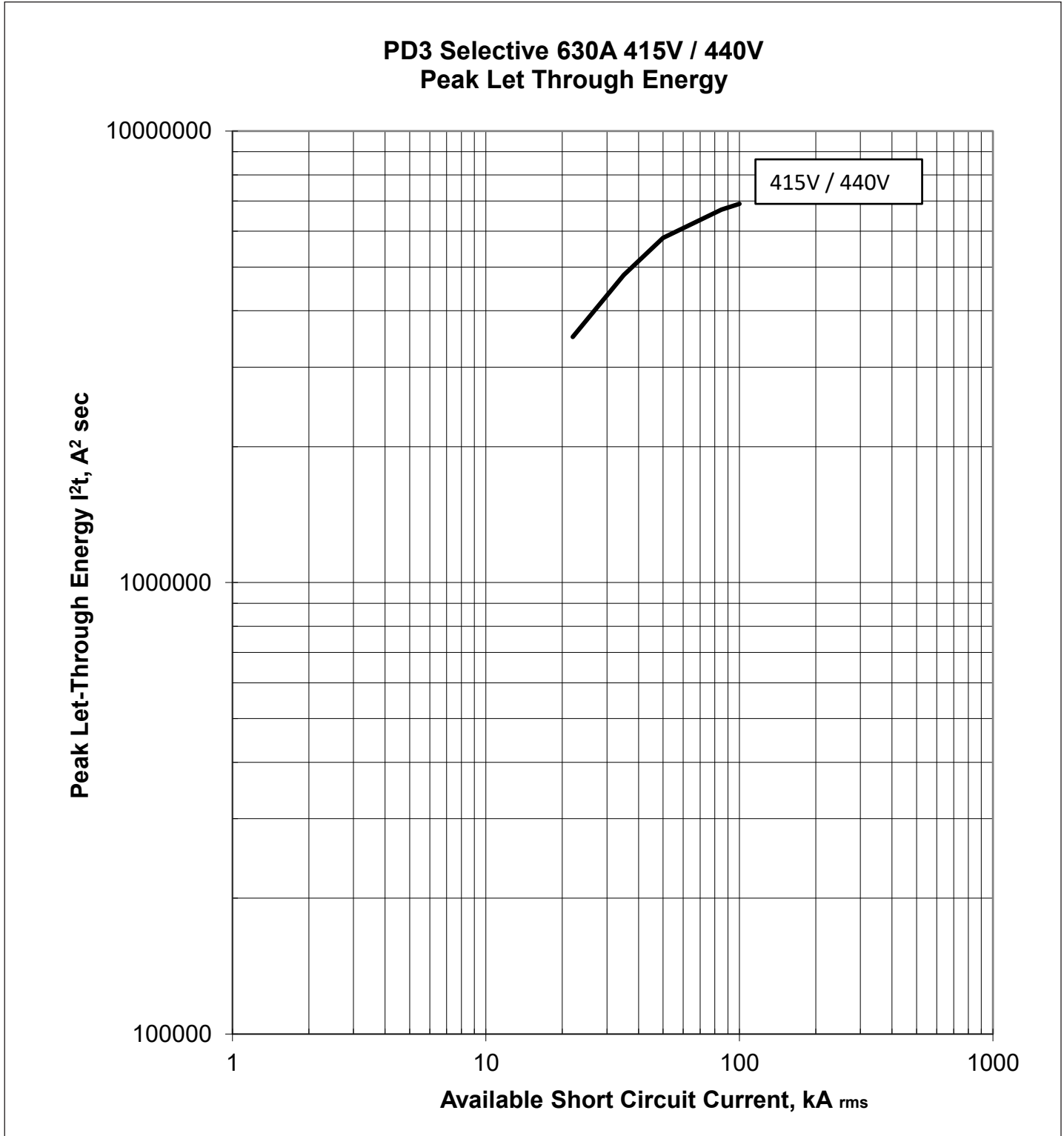

Figure 66. Peak let through energy selective 630A @ 415V-440V.

November 2019

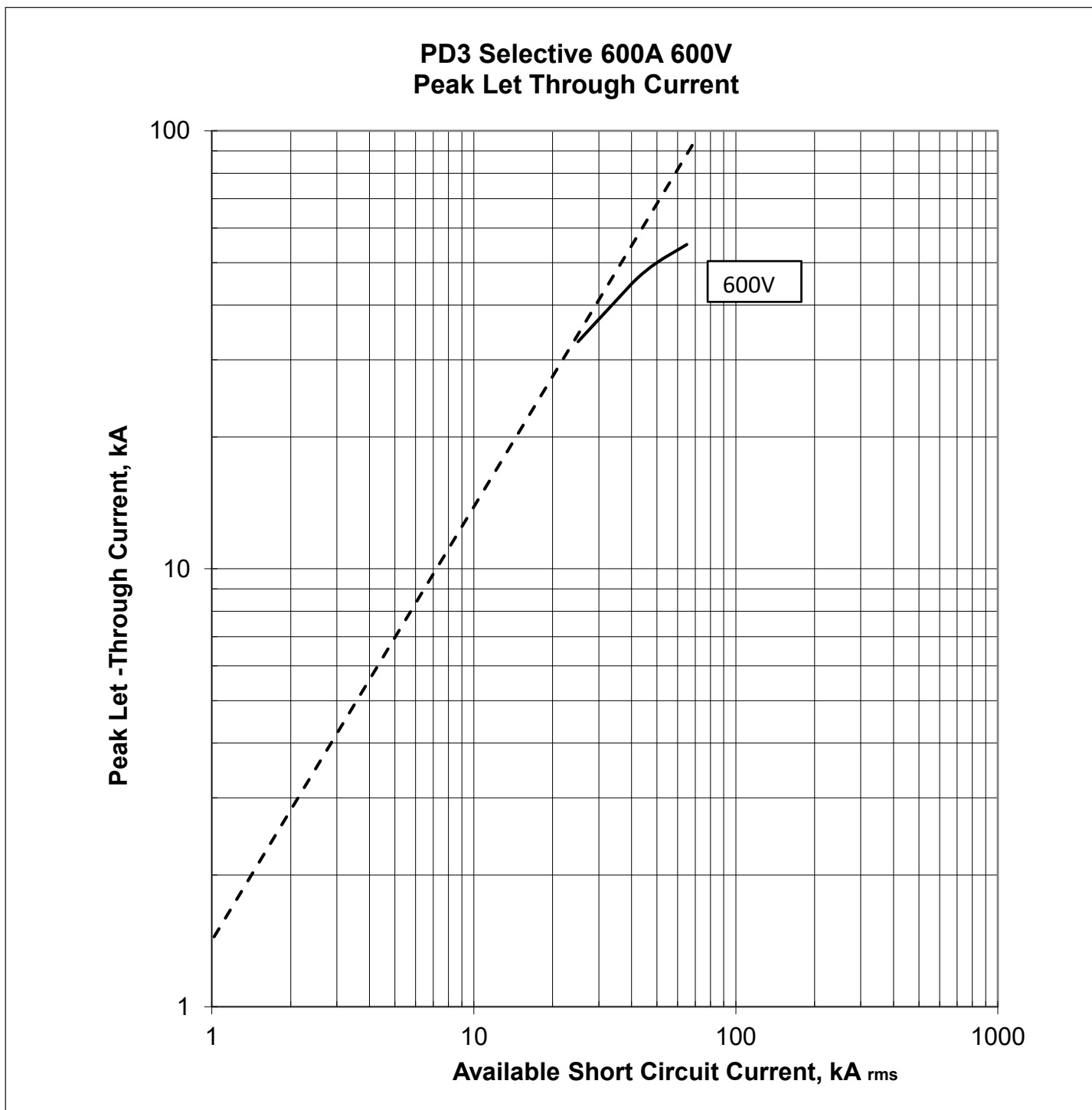

Figure 67. Peak let through current selective 600A @ 600V.

November 2019

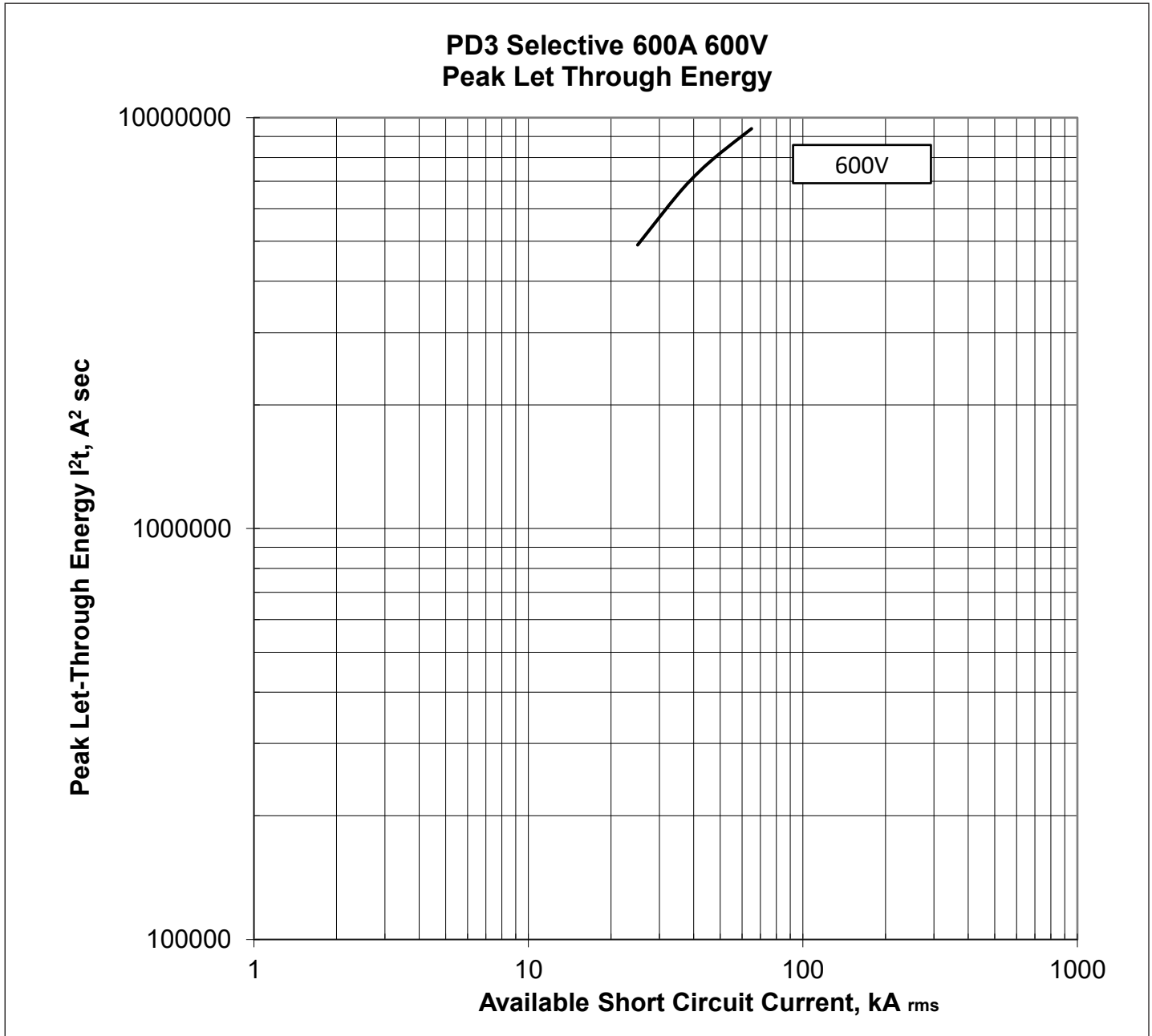

Figure 68. Peak let through energy selective 600A @ 600V.

November 2019

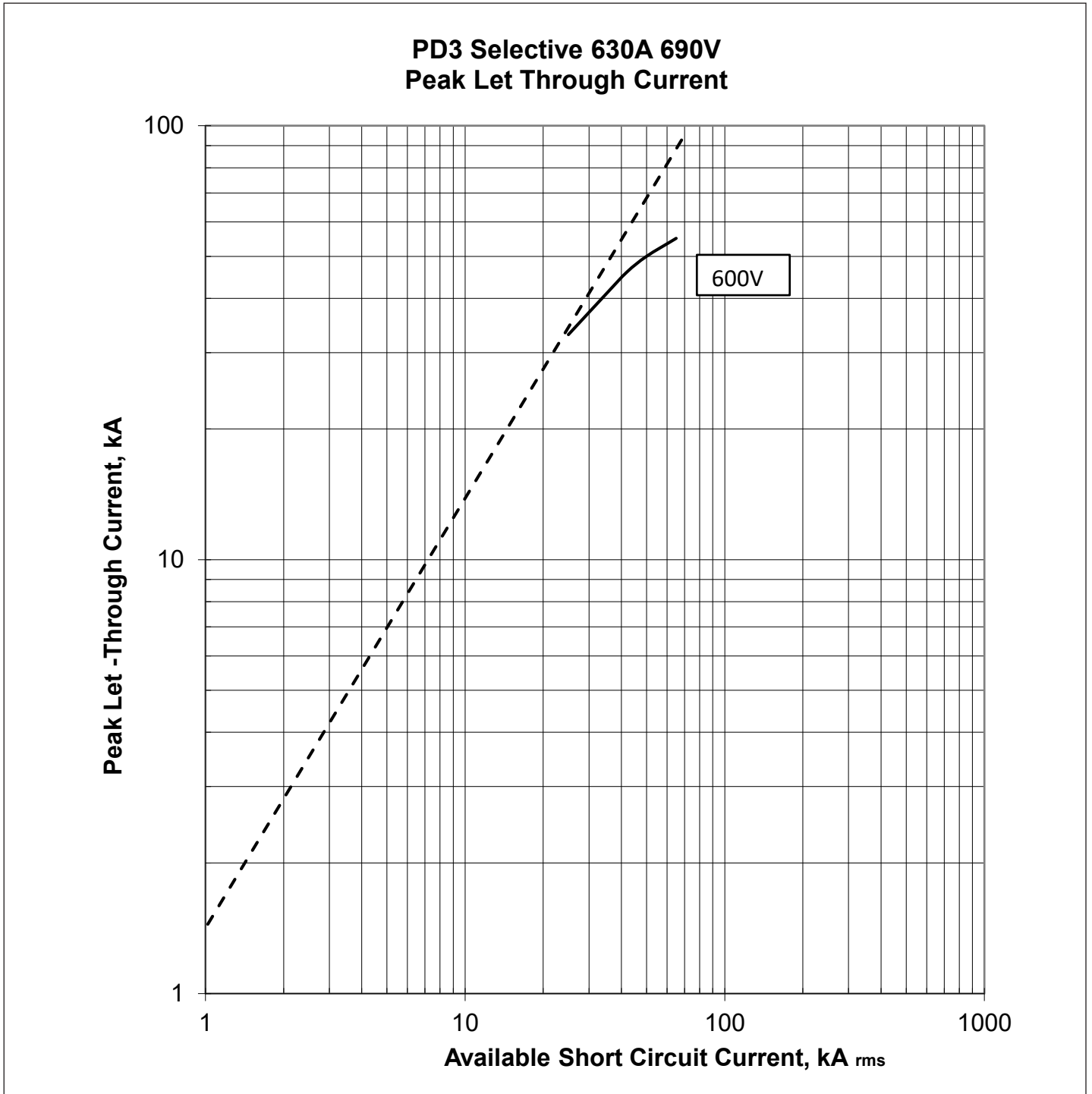

Figure 69. Peak let through current selective 630A @ 690V.

November 2019

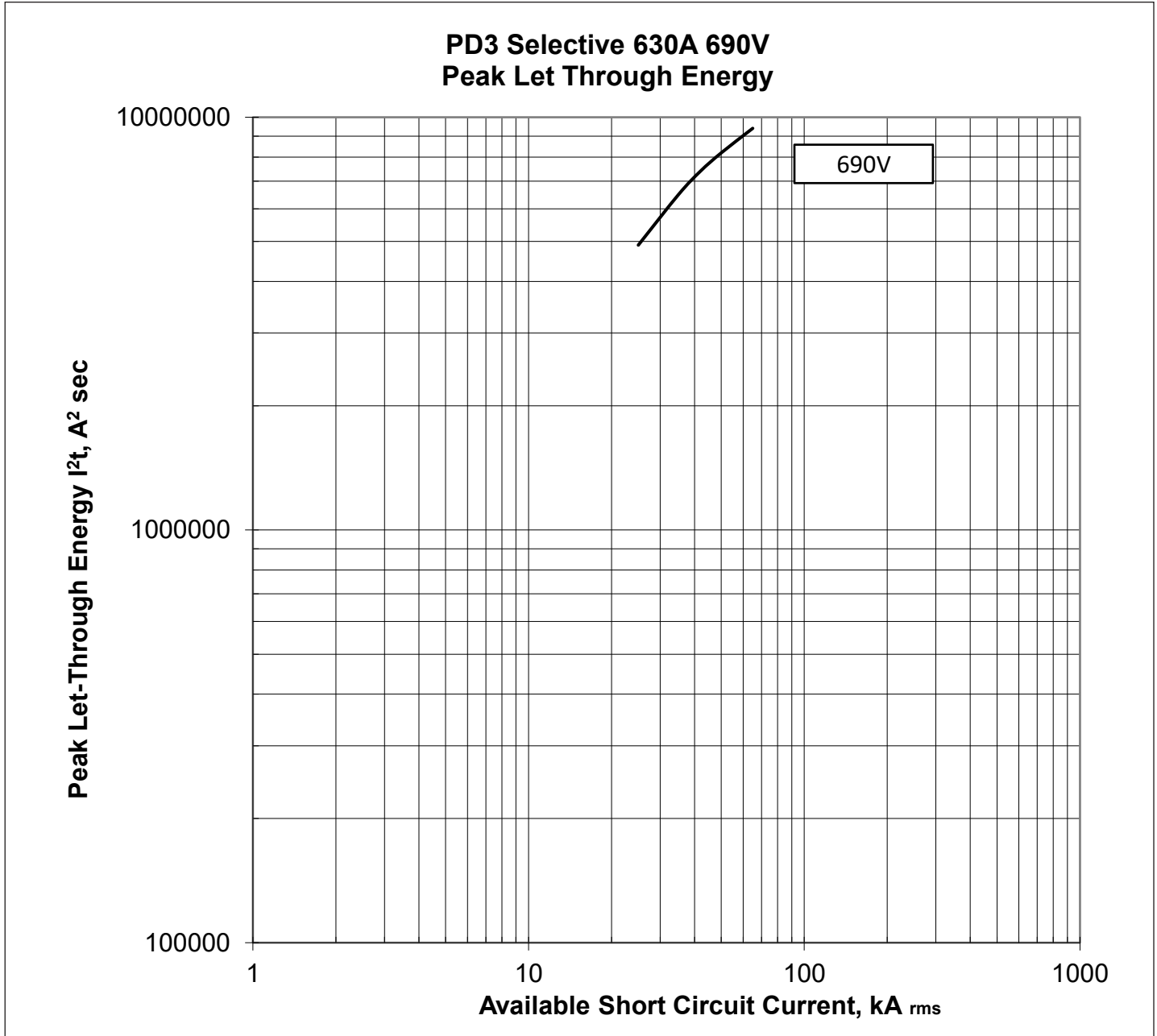

Figure 70. Peak let through energy selective 630A @ 690V

November 2019.

Eaton
1000 Eaton Boulevard
Cleveland, OH 44122
United States
877-ETN-CARE (877-386-2273)
Eaton.com

© 2019 Eaton
All Rights Reserved
Printed in USA
Publication No. TD012065EN / TBG001436
November 2019

Eaton is a registered trademark.

All other trademarks are property of their respective owners.