



Power Defense™

For PDG1 Frame

IL012175EN H01

PDG1 TERMINAL SHIELD/COVER IP30, 4P
Cat. No - PDG1XTC4P
Style No - 66A1590G31
Quantity - 1

Package Content:

- 1 Warning label
- (A) 1 Terminal shield (Load / Line)
- (B) 1 Terminal shield cover
- (C) 3 Barriers (optional)
- (D) Wire Seal (not included)

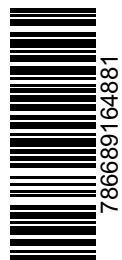
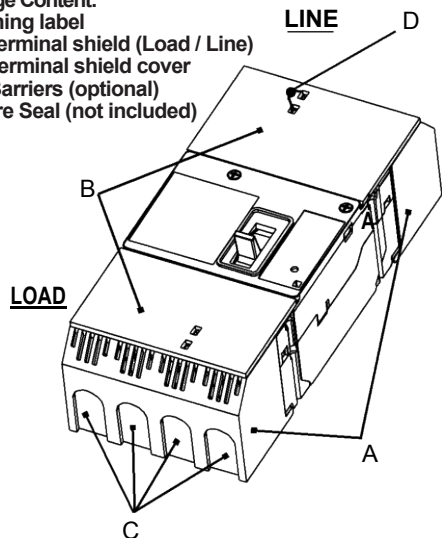

Power Defense™

For PDG1 Frame

IL012175EN H01

PDG1 TERMINAL SHIELD/COVER IP30, 4P
Cat. No - PDG1XTC4P
Style No - 66A1590G31
Quantity - 1

Package Content:

- 1 Warning label
- (A) 1 Terminal shield (Load / Line)
- (B) 1 Terminal shield cover
- (C) 3 Barriers (optional)
- (D) Wire Seal (not included)

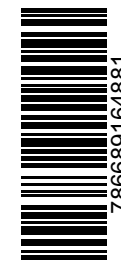
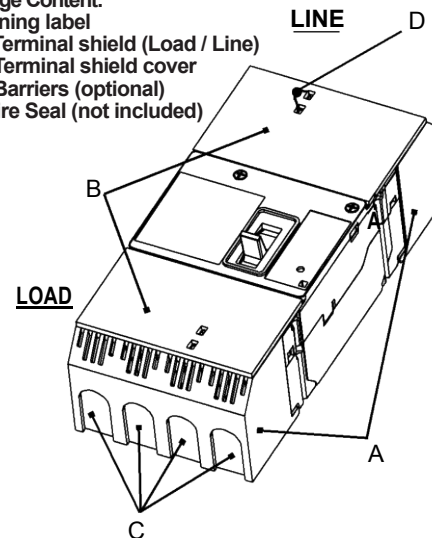

LINE / LOAD TERMINAL SHIELD KIT - 4 POLE (EXPLODED VIEW)

Read Warning label before proceeding

1. Remove Secondary Cover (6 screws).
2. Insert Barriers in slots (optional).
3. Slide the Terminal Shield down through the Breaker Slots while pulling bottom Shield Tabs outwards away from breaker.
4. Reinstall Secondary Cover (6 screws) 2,3 Tighten to 6—8 Lb-In.
5. **LOAD END ONLY** use pliers to break off Cover Extension. Press Terminal Shield Cover into the Secondary Cover. Secure cover with Wire Seal (not included).

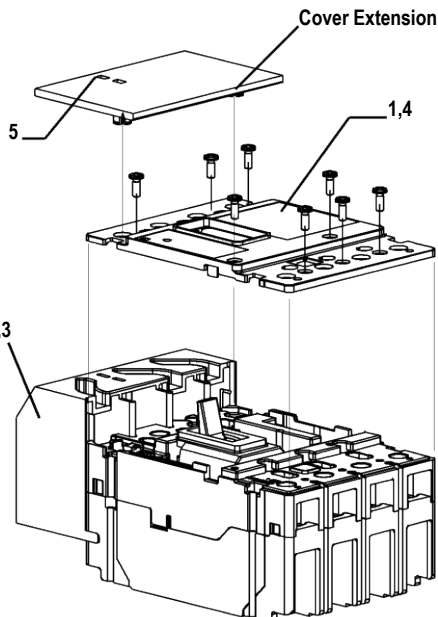

LINE / LOAD TERMINAL SHIELD KIT - 4 POLE (EXPLODED VIEW)

Read Warning label before proceeding

1. Remove Secondary Cover (6 screws).
2. Insert Barriers in slots (optional).
3. Slide the Terminal Shield down through the Breaker Slots while pulling bottom Shield Tabs outwards away from breaker.
4. Reinstall Secondary Cover (6 screws) 2,3 Tighten to 6—8 Lb-In.
5. **LOAD END ONLY** use pliers to break off Cover Extension. Press Terminal Shield Cover into the Secondary Cover. Secure cover with Wire Seal (not included).

