

Instructions for Padlockable Handle Lock Hasp Installed on Eaton PD6 Circuit Breakers and Molded Case Switches

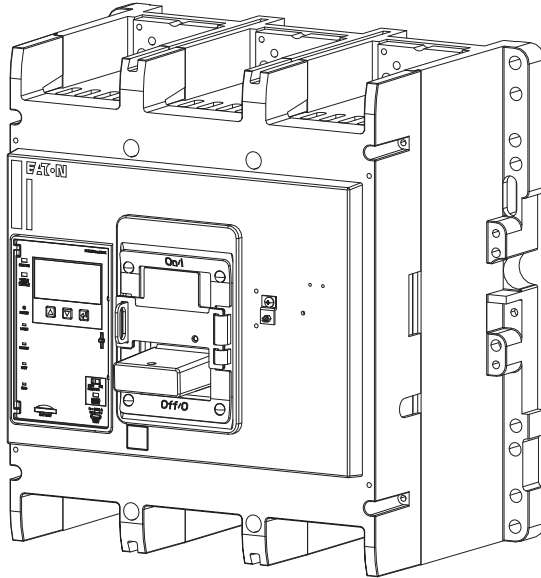

Contents

| Description | Page |
|-----------------------------|------|
| 1. General Information..... | 2 |
| 2. Installation..... | 3 |

Cat # PDG6XPLKR
PDG6XPLKROFF



WARNING

DO NOT ATTEMPT TO INSTALL OR PERFORM MAINTENANCE ON EQUIPMENT WHILE IT IS ENERGIZED. DEATH, SEVERE PERSONAL INJURY, OR SUBSTANTIAL PROPERTY DAMAGE CAN RESULT FROM CONTACT WITH ENERGIZED EQUIPMENT. ALWAYS VERIFY THAT NO VOLTAGE IS PRESENT BEFORE PROCEEDING WITH THE TASK, AND ALWAYS FOLLOW GENERALLY ACCEPTED SAFETY PROCEDURES.

EATON IS NOT LIABLE FOR THE MISAPPLICATION OR MISINSTALLATION OF ITS PRODUCTS.

The user is cautioned to observe all recommendations, warnings, and cautions relating to the safety of personnel and equipment as well as all general and local health and safety laws, codes, and procedures.

The recommendations and information contained herein are based on Eaton experience and judgement, but should not be considered to be all-inclusive or covering every application or circumstance which may arise. If any questions arise, contact Eaton for further information or instructions.

GENERAL INFORMATION

The padlockable handle lock hasp (Figs. 1-1 and 1-2) is used to externally lock the circuit breaker handle. Safety is ensured since the trip-free circuit breaker mechanism is capable of tripping when the handle is locked in the on position. The hasp lock has been evaluated by Underwriters Laboratories as an Unlisted Component for use with R-Frame breakers.

The lock hasp consists of a mounting plate, lockplate, retaining bracket and retaining pin. The retaining bracket and retaining pin assembly is used to secure the lock

plate to the cover while turning the breaker ON or OFF. When the lock plate is positioned to block the circuit breaker handle it may be secured by placing one or more padlock shackles through the hasp on the mounting plate. The lock hasp is designed to accept a maximum of three padlock shackles, each with a maximum diameter of 5/16 in. (7.94 mm).

Two versions of the lock hasp are available: One permits the circuit breaker handle to be locked in both the on and off positions. The second permits the circuit breaker handle to be locked in the off position only.

| Cat. No. | Function |
|--------------|-------------|
| PDG6XPLKR | Lock ON/OFF |
| PDG6XPLKROFF | Lock OFF |

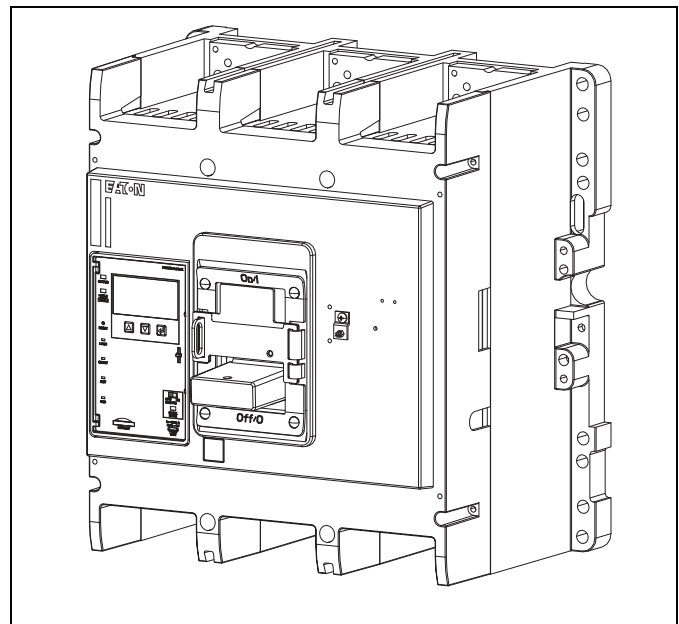
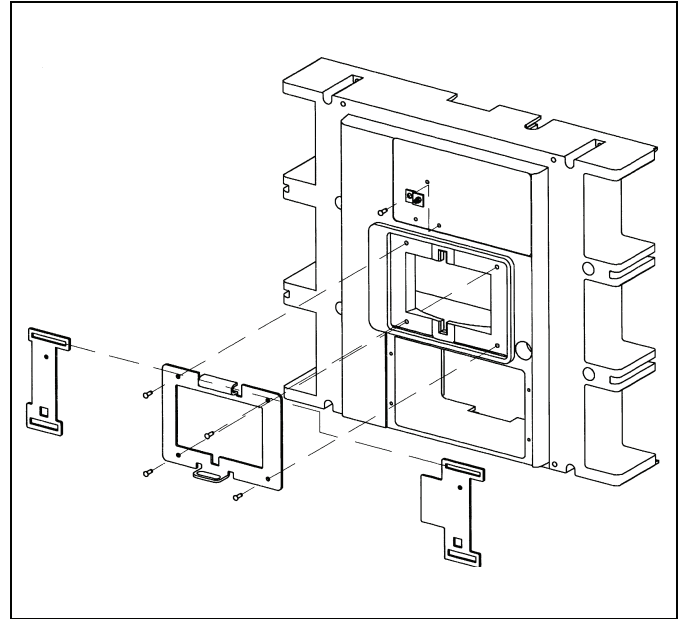

Fig. 1-1 Type HLK6 Padlockable Handle Lock Hasp Mounted on PD6 Circuit Breaker.

INSTALLATION

1. Screw the assembly on the cover with the hi-lo screw.
2. Hook the lock off (or on/off) plate onto the hasp mounting plate and check the orientation by closing the lock plate on the mounting plate.
3. Sit both pieces on the cover and align the holes. (The on and off stamped on the hasp mounting plate should match the on and off molded into the cover.)
4. Using a hammer and set punch, drive the four drive screws through the mounting plate and into the cover.
5. Check that the mounting plate is tight and the lock plate rotates freely and snaps onto the retainer.



*Fig. 1-2 Padlockable Handle Lock Hasp Mounting
Assembly on PD6 Circuit Breaker.*

The instructions for installation, testing, maintenance, or repair herein are provided for the use of the product in general commercial applications and may not be appropriate for use in nuclear applications. Additional instructions may be available upon specific request to replace, amend, or supplement these instructions to qualify them for use with the product in safety-related applications in a nuclear facility.

This Instruction Booklet is published solely for information purposes and should not be considered all-inclusive. If further information is required, you should consult an authorized Eaton sales representative.

The sale of the product shown in this literature is subject to the terms and conditions outlined in appropriate Eaton selling policies or other contractual agreement between the parties. This literature is not intended to and does not enlarge or add to any such contract. The sole source governing the rights and remedies of any purchaser of this equipment is the contract between the purchaser and Eaton.

NO WARRANTIES, EXPRESSED OR IMPLIED, INCLUDING WARRANTIES OF FITNESS FOR A PARTICULAR PURPOSE OR MERCHANTABILITY, OR WARRANTIES ARISING FROM COURSE OF DEALING OR USAGE OF TRADE, ARE MADE REGARDING THE INFORMATION, RECOMMENDATIONS, AND DESCRIPTIONS CONTAINED HEREIN.

In no event will Eaton be responsible to the purchaser or user in contract, in tort (including negligence), strict liability or otherwise for any special, indirect, incidental or consequential damage or loss whatsoever, including but not limited to damage or loss of use of equipment, plant or power system, cost of capital, loss of power, additional expenses in the use of existing power facilities, or claims against the purchaser or user by its customers resulting from the use of the information, recommendations and description contained herein.

Eaton
1000 Eaton Boulevard
Cleveland, OH 44122
United States
Eaton.com

© 2019 Eaton
All Rights Reserved
Printed in USA
Publication No. IL012292EN
Part No. IL012292EN HO1