

Instructions for Drilling and Assembling AMT Flex Shaft™ Handle Mechanism for PD6 Circuit Breakers and Molded Case Switches

Contents

Description	Page
General Information.....	2
Installation.....	4
Adjustment Checklist.....	4

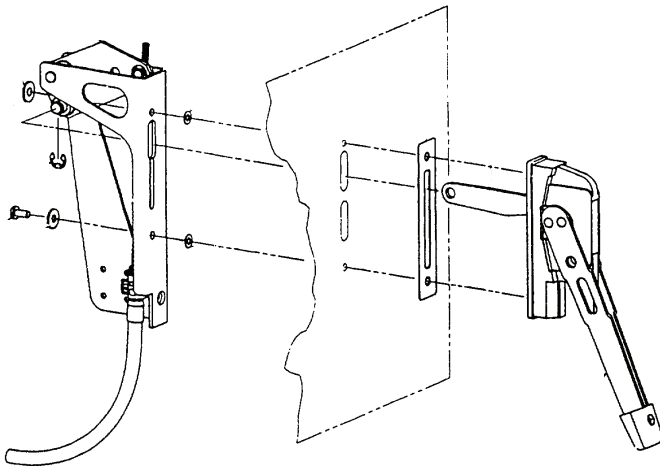



WARNING

DO NOT ATTEMPT TO INSTALL OR PERFORM MAINTENANCE ON EQUIPMENT WHILE IT IS ENERGIZED. SEVERE PERSONAL INJURY, DEATH, OR SUBSTANTIAL PROPERTY DAMAGE CAN RESULT FROM CONTACT WITH ENERGIZED EQUIPMENT. ALWAYS VERIFY THAT NO VOLTAGE IS PRESENT BEFORE PROCEEDING WITH THE TASK. AND ALWAYS FOLLOW GENERALLY ACCEPTED SAFETY PROCEDURES.

EATON IS NOT LIABLE FOR THE MISAPPLICATION OR MISINSTALLATION OF ITS PRODUCTS.

The user is cautioned to observe all recommendations, warnings, and cautions relating to the safety of personnel and equipment as well as all general and local health and safety laws, codes, and procedures.

The recommendations and information contained herein are based on Eaton experience and judgement, but should not be considered to be all-inclusive or covering every application or circumstance which may arise. If any questions arise, contact Eaton for further information or instructions.

GENERAL INFORMATION

The Shaft handle mechanism provides a means of externally operating the circuit breaker and can be applied to enclosures of varying heights and depths. The handle can be used with NEMA 1, 3R, and 12 enclosure applications, plus NEMA 4 and 4X applications, depending on the accessory components selected. An operating handle, flexible shaft, and mechanism are required for standard application. Three lengths of shafts are available for use with the range of depths of various enclosures (4, 5, and 6 ft [1.22, 1.52, and 1.83 m]). When selecting the length of the Flexible Shaft, ensure Minimum Bending Radius of 5 in. (127.00 mm) is maintained to operate properly. The flex shaft assembly is Underwriters Laboratories, Inc. listed under UL File E64983.



WARNING

WHEN INSTALLING A NEW HANDLE MECHANISM, OR A NEW CIRCUIT BREAKER AND HANDLE MECHANISM IN AN EXISTING ELECTRICAL SYSTEM, MAKE SURE THERE IS NO VOLTAGE PRESENT WHERE WORK IS TO BE PERFORMED. SPECIAL ATTENTION SHOULD BE PAID TO REVERSE FEED APPLICATIONS TO ENSURE NO VOLTAGE IS PRESENT. THE VOLTAGE IN ENERGIZED EQUIPMENT CAN CAUSE DEATH OR SEVERE PERSONAL INJURY.

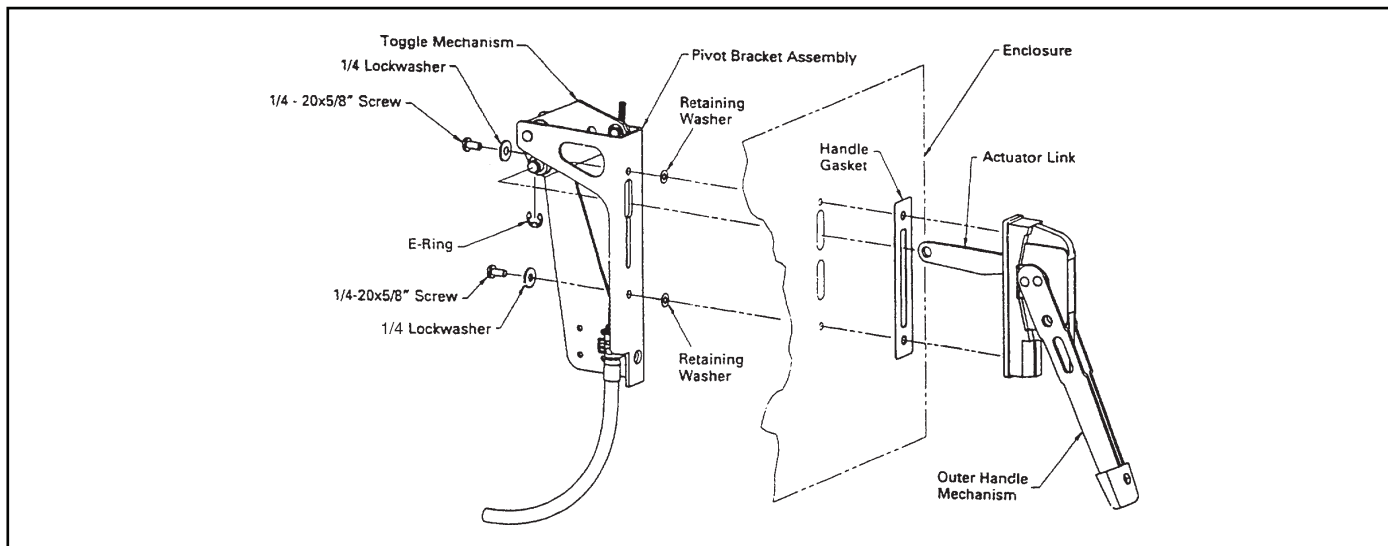

Fig. 1. Pivot Bracket and Outer Handle Mechanism Assembly.

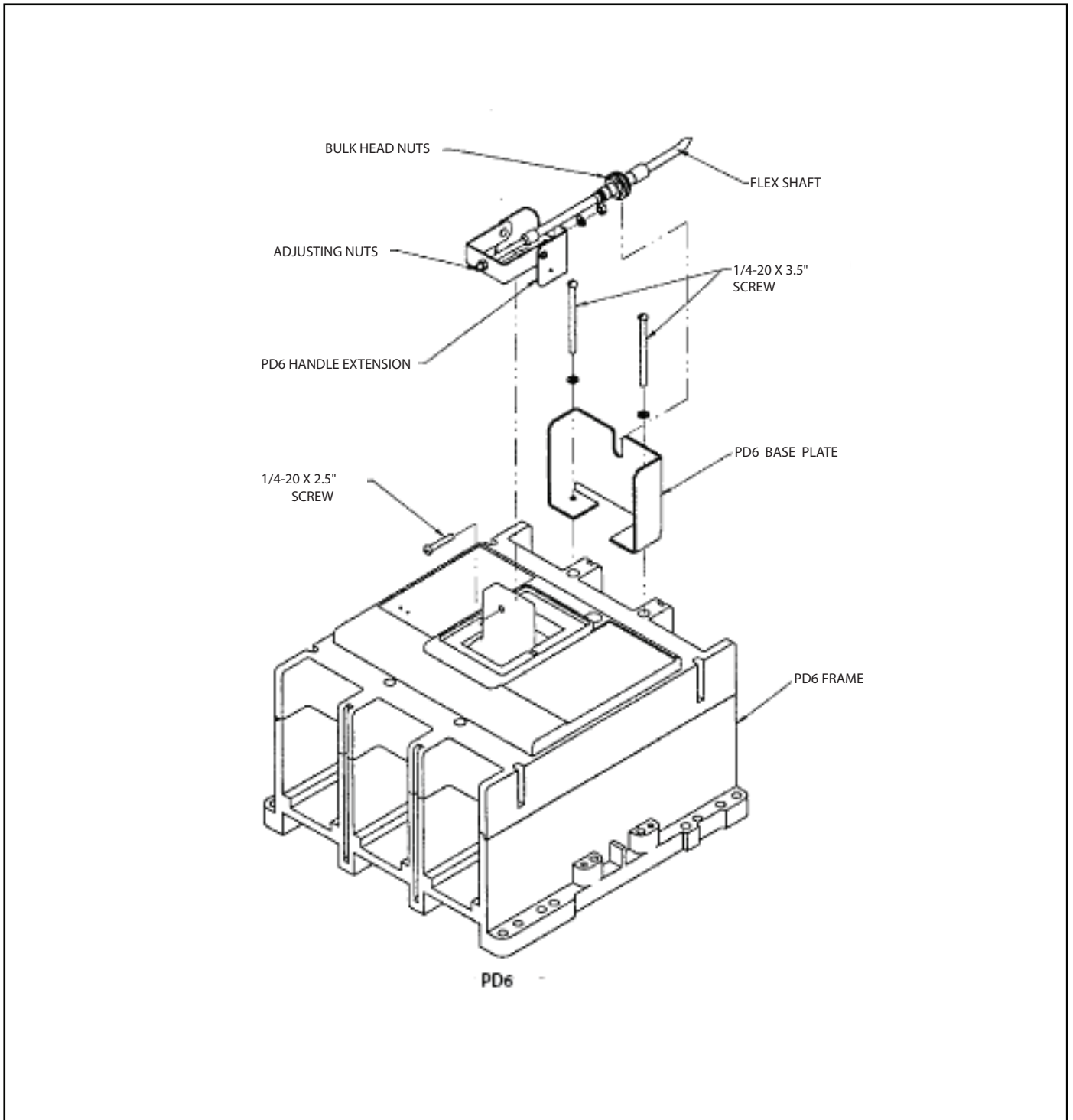

Fig. 2. PD6 Mechanism Assembly.

INSTALLATION

1. Remove the two 1/4-20 x 5/8" screws and lock-washers from the outer handle mechanism. Place each screw and lockwasher through the pivot bracket assembly. Thread the retaining washers enclosed in the parts kit onto the 1/4-20 x 5/8" screws. See Figure 1.
2. Connect the actuator link from the outer handle mechanism on the pivot bracket assembly. Mount the pivot bracket assembly to the enclosure and outer handle mechanism by securing the mounting hardware. Attach the E-Ring supplied in the parts kit to the actuator link. See Figure 1.
3. Drill and tap the mounting holes for the circuit breaker. See breaker frame instruction leaflet for the drilling pattern.

Note: Be certain that there is a 5 in. (127.00 mm) minimum clearance between the load end of the breaker and wall of the enclosure for the flex shaft.

4. Mount breaker's line end to enclosure using the mounting hardware supplied in the hardware kit.
5. Attach the base plate and mounting hardware to the load end of the circuit breaker per the following:

Attach the load end of the breaker to the enclosure using the hardware from the hardware kit. Attach the base plate to the circuit breaker using the 1/4- 20x3.75" screws and 1/4" lockwashers enclosed in the parts kit at the load end of the breaker. See Figure 2 for illustration.

6. Place the outer handle mechanism in the full **ON** position and the circuit breaker in the **ON** position. You must release cover interlock to move handle to **ON** position. Place the handle extension assembly onto the breaker handle and secure as shown on Figure 2.

PD6 uses a through bolt for handle attachment from the hardware kit.

7. Locate bulk head nuts of the flexible shaft over the groove of the base plate and tighten.
8. Actuate the outer handle positions (**ON, OFF, RESET**). If minor adjustments are necessary, refer to the following adjustment checklist and Figure 2.

Install appropriate door hardware (supplied); as referenced on Figure 3.

ADJUSTMENT CHECKLIST

Situation:

Breaker turns **ON** and **OFF**, but will not **RESET** when tripped.

Adjustment:

Loosen the 1/4-28 adjusting nut that is closest to the black cap and turn towards the cap about 1.5-2 turns. Re-tighten the adjusting nut that is on the end of the shaft to the handle extension and inner adjusting nut. Recheck for the **ON, OFF and RESET** position. If not successful, repeat procedure. If still not successful, and the adjusting nut is bottomed out onto the shaft, loosen the bulk head nuts, and shift the cable towards the load end of the breaker. Re-tighten the bulk head nuts. Recheck for the **ON, OFF and RESET** position. If not successful, repeat the beginning steps.

Situation:

Breaker resets after tripping, but does not turn **ON**.

Adjustment:

Loosen the 1/4-28 adjusting nut that is located on the end of the shaft and turn towards the end of the shaft about 1/5-2 turns. Re-tighten the adjusting nut that is closest to the black cap to the handle extension and the outing adjusting nut. Recheck for the **ON**, **OFF**, and **RESET** position. If not successful, and the adjusting nut on the end of the shaft is two threads from the end, loosen the bulk head nuts, and shift the cable towards the line end of the breaker. Re-tighten the bulk head nuts. Recheck for the **ON**, **OFF**, and **RESET** position. If not successful repeat the beginning steps.

If any other adjustment problems should arise, contact your local Eaton representative.

**AMT Flex Shaft Handle Mechanisms
Outline and Drilling Plans**

For Enclosure Door Interlock Assembly

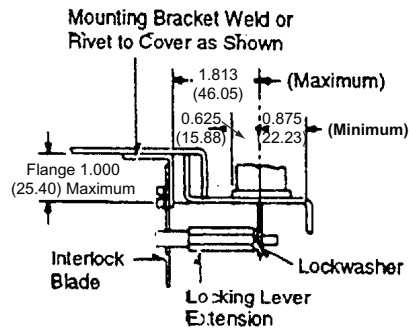
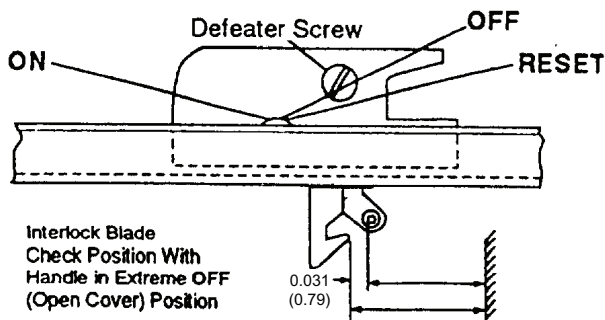
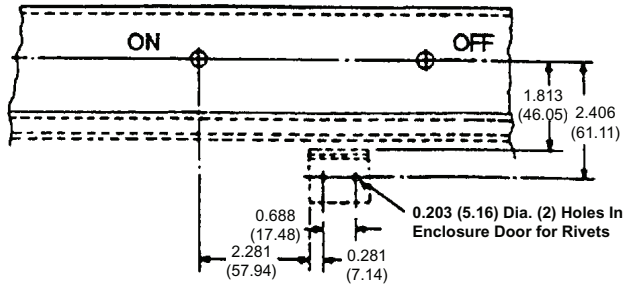

External Handle

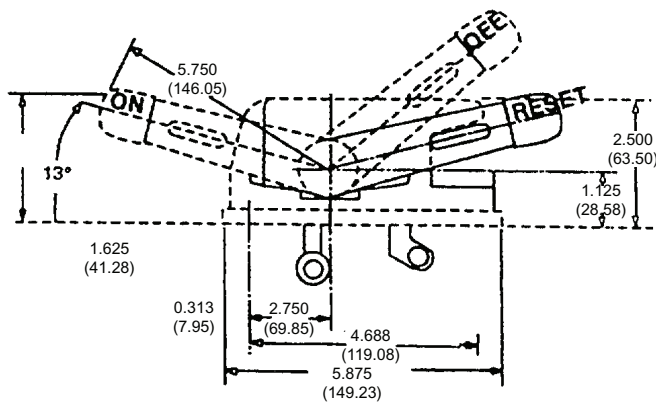

For Handle Flange

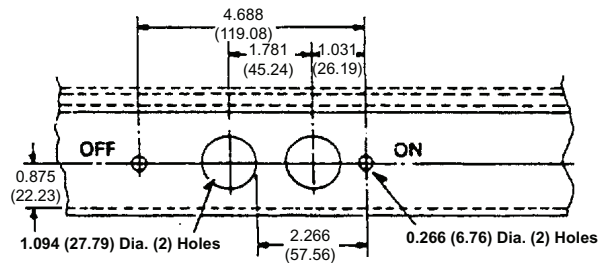

For Alternate Handle Flange

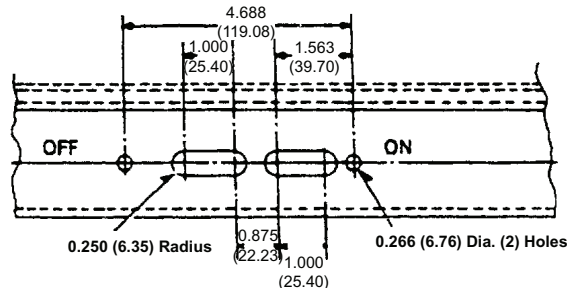

Fig. 3. Flange Drilling Plan for Handle and Interlock Blade Mounting Dimensions.

The instructions for installation, testing, maintenance, or repair herein are provided for the use of the product in general commercial applications and may not be appropriate for use in nuclear applications. Additional instructions may be available upon specific request to replace, amend, or supplement these instructions to qualify them for use with the product in safety-related applications in a nuclear facility.

This Instruction Booklet is published solely for information purposes and should not be considered all-inclusive. If further information is required, you should consult an authorized Eaton sales representative.

The sale of the product shown in this literature is subject to the terms and conditions outlined in appropriate Eaton selling policies or other contractual agreement between the parties. This literature is not intended to and does not enlarge or add to any such contract. The sole source governing the rights and remedies of any purchaser of this equipment is the contract between the purchaser and Eaton.

NO WARRANTIES, EXPRESSED OR IMPLIED, INCLUDING WARRANTIES OF FITNESS FOR A PARTICULAR PURPOSE OR MERCHANTABILITY, OR WARRANTIES ARISING FROM COURSE OF DEALING OR USAGE OF TRADE, ARE MADE REGARDING THE INFORMATION, RECOMMENDATIONS, AND DESCRIPTIONS CONTAINED HEREIN.

In no event will Eaton be responsible to the purchaser or user in contract, in tort (including negligence), strict liability or otherwise for any special, indirect, incidental or consequential damage or loss whatsoever, including but not limited to damage or loss of use of equipment, plant or power system, cost of capital, loss of power, additional expenses in the use of existing power facilities, or claims against the purchaser or user by its customers resulting from the use of the information, recommendations and description contained herein.

Eaton
1000 Eaton Boulevard
Cleveland, OH 44122
United States
Eaton.com

© 2019 Eaton
All Rights Reserved
Printed in USA
Publication No. IL012285EN
Part No. IL012285EN H01