

Instructions for Vertical Padlockable Handle Lock Hasp Installation on Eaton PD5 Circuit Breakers and Molded Case Switches

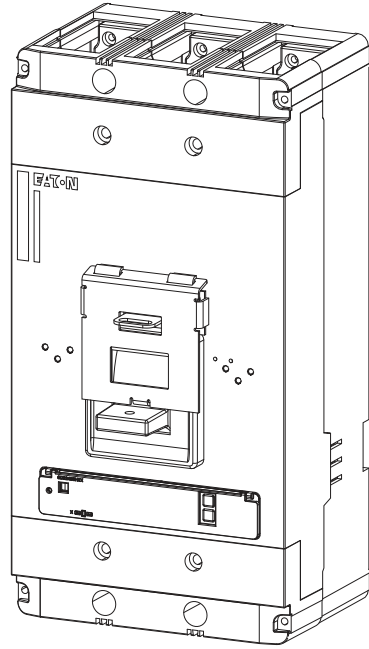

Contents

Description	Page
1. Introduction	2
2. Installation	2

Cat # PDG5XPLKT
PDG5XPLKTOFF



WARNING

DO NOT ATTEMPT TO INSTALL OR PERFORM MAINTENANCE ON EQUIPMENT WHILE IT IS ENERGIZED. DEATH, SEVERE PERSONAL INJURY, OR SUBSTANTIAL PROPERTY DAMAGE CAN RESULT FROM CONTACT WITH ENERGIZED EQUIPMENT. ALWAYS VERIFY THAT NO VOLTAGE IS PRESENT BEFORE PROCEEDING WITH THE TASK, AND ALWAYS FOLLOW GENERALLY ACCEPTED SAFETY PROCEDURES.

EATON IS NOT LIABLE FOR THE MISAPPLICATION OR MISINSTALLATION OF ITS PRODUCTS,

The user is cautioned to observe all recommendations, warnings, and cautions relating to the safety of personnel and equipment as well as all general and local health and safety laws, codes, and procedures.

The recommendations and information contained herein are based on Eaton experience and judgment, but should not be considered to be all-inclusive or covering every application or circumstance which may arise. If any questions arise, contact Eaton for further information or instructions.

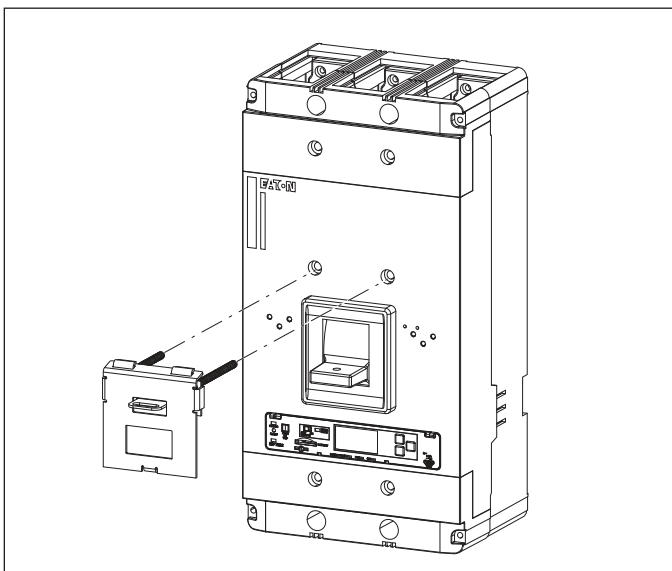

Figure 2 Padlockable Handle Lock Installation.

1. INTRODUCTION

General Information

The padlockable handle lock hasp (Fig. 2) is used to externally lock the circuit breaker handle in either the ON or OFF position or in the OFF only position depending upon the style being used. The on-off style hasp has a slot for the circuit breaker handle. Safety is ensured since trip-free operation lets the circuit breaker trip when the handle is locked in the ON position. The hasp is mounted on the circuit breaker cover above the handle. The hasp take up to three padlock shackles, each with a maximum diameter of 5/16 inch (7.94 mm).

The padlockable handle lock hasp has been evaluated by Underwriters Laboratories, Inc. as an unlisted component for use with these circuit breakers and molded case switches. It consists of a mounting plate connected by a hinge to a lockplate. The mounting plate includes the padlock staple. When the mounting plate is attached to the circuit breaker cover, the lockplate hinges over the mounting plate and staple. The lockplate prevents the circuit breaker handle from moving.

This instruction leaflet (IL) gives detailed procedures for installing the padlockable handle lock hasp.

2. INSTALLATION

The padlockable handle lock hasp is mounted above the handle of a 2-, 3-, and 4-pole circuit breaker. A padlockable handle lock hasp should normally be mounted on the circuit breaker cover before the circuit breaker is installed in an electrical system. To mount the padlockable handle lock hasp, perform the following steps.



WARNING

BEFORE MOUNTING THE PADLOCKABLE HANDLE LOCK HASP ON A CIRCUIT BREAKER INSTALLED IN AN ELECTRICAL SYSTEM, MAKE SURE THE CIRCUIT BREAKER IS SWITCHED TO THE OFF POSITION AND THAT THERE IS NO VOLTAGE PRESENT WHERE WORK IS TO BE PERFORMED.

SPECIAL ATTENTION SHOULD BE PAID TO REVERSE FEED APPLICATIONS TO ENSURE NO VOLTAGE IS PRESENT. THE VOLTAGES IN ENERGIZED EQUIPMENT CAN CAUSE DEATH OR SEVERE PERSONAL INJURY.

Note: When the padlockable handle lock hasp is mounted on the circuit breaker cover, a warning label is covered. A duplicate label is supplied with the mounting hardware. After the hasp lock has been mounted, the warning label must be placed on the breaker cover. (See Fig. 2).

The following steps describe how to mount the padlockable handle lock hasp to the circuit breaker.

Note: It is recommended that when installing the padlockable handle lock to the breaker the line and load end covers be in place. This will not permit the main cover from being removed during installation.

- 2-1. Remove and discard the two cover mounting screws above the handle. (See Fig. 2)
- 2-2. Position hasp base with hinges toward line end of breaker and align holes. (See Fig. 2)
- 2-3. Position long screws with flat washers and lock through hasp base and into cover mounting holes and start threads, but do not tighten. (See Fig. 2)

- 2-4. Position hasp latch to hasp base. Hasp plate hinge slots must be under base plate hinges (See Fig. 2)



CAUTION

FIRMLY TIGHTEN, BUT DO NOT OVERTIGHTEN, MOUNTING PLATE SCREWS. OVERTIGHTENING SCREWS CAN DAMAGE THE CIRCUIT BREAKER COVER. USE ONLY HARDWARE PROVIDED, DO NOT SUBSTITUTE.

- 2-6. Tighten mounting plate screws. Torque screws to 22 lb-in. (2.5 Nm.). Do not substitute hardware.

Note: Lockplate Retaining Feature - when the lockplate is hinged away from the mounting plate it can be retained in that position by sliding the lockplate to the right. (See Fig. 2)

- 2-7. Move circuit breaker handle to the OFF position. Hinge lockplate over staple. Check that padlock shackle fits through staple and that hasp latch blocks path of circuit breaker handle.
- 2-8. Remove padlock. Hinge lockplate away from circuit breaker handle. Move circuit breaker handle to the ON position. Hinge lockplate over staple and check that hasp latch blocks path of circuit breaker handle. Lock on-off only.

The instructions for installation, testing, maintenance, or repair herein are provided for the use of the product in general commercial applications and may not be appropriate for use in nuclear applications. Additional instructions may be available upon specific request to replace, amend, or supplement these instructions to qualify them for use with the product in safety-related applications in a nuclear facility.

This Instruction Booklet is published solely for information purposes and should not be considered all-inclusive. If further information is required, you should consult an authorized Eaton sales representative.

The sale of the product shown in this literature is subject to the terms and conditions outlined in appropriate Eaton selling policies or other contractual agreement between the parties. This literature is not intended to and does not enlarge or add to any such contract. The sole source governing the rights and remedies of any purchaser of this equipment is the contract between the purchaser and Eaton.

NO WARRANTIES, EXPRESSED OR IMPLIED, INCLUDING WARRANTIES OF FITNESS FOR A PARTICULAR PURPOSE OR MERCHANTABILITY, OR WARRANTIES ARISING FROM COURSE OF DEALING OR USAGE OF TRADE, ARE MADE REGARDING THE INFORMATION, RECOMMENDATIONS, AND DESCRIPTIONS CONTAINED HEREIN.

In no event will Eaton be responsible to the purchaser or user in contract, in tort (including negligence), strict liability or otherwise for any special, indirect, incidental or consequential damage or loss whatsoever, including but not limited to damage or loss of use of equipment, plant or power system, cost of capital, loss of power, additional expenses in the use of existing power facilities, or claims against the purchaser or user by its customers resulting from the use of the information, recommendations and description contained herein.

Eaton
1000 Eaton Boulevard
Cleveland, OH 44122
United States
Eaton.com

© 2019 Eaton
All Rights Reserved
Printed in USA
Publication No. IL012283EN
Part No. IL012283EN HO1