

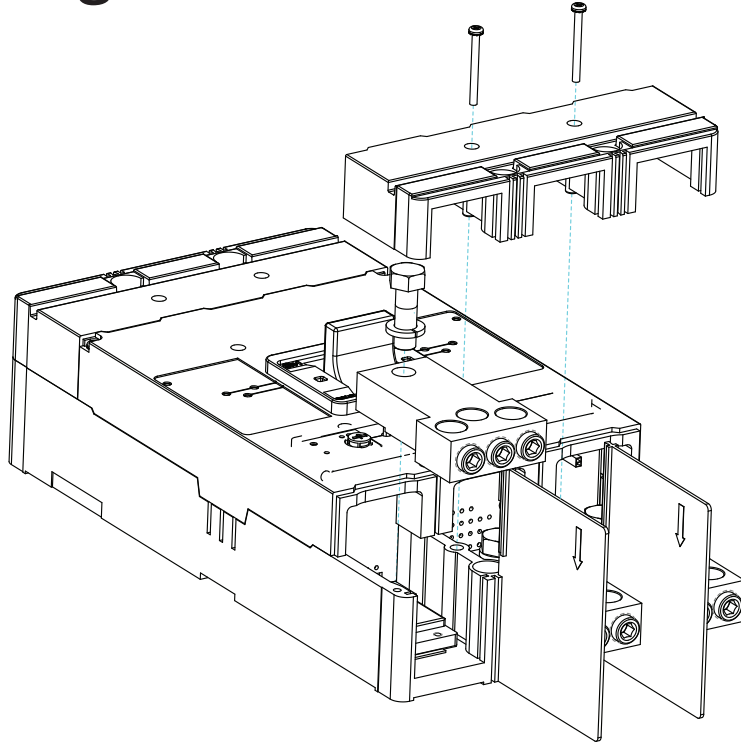

Eaton Circuit Breakers Reverse Feed Connector Kit Catalog No. PDG4X3(2)(4)TA800RF



Contents

| Description | Page |
|---------------------------------|------|
| Installation Instructions | 3 |

For use on Eaton PDG4 Frame Circuit Breakers,
Molded Case Switches, and Motor Circuit Protectors.

DANGER:  **DO NOT INSTALL OR PERFORM MAINTENANCE ON EQUIPMENT WHILE IT IS ENERGIZED. DEATH, SEVERE PERSONAL INJURY (INCLUDING BURN), OR SUBSTANTIAL PROPERTY DAMAGE CAN RESULT FROM CONTACT WITH ENERGIZED EQUIPMENT.**

ALWAYS VERIFY THAT NO VOLTAGE IS PRESENT BEFORE PROCEEDING WITH THE TASK.

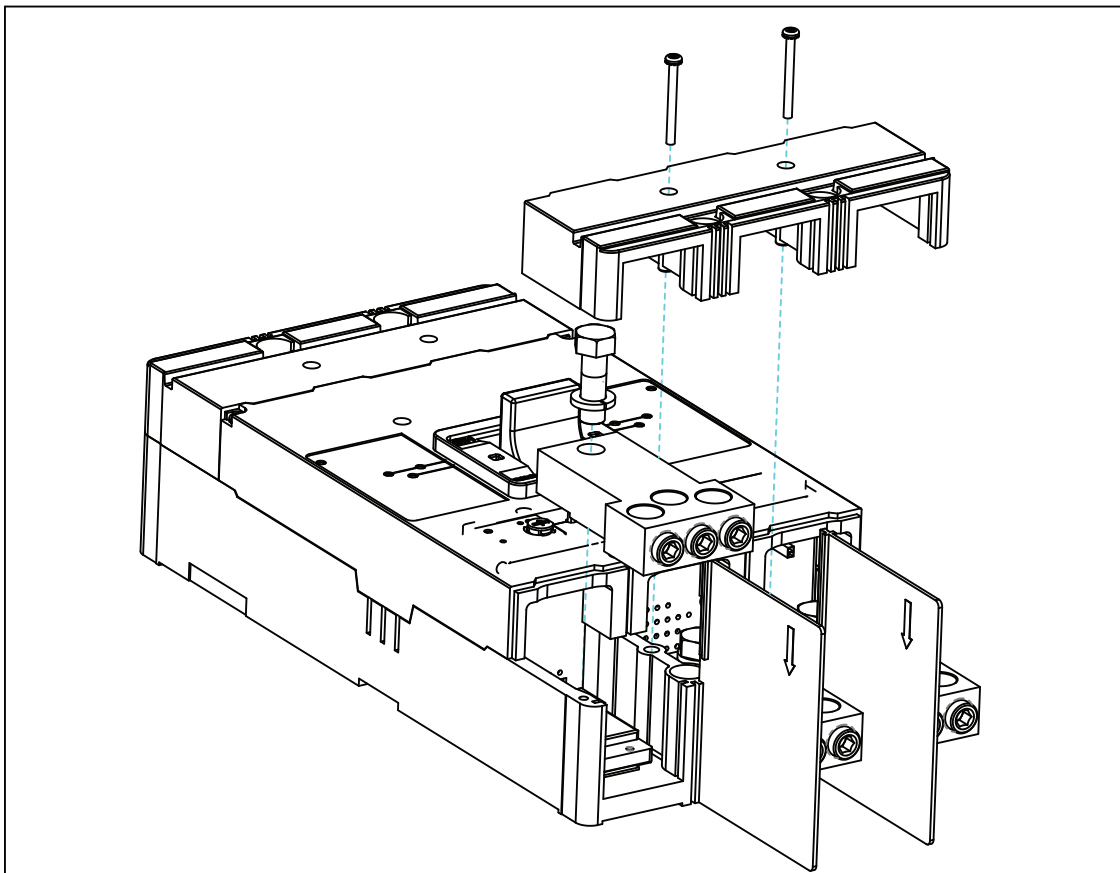

Fig. 1.

The installation and use of Eaton products should be in accordance with the provisions of the U.S. National Electrical Code and/or other government regulations, local codes, or industry standards that are pertinent to the particular end use installation or use not in accordance with these codes and standards could be hazardous to personnel and/or equipment.

Installation Instructions

To Install the Lugs:

1. Remove the two screws on the top and bottom of the MDL breaker's plastic terminal cover and remove the plastic cover from the breaker.
2. Align the lugs so the side with the step faces toward the breaker's terminal post. You will notice that the two steps go together. This is critical to provide additional protection in the case of a high fault.
3. Insert the large 1/2 - 1/3" hex head bolt through the lug and into the breaker's terminal post. Tighten to 30 - 35 ft-lbs (40.7 - 47.5 N·m).
4. Repeat steps 2 and 3 until all lugs are installed.
5. Re-install the terminal cover and tighten the terminal cover screws to 20 - 22 in-lbs (2.3-2.5 N·m).
6. Install the interphase barriers per the instructions printed on the bag. These can be trimmed down to reduce the height if desired, though care must be taken to ensure that the minimum creepage and clearance distances are maintained.

To Install Cable:

1. Choose the correct cable size for the application. Each lug can accommodate up to three cables from 2/0 - 400 kcmil.
2. Prepare Cable.
 - a. If using multi-stranded, flexible wire: We recommend the use of a ferrule on the end of the cable. This will ensure the strongest connection and reduce fatigue over time.
3. Insert the prepped cable(s) into the reverse lug.
4. Torque the terminal screw(s) to 275 in-lbs. (31.1 N·m)

The instructions for installation, testing, maintenance, or repair herein are provided for the use of the product in general commercial applications and may not be appropriate for use in nuclear applications. Additional instructions may be available upon specific request to replace, amend, or supplement these instructions to qualify them for use with the product in safety-related applications in a nuclear facility.

This Instruction Booklet is published solely for information purposes and should not be considered all-inclusive. If further information is required, you should consult an authorized Eaton sales representative.

The sale of the product shown in this literature is subject to the terms and conditions outlined in appropriate Eaton selling policies or other contractual agreement between the parties. This literature is not intended to and does not enlarge or add to any such contract. The sole source governing the rights and remedies of any purchaser of this equipment is the contract between the purchaser and Eaton.

NO WARRANTIES, EXPRESSED OR IMPLIED, INCLUDING WARRANTIES OF FITNESS FOR A PARTICULAR PURPOSE OR MERCHANTABILITY, OR WARRANTIES ARISING FROM COURSE OF DEALING OR USAGE OF TRADE, ARE MADE REGARDING THE INFORMATION, RECOMMENDATIONS, AND DESCRIPTIONS CONTAINED HEREIN.

In no event will Eaton be responsible to the purchaser or user in contract, in tort (including negligence), strict liability or otherwise for any special, indirect, incidental or consequential damage or loss whatsoever, including but not limited to damage or loss of use of equipment, plant or power system, cost of capital, loss of power, additional expenses in the use of existing power facilities, or claims against the purchaser or user by its customers resulting from the use of the information, recommendations and description contained herein.

Eaton Corporation
Electrical Sector
1111 Superior Ave.
Cleveland, OH 44114
United States
877-ETN-CARE (877-386-2273)
Eaton.com

© 2012 Eaton Corporation
All Rights Reserved
Printed in USA
Publication No. IL012254EN
Part No. IL012254EN H01