

Eaton Circuit Breakers Reverse Feed Connector Kit Catalog No. PDG3X3(2)(4)0TA400HRF

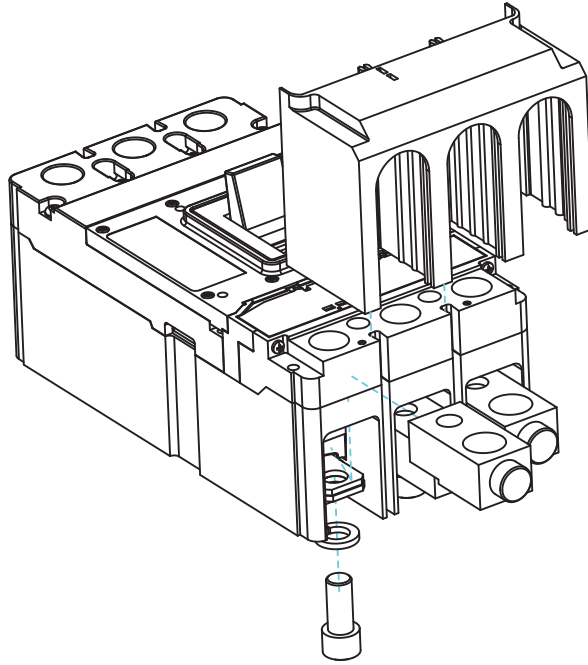

Contents

Description	Page
Installation Instructions	3

For use on Eaton PDG3 Frame Circuit Breakers,
Molded Case Switches, and Motor Circuit Protectors.

DANGER:



DO NOT INSTALL OR PERFORM MAINTENANCE ON EQUIPMENT WHILE IT IS ENERGIZED. DEATH, SEVERE PERSONAL INJURY (INCLUDING BURN), OR SUBSTANTIAL PROPERTY DAMAGE CAN RESULT FROM CONTACT WITH ENERGIZED EQUIPMENT.

ALWAYS VERIFY THAT NO VOLTAGE IS PRESENT BEFORE PROCEEDING WITH THE TASK.

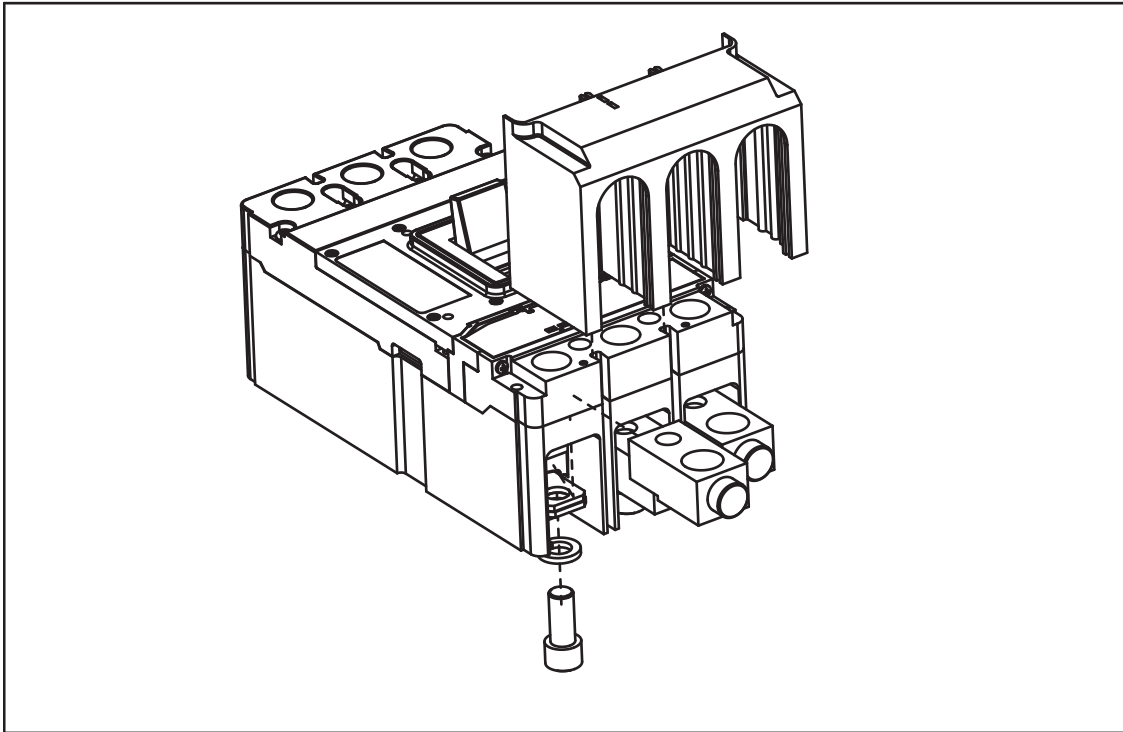

Fig. 1.

The installation and use of Eaton products should be in accordance with the provisions of the U.S. National Electrical Code and/or other government regulations, local codes, or industry standards that are pertinent to the particular end use installation or use not in accordance with these codes and standards could be hazardous to personnel and/or equipment.

Installation Instructions

To Install the Lugs:

1. Align the lugs so that the side with the step faces against the breaker's conductor. You will notice that the step locks to limit rotation. This is critical to provide additional protection in the case of a high fault.
2. Insert the 1/2" socket head cap screw and lock washer through the breaker conductor and into the terminal. Tighten to 200 lbs (22.6 N·m).
3. Repeat steps 1 and 2 until all lugs are installed.
4. Install the terminal cover and tighten the terminal cover screws to 6 - 8 in-lbs (0.7 - 0.9 N·m).

To Install Cable:

1. Choose the correct cable size for the application. Each lug can accommodate a cable from #3 - 500 mcm.
2. Prepare the cable.
 - a. If using multi-stranded, flexible wire, the use of a ferrule on the end of the cable is recommended to ensure the strongest connection and reduce fatigue over time.
3. Insert the prepared cable(s) into the reverse lug.
4. Torque the terminal screw(s) to 375 in-lbs (42.4 N·m).

The instructions for installation, testing, maintenance, or repair herein are provided for the use of the product in general commercial applications and may not be appropriate for use in nuclear applications. Additional instructions may be available upon specific request to replace, amend, or supplement these instructions to qualify them for use with the product in safety-related applications in a nuclear facility.

This Instruction Booklet is published solely for information purposes and should not be considered all-inclusive. If further information is required, you should consult an authorized Eaton sales representative.

The sale of the product shown in this literature is subject to the terms and conditions outlined in appropriate Eaton selling policies or other contractual agreement between the parties. This literature is not intended to and does not enlarge or add to any such contract. The sole source governing the rights and remedies of any purchaser of this equipment is the contract between the purchaser and Eaton.

NO WARRANTIES, EXPRESSED OR IMPLIED, INCLUDING WARRANTIES OF FITNESS FOR A PARTICULAR PURPOSE OR MERCHANTABILITY, OR WARRANTIES ARISING FROM COURSE OF DEALING OR USAGE OF TRADE, ARE MADE REGARDING THE INFORMATION, RECOMMENDATIONS, AND DESCRIPTIONS CONTAINED HEREIN.

In no event will Eaton be responsible to the purchaser or user in contract, in tort (including negligence), strict liability or otherwise for any special, indirect, incidental or consequential damage or loss whatsoever, including but not limited to damage or loss of use of equipment, plant or power system, cost of capital, loss of power, additional expenses in the use of existing power facilities, or claims against the purchaser or user by its customers resulting from the use of the information, recommendations and description contained herein.

Eaton Corporation
Electrical Sector
1111 Superior Ave.
Cleveland, OH 44114
United States
877-ETN-CARE (877-386-2273)
Eaton.com

© 2012 Eaton Corporation
All Rights Reserved
Printed in USA
Publication No. IL012252EN
Part No. IL012252EN H01