

Installation Instructions for PDG1 Multi-wire Terminal-Load Side (Aluminum) 125 amps, (3) AWG 14-6, 4 poles, Catalog No - PDG1X4TA1253W

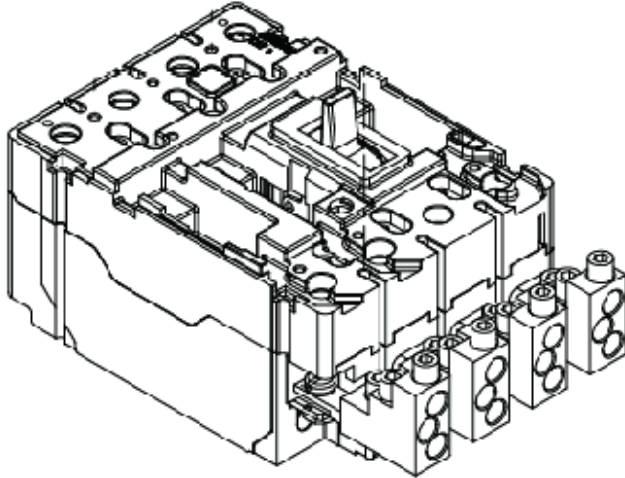

Contents

Description	Page
Multi-Wire Terminal Connector Kit Installation.....	2
Load Terminal Shield Kit Installation.....	3

! WARNING

DO NOT ATTEMPT TO INSTALL OR PERFORM MAINTENANCE ON EQUIPMENT WHILE IT IS ENERGIZED. SEVERE PERSONAL INJURY, DEATH, OR SUBSTANTIAL PROPERTY DAMAGE CAN RESULT FROM CONTACT WITH ENERGIZED EQUIPMENT. ALWAYS VERIFY THAT NO VOLTAGE IS PRESENT BEFORE PROCEEDING WITH THE TASK, AND ALWAYS FOLLOW GENERALLY ACCEPTED SAFETY PROCEDURES.

CUTLER-HAMMER IS NOT LIABLE FOR THE MISAPPLICATION OR MISINSTALLATION OF ITS PRODUCTS.

The user is cautioned to observe all recommendations, warnings, and cautions relating to the safety of personnel and equipment, as well as, all general and local health and safety laws, codes, and procedures.

The recommendations and information contained herein are based on Cutler-Hammer experience and judgement, but should not be considered to be inclusive or covering every application or circumstance which may arise. If any questions arise, contact Cutler-Hammer for further information or instructions.

1. INSTALLATION OF MULTI-WIRE TERMINAL CONNECTOR KIT (Fig. 1-1)

NOTE: For use on Cutler-Hammer EG Circuit Breakers, EG Moulded Case Switches, and HMCPE Motor Circuit Protectors on the LOAD END.

1. Remove secondary cover (8 screws).
2. Remove existing connector and discard.
3. Place Multi-Wire Connector on top of breaker terminal.
4. Install mounting screw, lock washer, washer and nut. Torque to 35 In-lbs.
5. Repeat steps 2-4 for remaining poles.
6. Apply torque label to side of breaker.

! CAUTION

THE PURPOSE OF THESE CONNECTORS IS TO DISTRIBUTE POWER TO MORE THAN ONE LOAD AND ARE TO BE INSTALLED ONLY ON THE "LOAD END" OF THE CIRCUIT BREAKER.

! WARNING

CONDUCTORS SIZED FOR LOAD CURRENTS LOWER THAN THE CIRCUIT BREAKER RATING WILL NOT BE PROTECTED BY THE CIRCUIT BREAKER. EACH LOAD CONDUCTOR MUST BE PROTECTED BY AN INDIVIDUAL OVERCURRENT DEVICE, AND MEET ANY ADDITIONAL REQUIREMENTS OF THE NATIONAL ELECTRIC CODE.

Table 1-1 Wire strip lengths for connector hole locations

HOLE POSITION	WIRE STRIP LENGTH
Upper	3/8 to 1/2 inch
Middle	3/4 to 7/8 inch
Lower	1 1/4 to 1 3/8 inch

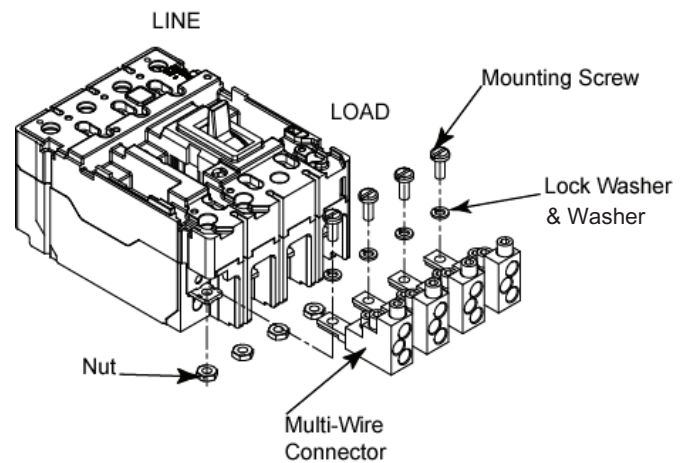

Fig. 1-1 Multi-Wire Connector Kit Installation Layout

INSTALLATION OF LOAD TERMINAL SHIELD KIT (Fig. 2-1)

- 1. Slide the Terminal Shield down through the breaker slots while pulling bottom shield tabs outwards away from breaker.
- 2. Reinstall secondary cover (8 screws). Tighten to 10-13 in-Lb.
- 3. Use pliers to break off cover extension. Press cover extension into the secondary cover.

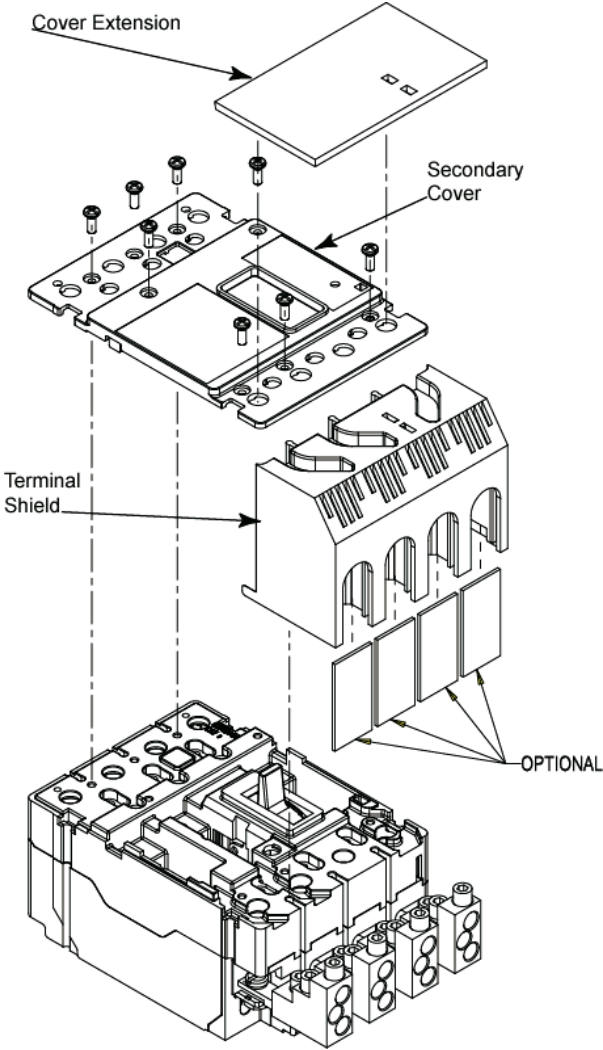

Fig. 2-1 Load Terminal Shield Kit Installation Layout.

Instruction Leaflet IL012199EN

Effective Sept 2018

The instructions for installation, testing, maintenance, or repair herein are provided for the use of the product in general commercial applications and may not be appropriate for use in nuclear applications. Additional instructions may be available upon specific request to replace, amend, or supplement these instructions to qualify them for use with the product in safety-related applications in a nuclear facility.

The information, recommendations, descriptions, and safety notations in this document are based on Eaton's experience and judgment with respect to Retrofitting of Power Breakers. This instructional literature is published solely for information purposes and should not be considered all-inclusive. If further information is required, you should consult an authorized Eaton sales representative.

The sale of the product shown in this literature is subject to the terms and conditions outlined in appropriate Eaton selling policies or other contractual agreement between the parties. This literature is not intended to and does not enlarge or add to any such contract. The sole source governing the rights and remedies of any purchaser of this equipment is the contract between the purchaser and Eaton.

NO WARRANTIES, EXPRESSED OR IMPLIED, INCLUDING WARRANTIES OF FITNESS FOR A PARTICULAR PURPOSE OR MERCHANTABILITY, OR WARRANTIES ARISING FROM COURSE OF DEALING OR USAGE OF TRADE, ARE MADE REGARDING THE INFORMATION, RECOMMENDATIONS, AND DESCRIPTIONS CONTAINED HEREIN. In no event will Eaton be responsible to the purchaser or user in contract, in tort (including negligence), strict liability or otherwise for any special, indirect, incidental or consequential damage or loss whatsoever, including but not limited to damage or loss of use of equipment, plant or power system, cost of capital, loss of power, additional expenses in the use of existing power facilities, or claims against the purchaser or user by its customers resulting from the use of the information, recommendations and description contained herein.

Eaton is a registered trademark of Eaton Corporation.

All other trademarks are property of their respective owners.

Eaton Corporation
Electrical Sector
1111 Superior Ave
Cleveland, OH 44114
United States
877-ETN-CARE (877-386-2273)
Eaton.com

© 2018 Eaton Corporation
All Rights Reserved
Printed in USA
Publication No. IL012199EN
Part No. IL012199EN H01
Sept 2018



EAT•N

Qty. 1 PDG1X4TA1253W
PDG1 Multi-wire Terminal-Load
Side (Aluminum) 125 amps, (3)
AWG 14-6, 4 poles



786689165017