

# Installation Instructions for Alarm (Signal)/Lockout Switch for R-Frame Series C Circuit Breakers and Molded Case Switches

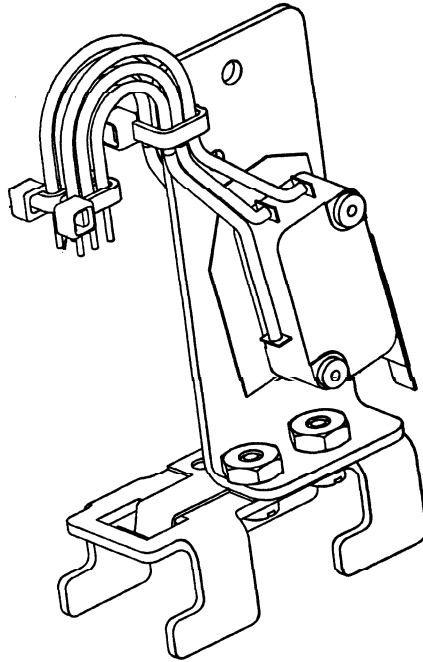

## Contents

Description	Page
1. Introduction .....	2
2. Installation .....	3



*Powering Business Worldwide*



## WARNING

**CONTACT WITH ENERGIZED EQUIPMENT CAN RESULT IN DEATH, SEVERE PERSONAL INJURY, OR SUBSTANTIAL PROPERTY DAMAGE. DO NOT ATTEMPT TO INSTALL OR PERFORM MAINTENANCE ON EQUIPMENT WHILE IT IS ENERGIZED. ALWAYS VERIFY THAT NO VOLTAGE IS PRESENT BEFORE PROCEEDING WITH THE TASK, AND ALWAYS FOLLOW GENERALLY ACCEPTED SAFETY PROCEDURES.**

**EATON IS NOT LIABLE FOR THE MISAPPLICATION OR MISINSTALLATION OF ITS PRODUCTS.**

The user is cautioned to observe all recommendations, warnings, and cautions relating to the safety of personnel and equipment as well as all general and local health and safety laws, codes, and procedures.

The recommendations and information contained herein are based on Eaton experience and judgement, but should not be considered to be all-inclusive or covering every application or circumstance which may arise. If any questions arise, contact Eaton for further information or instructions.

### 1. INTRODUCTION

#### General Information

The alarm (signal)/lockout switch (ASL switch) is attached to a plug-in module and is available in both single and double switch versions (see Fig. 1-1). The plug-in module is mounted in slots in the accessory mounting deck in the right pole of the circuit breaker.

The ASL switch provides remote signaling and interlocking when the circuit breaker trips. It consists of one or two single-pole, double-throw (SPDT) switches. Each SPDT switch has a make (alarm) and a break (lockout) contact; it is mounted so that the switch actuator is controlled by the circuit breaker operating mechanism trip bar.

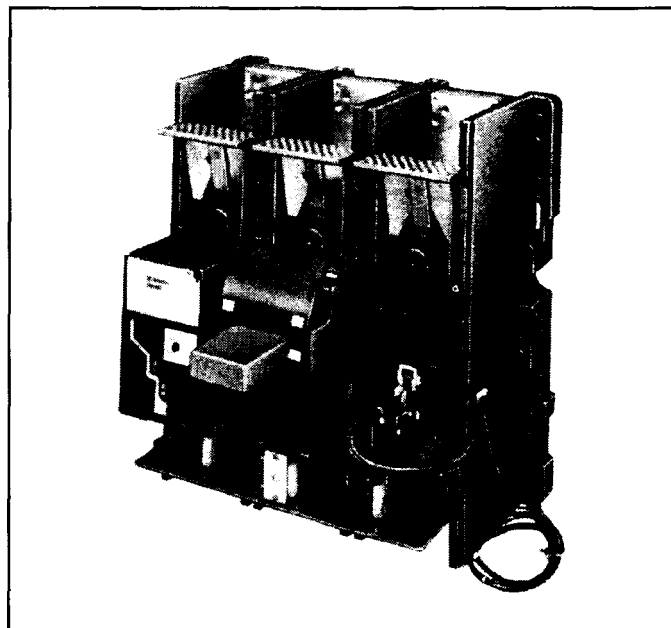

*Fig. 1-1 Alarm (Signal)/Lockout Switch Installed in R-Frame Circuit Breaker*

When the circuit breaker is in the ON or OFF position, the trip bar holds the make contact open and the break contact closed. When the circuit breaker is in the tripped position, the make contact is closed and the break contact is open. Any type of trip operation (for example, automatic trip, shunt trip, or undervoltage release) actuates the ASL switch.

Table 1-1 lists electrical ratings data for the ASL switch.

**Table 1-1. Alarm (Signal)Lockout Switch Electrical Ratings Data ①②**

Maximum Voltage (V)	Frequency	Maximum Current (A)	Dielectric Withstand Voltage (V)
600	50/60 Hz	6	2500
125	DC	0.5③	
250	DC	0.25③	

① Endurance - 500 electrical operations plus 2500 mechanical operations.

② Pigtail wire size - No. 18 AWG (0.82 mm<sup>2</sup>).

③ Noninductive load.

The standard wiring configuration for the ASL switch is pigtail leads exiting the right side of the cover. An optional

terminal block (Cat No. TBRD) may be mounted to the base on the right side of the circuit breaker to terminate attachment leads. The 18-inch (457.2mm) long pigtail leads are color coded for identification; numbered identification labels are provided for pigtail leads.

This Instruction Leaflet (IL) gives detailed procedures for installing the ASL switch.

## 2. INSTALLATION

**Note: The ASL switch can be field-installed in RD and RDC circuit breakers under UL File E64983.**

The ASL switch can be field-installed in RW and RWC circuit breakers.

The ASL switch is listed for factory installation under UL File E7819.

Before attempting to install the ASL switch, check that the catalog number is correct and the rating of the accessory satisfies the job requirements.

The ASL switch, shown in kit form in Fig. 2-1, is installed in the right pole of a 3-, or 4-pole circuit breaker.



### WARNING

---

**THE VOLTAGES IN ENERGIZED EQUIPMENT CAN CAUSE DEATH OR SEVERE PERSONAL INJURY. SPECIAL ATTENTION SHOULD BE PAID TO REVERSE FEED APPLICATIONS TO ENSURE NO VOLTAGE IS PRESENT. BEFORE MOUNTING THE ALARM (SIGNAL)/LOCKOUT SWITCH IN A CIRCUIT BREAKER INSTALLED IN AN ELECTRICAL SYSTEM, MAKE SURE THE CIRCUIT BREAKER IS SWITCHED TO THE OFF POSITION AND THERE IS NO VOLTAGE PRESENT WHERE WORK IS TO BE PERFORMED.**

**Note: Internal accessories are most easily installed in a circuit breaker before it is mounted in an electrical system. Although it is recommended that a circuit breaker mounted in an electrical system be removed to install accessories, it is possible to perform this task in a mounted circuit breaker provided no voltage is present and proper safety precautions are followed.**

2-1. Switch circuit breaker to OFF position.

**Note: To install accessory, circuit breaker must be in tripped position.**

2-2. Press PUSH-TO-TRIP button to trip operating mechanism.

**Note: The cover holds the handle in position. Attention should be paid to the orientation of the handle on the handle arm when the cover is removed. The handle must be re-installed in the same position.**

2-3. Remove cover screws, cover, and handle.

2-4. Install ASL switch as described in the following steps:

**Note: For ease of installation, auxiliary switch accessories (if used) should be installed in the accessory mounting deck before the ASL switch or other accessories.**

- a. Select position for ASL switch on accessory mounting deck (see Fig. 2-2).
- b. Place legs of ASL switch mounting bracket into slots in attachment mounting deck.
- c. Slide the ASL switch toward the line end of the circuit breaker until the retaining clip snaps into recess in deck (see Fig. 2-3).

2-5. Attach a "B" wire marking label and a numbered wire marking label to the bundle of three leads for each switch. Numbered labels are used to differentiate one ASL switch from another. Labels marked "1" through "6" are provided to permit the installation of the maximum of three 2-switch assemblies. Labels marked "B" are used to show the difference between ASL switch leads and those for the auxiliary switch. Auxiliary switch leads (when used) use the same color code but are labeled "A".



### CAUTION

---

**PIGTAIL LEADS COULD BE DAMAGED IF IN CONTACT WITH MOVING PARTS. PIGTAIL LEADS SHOULD BE FORMED AND ROUTED TO CLEAR ALL MOVING PARTS WHEN ACCESSORY IS PROPERLY INSTALLED.**

2-6. Attach cable tie mounting pad to side of circuit breaker (see Fig. 2-4 for location). Route leads to mounting pad. Ensure leads line up with slot in cover and are clear of all moving parts. Secure leads to mounting pad with cable tie. Leads from multiple accessories may be secured by a single cable tie and mounting pad (see Fig. 2-3).

2-7. Remove barrier indicated in Fig. 2-4 from cover accessory lead slot.



## CAUTION

**WHEN INSTALLING CIRCUIT BREAKER COVER, MAKE SURE THAT ALL INTERNAL PARTS ARE IN PLACE:**

- **HANDLE MUST BE HELD IN PLACE ON HANDLE ARM AS COVER IS BEING INSTALLED. LOCATE HANDLE SO THAT THE GREEN TABS ARE CLOSEST TO THE LINE-END OF THE CIRCUIT BREAKER.**

- **PIGTAIL LEADS ARE CLEAR OF COVER.**

2-8. With circuit breaker in TRIPPED position and accessory pigtail leads routed as required, install circuit breaker cover. Torque cover screws to 24 in-lbs (2.71 Nm).

2-9. Position accessory labels supplied with kit on circuit breaker as shown in Fig. 2-4.

**Note: Accessory labels show connection diagram for ASL switch contacts. Pigtail leads are color coded red, black, and blue.**

2-10. Test ASL switch by connecting continuity tester or ohmmeter across pigtail leads or terminal block connections. Check continuity as follows:

- Circuit breaker handle OFF - Check that make contact is open and break contact is closed.
- Circuit breaker handle ON - Check that make contact is open and break contact is closed.
- Press PUSH-TO-TRIP button - Check that make contact is closed and break contact is open.
- If ASL switch fails test, make sure that module is properly seated in mounting deck slots. If problem persists, contact Eaton.

2-11. Install circuit breaker.

2-12. Connect accessory leads as required (see Fig. 2-4).

Eaton assumes no responsibility for malfunctioning accessories installed improperly by the customer.

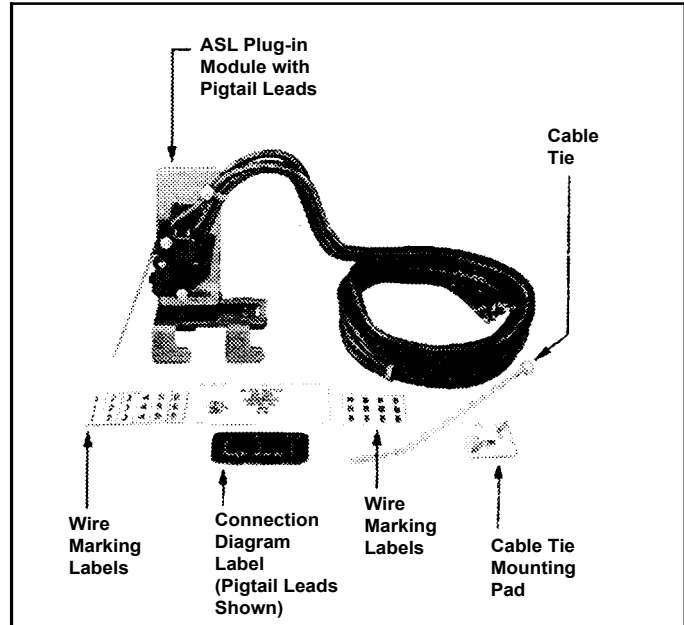

Fig. 2-1 Alarm (Signal)/Lockout Switch Kit.

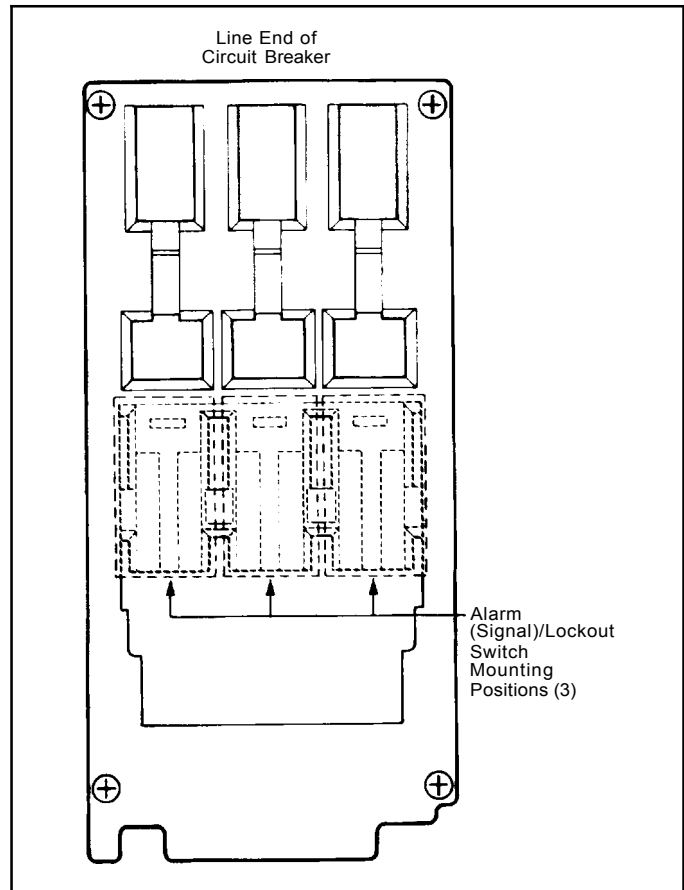

Fig. 2-2 Accessory Location Diagram.

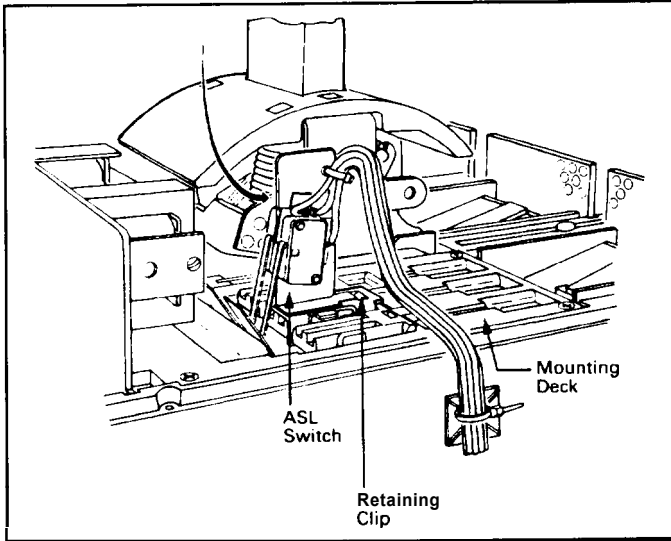

Fig. 2-3 ASL Switch Positioned and Locked in Mounting Panel.

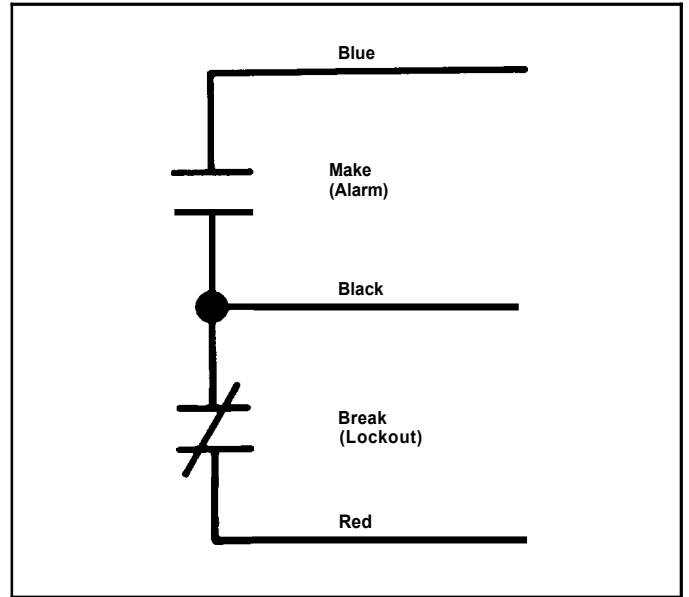

Fig. 2-5 Alarm (Signal)/Lockout Switch Connection Diagram.

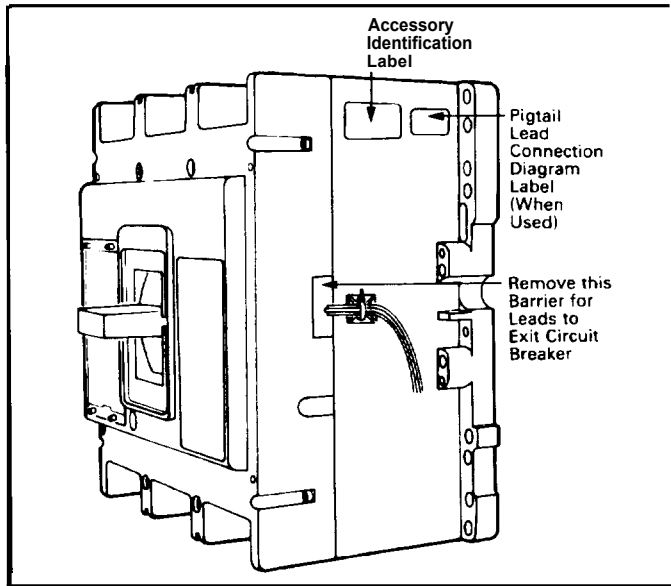

Fig. 2-4 Preferred Mounting Locations for Accessory Nameplate Labels.

**Notes:**

Installation Instructions for Alarm (Signal)/Lockout  
Switch for R-Frame Series C Circuit Breakers and  
Molded Case Switches

Instruction Leaflet IL29C185D  
Effective December 2011

**Notes:**

The instructions for installation, testing, maintenance, or repair herein are provided for the use of the product in general commercial applications and may not be appropriate for use in nuclear applications. Additional instructions may be available upon specific request to replace, amend, or supplement these instructions to qualify them for use with the product in safety-related applications in a nuclear facility.

This Instruction Booklet is published solely for information purposes and should not be considered all-inclusive. If further information is required, you should consult an authorized Eaton sales representative.

The sale of the product shown in this literature is subject to the terms and conditions outlined in appropriate Eaton selling policies or other contractual agreement between the parties. This literature is not intended to and does not enlarge or add to any such contract. The sole source governing the rights and remedies of any purchaser of this equipment is the contract between the purchaser and Eaton.

**NO WARRANTIES, EXPRESSED OR IMPLIED, INCLUDING WARRANTIES OF FITNESS FOR A PARTICULAR PURPOSE OR MERCHANTABILITY, OR WARRANTIES ARISING FROM COURSE OF DEALING OR USAGE OF TRADE, ARE MADE REGARDING THE INFORMATION, RECOMMENDATIONS, AND DESCRIPTIONS CONTAINED HEREIN.**

In no event will Eaton be responsible to the purchaser or user in contract, in tort (including negligence), strict liability or otherwise for any special, indirect, incidental or consequential damage or loss whatsoever, including but not limited to damage or loss of use of equipment, plant or power system, cost of capital, loss of power, additional expenses in the use of existing power facilities, or claims against the purchaser or user by its customers resulting from the use of the information, recommendations and description contained herein.

**Eaton Corporation**  
Electrical Sector  
1111 Superior Ave.  
Cleveland, OH 44114  
United States  
877-ETN-CARE (877-386-2273)  
Eaton.com

© 2011 Eaton Corporation  
All Rights Reserved  
Printed in USA  
Publication No. IL29C185D / TBG000817  
Part No. 6645C95H04  
December 2011