

# Instructions for LFD Current Limiter for Series C F-Frame and PD Frame 2. ELC Current Limiter for Series C F-Frame and PD Frame 2 MCPs.

## Contents

Description	Page
1. Introduction . . . . .	2
2. Installation . . . . .	2

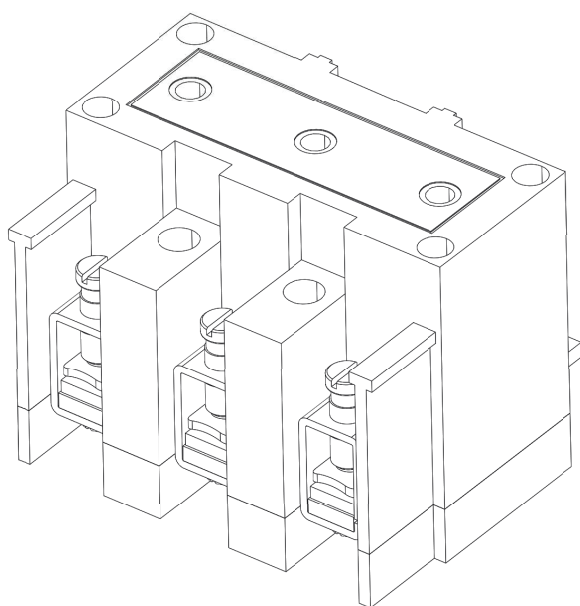

**WARNING**

DO NOT ATTEMPT TO INSTALL OR PERFORM MAINTENANCE ON EQUIPMENT WHILE IT IS ENERGIZED. DEATH, SEVERE PERSONAL INJURY, OR SUBSTANTIAL PROPERTY DAMAGE CAN RESULT FROM CONTACT WITH ENERGIZED EQUIPMENT. ALWAYS VERIFY THAT NO VOLTAGE IS PRESENT BEFORE PROCEEDING WITH THE TASK AND ALWAYS FOLLOW GENERALLY ACCEPTED SAFETY PROCEDURES. EATON IS NOT LIABLE FOR THE MISAPPLICATION OR MISINSTALLATION OF ITS PRODUCTS.

The User is cautioned to observe all recommendations, warnings, and cautions relating to the safety of personnel and equipment as well as all general and local health and safety laws, codes, and procedures.

The recommendations and information contained herein are based on Eaton experience and judgment, but should not be considered to be all-inclusive or covering every application or circumstance which may arise. If any questions arise, contact Eaton for further information or instructions.

**1. INTRODUCTION**

Current limiter circuit breaker or current limiter/MCP combinations are designed for maximum protection and coordination, and should be applied in accordance with the current limiter nameplate. For example, the LFD3150R current limiter is for use with thermal-magnetic or electronic F-Frame or PD2, whereas the ELC3030R current limiter is only to be used with the 30A MCP.

This noninterchangeability feature is made possible by combinations of molded projections and grooves and by several sizes of pierced and threaded terminals. Standard terminals are provided with the current limiter and are suitable for either copper or aluminum wire as shown in Table 1-1.

For this publication, the term circuit breaker shall also include motor circuit protector.

**Table 1-1 Current Limiter Terminals Wire Sizes**

Type ELC Current Limiter Max.Amps.	Standard Aluminum Terminals		Nonstandard Terminals (Steel)	
	Wire Range AWG(mm <sup>2</sup> )	Wire Range AWG(mm <sup>2</sup> )	Wire Range AWG(mm <sup>2</sup> )	Wire Range AWG(mm <sup>2</sup> )
50	#14-2	(2.5-35)	#14-2 <sup>②</sup>	(2.5-35)
100	#1-410	(50-95)		
150	#1-410	(50-95)		

① Terminal wire connectors are UL listed for standard wire sizes as UL 486A or 486B

② Optional on special order for copper cable only

Eaton assumes no responsibility for malfunctioning accessories installed by the customer.

A circuit breaker that is mounted in an electrical system must be removed to install the current limiter.

**Table 2-1 Clamping Screw Torque Values and Usage.**

Current Limiter Amperes	Clamping Screw	Torque value lb-in	Torque value (N•m)
25-70	#12-24	40	4.52
100-150 (also LFD3150R)	1/4-20	60 to 80	(6.78 to 9.4)

**2. INSTALLATION**

**WARNING**

IF REMOVING A CIRCUIT BREAKER INSTALLED IN AN ELECTRICAL SYSTEM, MAKE SURE THE CIRCUIT BREAKERS IS SWITCHED TO THE OFF POSITION AND THERE IS NO VOLTAGE PRESENT WHERE WORK IS TO BE PERFORMED. SPECIAL ATTENTION SHOULD BE PAID TO REVERSE FEED APPLICATIONS. THE VOLTAGES IN ENERGIZED EQUIPMENT CAN CAUSE DEATH OR SEVERE PERSONAL INJURY.

**Note :** Before attempting to install the current limiter, check that the catalog number is correct and that the rating of the accessory satisfies job requirements.

A circuit breaker that is mounted in an electrical system must be removed to install the current limiter.

2-1. Remove terminals from load end of circuit breaker.

Note: During next step, molded projections of current limiter should fit inside the molded grooves in the circuit breaker.

2-2. Position threaded terminals of current limiter under circuit breaker terminals.

2-3. Secure current limiter to circuit breaker using the three short screws and lockwashers (Table 2-1) provided in the packing envelope. Torque load screws (Table 2-1).

2-4. Secure current limiter to mounting panel using long #8-32 screws provided in the packaging envelope.

2-5. Connect cables to current limiter. Table 1-1 shows available connector types.

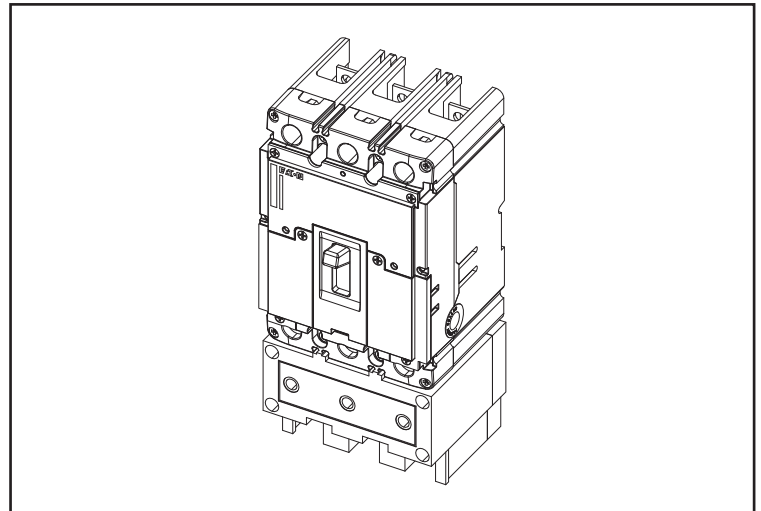

The instructions for installation, testing, maintenance, or repair herein are provided for the use of the product in general commercial applications and may not be appropriate for use in nuclear applications. Additional instructions may be available upon specific request to replace, amend, or supplement these instructions to qualify them for use with the product in safety-related applications in a nuclear facility.

This Instruction Booklet is published solely for information purposes and should not be considered all-inclusive. If further information is required, you should consult an authorized Eaton sales representative.

The sale of the product shown in this literature is subject to the terms and conditions outlined in appropriate Eaton selling policies or other contractual agreement between the parties. This literature is not intended to and does not enlarge or add to any such contract. The sole source governing the rights and remedies of any purchaser of this equipment is the contract between the purchaser and Eaton.

**NO WARRANTIES, EXPRESSED OR IMPLIED, INCLUDING WARRANTIES OF FITNESS FOR A PARTICULAR PURPOSE OR MERCHANTABILITY, OR WARRANTIES ARISING FROM COURSE OF DEALING OR USAGE OF TRADE, ARE MADE REGARDING THE INFORMATION, RECOMMENDATIONS, AND DESCRIPTIONS CONTAINED HEREIN.**

In no event will Eaton be responsible to the purchaser or user in contract, in tort (including negligence), strict liability or otherwise for any special, indirect, incidental or consequential damage or loss whatsoever, including but not limited to damage or loss of use of equipment, plant or power system, cost of capital, loss of power, additional expenses in the use of existing power facilities, or claims against the purchaser or user by its customers resulting from the use of the information, recommendations and description contained herein.

**Eaton**  
Electrical Sector  
1000 Eaton Boulevard  
Cleveland, OH 44122  
United States  
877-ETN-CARE  
(877-386-2273) Eaton.com

© 2014 Eaton  
All Rights Reserved  
Printed in USA  
Publication No. IL012348EN  
Part No. IL012348ENH01