

# Installation Instructions for E<sup>2</sup>LW Mining Service Circuit Breaker

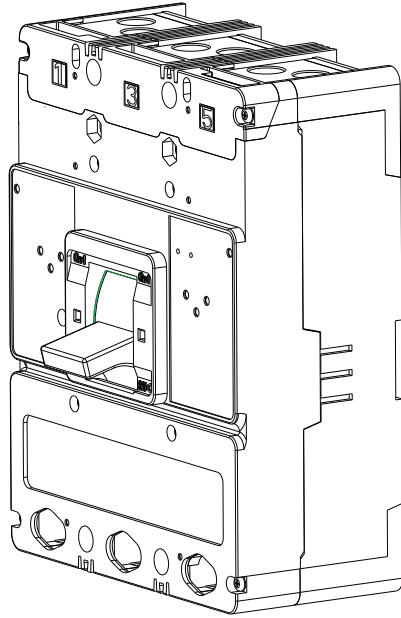

## Contents

Description	Page
1. Circuit Breaker General Information . . . . .	2
2. Installation . . . . .	3
3. Manual Operation and Thermal-Magnetic Trip Unit Adjustment . . . . .	4



*Powering Business Worldwide*

**⚠ WARNING**

**CONTACT WITH ENERGIZED EQUIPMENT CAN RESULT IN DEATH, SEVERE PERSONAL INJURY, AND SUBSTANTIAL PROPERTY DAMAGE. DO NOT ATTEMPT TO PERFORM MAINTENANCE ON EQUIPMENT WHILE IT IS ENERGIZED. ALWAYS VERIFY THAT NO VOLTAGE IS PRESENT BEFORE PROCEEDING WITH THE TASK, AND ALWAYS FOLLOW GENERALLY ACCEPTED SAFETY PROCEDURES.**

**EATON IS NOT LIABLE FOR THE MISAPPLICATION OR MISINSTALLATION OF ITS PRODUCTS.**

The user is cautioned to observe all recommendations, warnings, and cautions relating to the safety of personnel and equipment as well as all general and local health and safety laws, codes, and procedures.

The recommendations and information contained herein are based on Eaton experience and judgment, but should not be considered to be all-inclusive or covering every application or circumstance which may arise. If any questions arise, contact Eaton for further information or instructions.

**1. Circuit Breaker General Information**

The E<sup>2</sup>LW mining service circuit breaker (Fig. 1) is a 1200 Vac maximum-rated device rated for 450 A maximum continuous current. Mining service circuit breakers have been developed to meet the U.S. Federal Register ruling on trailing cable protection. This instruction leaflet (IL) gives procedures for installation and field testing of E<sup>2</sup>LW mining service circuit breaker. For this publication, mining service circuit breaker will be abbreviated to circuit breaker.

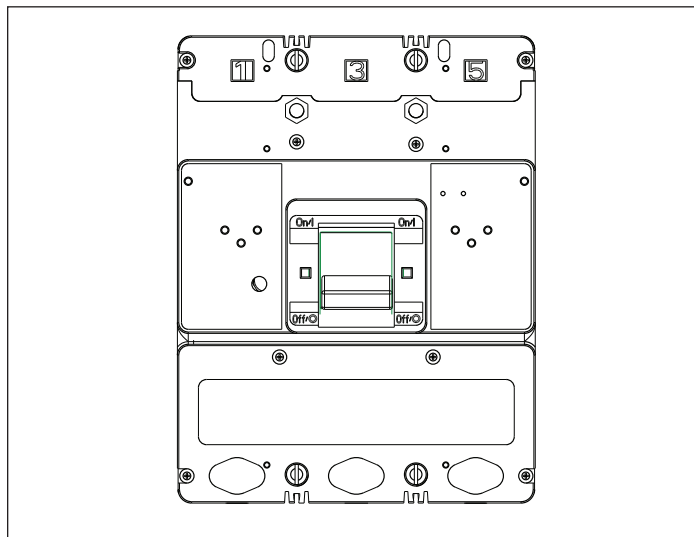

**Figure 1. E<sup>2</sup>LW Mining Service Circuit Breaker.**

**Internal Accessories:** The following types of internal accessories, which mount on the trip unit, are available for use with the circuit breaker. The number of the instruction leaflet covering the installation of the accessory is provided.

**Table 1. Internal Accessories for E<sup>2</sup>LW.**

Alarm (Signal) / Lockout (AL) Switch	IL29C183
Auxiliary Switch	IL29C123 (6633C04)
Shunt Trip	IL29C146
Low Energy Shunt Trip	IL29C147 (6633C06)
Undervoltage Release Handle w/ LED	IL29C171 (6603C60)

## 2. Installation

The installation procedure consists of inspecting the circuit breaker and, as applicable, accessories and terminals; mounting the circuit breaker; connecting the line and load conductors; torquing terminals; and installing protective barriers. To install the circuit breaker, perform the following steps.

If required, internal accessory installation in any type of circuit breaker should be done before the circuit breaker is mounted and connected. Refer to individual accessory instruction leaflets for specific installation instructions on field installable accessories.

**Note:** Circuit breaker cover can be installed or removed only if the circuit breaker is in the "TRIPPED" or "OFF" position.

Install circuit breaker cover and line terminal cover. Secure with pan-head screws. Torque to 20-22 lb-in (2.26- 2.49 Nm).

Reset circuit breaker by moving handle to the reset position. Move handle to the ON position. Circuit breaker should remain ON.

If wire connecting terminals are required, check all mounting hardware and terminal connecting hardware to correct loading. Torque values for line/load terminals are given on the name plate.

### WARNING

**THE VOLTAGES IN ENERGIZED EQUIPMENT CAN CAUSE DEATH OR SEVERE PERSONAL INJURY. BEFORE MOUNTING THE CIRCUIT BREAKER IN AN ELECTRICAL SYSTEM, MAKE SURE THERE IS NO VOLTAGE PRESENT WHERE WORK IS TO BE PERFORMED. NOT INTENDED FOR REVERSE FEED APPLICATIONS.**

Depending on the equipment configuration, the circuit breaker can be mounted using different styles of hardware. The following steps describe how to mount the circuit breaker using standard hardware.

To mount the circuit breaker, perform the following steps:

- a. Install back sheet per Fig. 2.

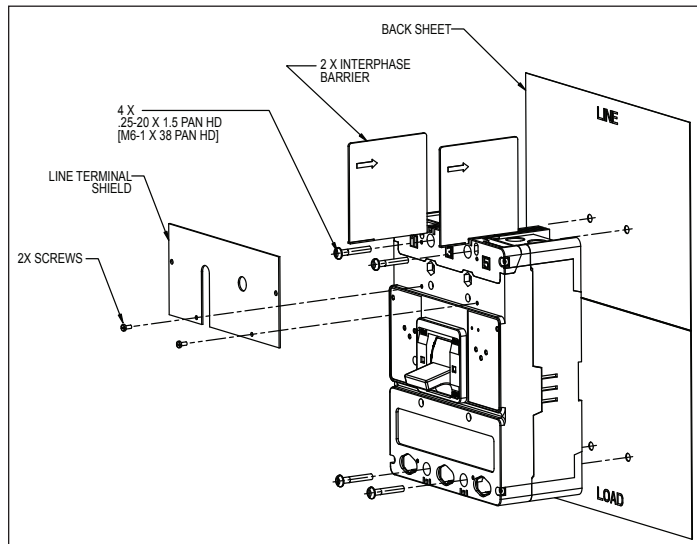

Figure 2. Installing Protective Barriers.

- b. For individual surface mounting drill mounting panel using the drilling plan shown in Fig. 3 for L-Frame. For panel-board mounting, only load end support mounting holes are required. For dead-front cover applications cut out cover to correct escutcheon dimensions (see Fig. 4).
- c. If circuit breaker includes factory or field installed internal accessories, make sure accessory wiring is accessible when the circuit breaker is mounted.

**Note:** Labels with accessory connection schematic diagrams are provided on the side of the circuit breaker.

- d. Position circuit breaker on mounting surface.
- e. Install circuit breaker mounting screws and washers. Tighten screws firmly, but do not exceed 28 lb-in. (3.2 Nm).
- f. Install the supplied interphase barriers to the LINE END of the circuit breaker by sliding the barriers into the dovetail grooves on the cover. Install the terminal shield on the circuit breaker cover with the mounting screws provided.

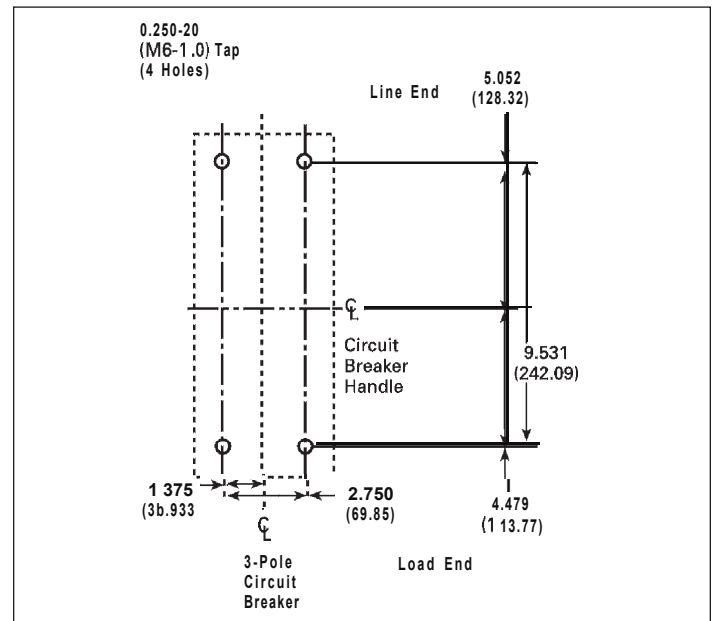

Figure 3. Mounting Bolt Drilling Plan.

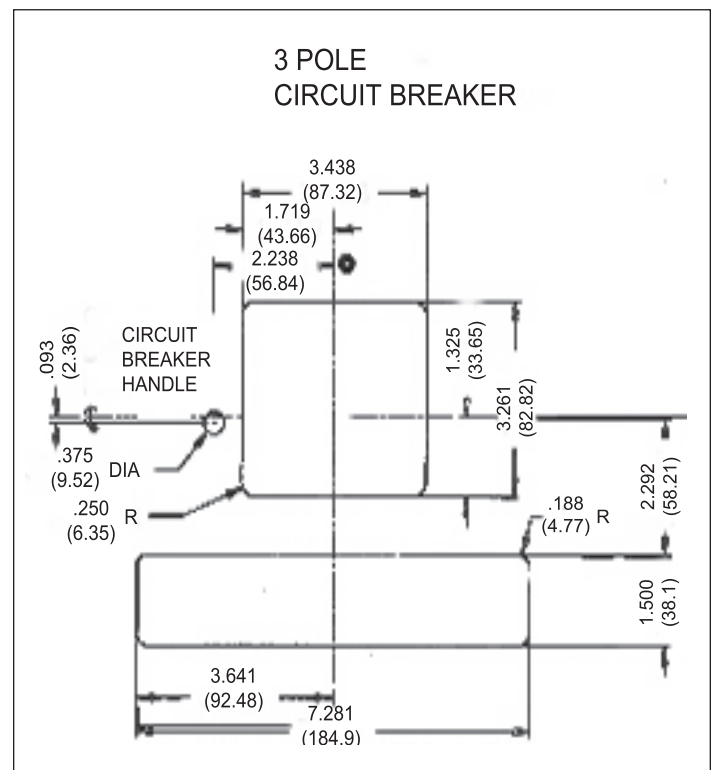

Figure 4. Escutcheon and Cutout Dimensions.

**WARNING**

**CONTACT WITH ENERGIZED EQUIPMENT CAN RESULT IN DEATH, SEVERE PERSONAL INJURY, OR SUBSTANTIAL PROPERTY DAMAGE. DO NOT ATTEMPT TO INSTALL OR PERFORM MAINTENANCE ON EQUIPMENT WHILE IT IS ENERGIZED. ALWAYS VERIFY THAT NO VOLTAGE IS PRESENT BEFORE PROCEEDING WITH THE TASK, AND ALWAYS FOLLOW GENERALLY ACCEPTED SAFETY PROCEDURES.**

Note: When replacing an existing circuit breaker of the types listed above, make sure the voltage, continuous current, and interrupting rating of the new circuit breaker are suitable.

**3 Manual Operation and Thermal-Magnetic Trip Unit Adjustment**

**Manual Operation**

Manual operation of the circuit breaker is controlled by the circuit breaker handle and the PUSH-TO-TRIP button in the trip unit. The circuit breaker handle has three positions, two of which are shown on the cover with raised lettering to indicate ON and OFF. On the handle, ON, OFF, and Trip are also shown by a color-coded strip for each circuit breaker handle position: red for ON, white for tripped, and green for OFF.

**Circuit Breaker Reset**

After a trip operation, the circuit breaker is reset by moving the circuit breaker handle to the Reset (extreme OFF) position.

Note: In the event of a thermal (overload) trip the circuit breaker cannot be reset immediately. In a breaker with a thermal-magnetic type trip unit the thermal element needs to cool (up to approximately five minutes) before it can be reset.

No circuit breaker should be reclosed until the cause of trip is known and the situation rectified.

**Push-to-Trip Button**

The Push-to-Trip button operates the circuit breaker tripping function and may be used to periodically exercise the operating mechanism. In thermal-magnetic trip units, the button is designed to be operated by a small screwdriver.

**Thermal-Magnetic Trip Unit Adjustment**

The magnetic element of each pole of the trip unit can be adjusted by rotating the adjustment buttons on the front face of the trip unit with a screwdriver. The buttons have several settings as indicated on the nameplate with values in multiples of the trip unit ampere rating (In) as shown in Figure 5.

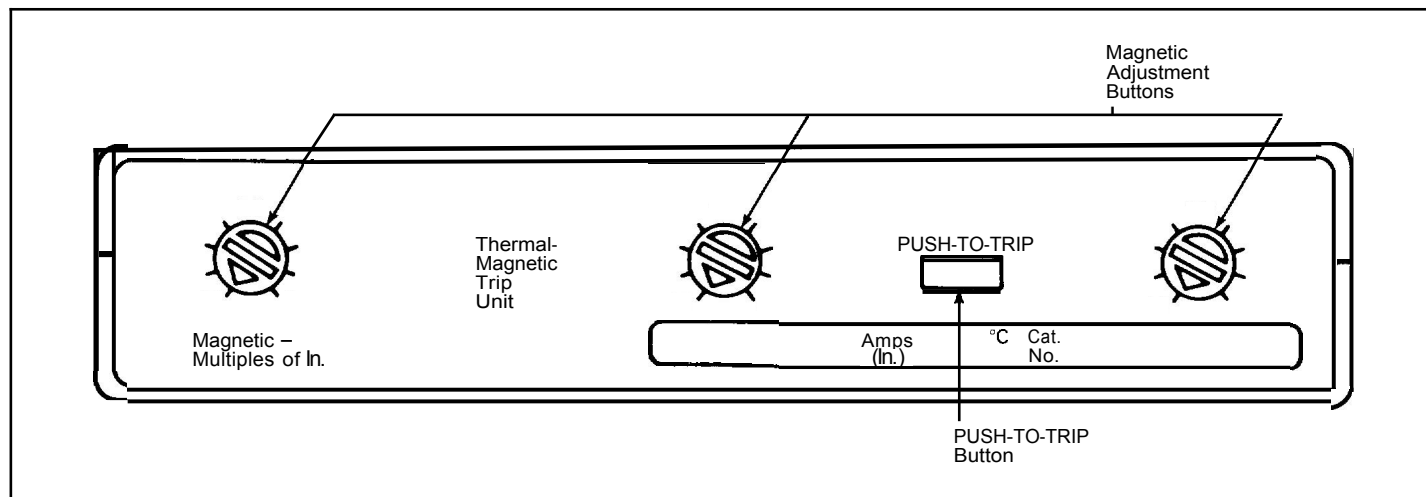

Figure 5 Trip Unit's Magnetic Adjustment Buttons.

**Notes:**

The instructions for installation and manual operation herein are provided for the use of the product in general commercial applications and may not be appropriate for use in nuclear applications. Additional instructions may be available upon specific request to replace, amend, or supplement these instructions to qualify them for use with the product in safety-related applications in a nuclear facility.

This Instruction Leaflet is published solely for information purposes and should not be considered all-inclusive. If further information is required, you should consult an authorized Eaton sales representative.

The sale of the product shown in this literature is subject to the terms and conditions outlined in appropriate Eaton selling policies or other contractual agreement between the parties. This literature is not intended to and does not enlarge or add to any such contract. The sole source governing the rights and remedies of any purchaser of this equipment is the contract between the purchaser and Eaton.

**NO WARRANTIES, EXPRESSED OR IMPLIED, INCLUDING WARRANTIES OF FITNESS FOR A PARTICULAR PURPOSE OR MERCHANTABILITY, OR WARRANTIES ARISING FROM COURSE OF DEALING OR USAGE OF TRADE, ARE MADE REGARDING THE INFORMATION, RECOMMENDATIONS, AND DESCRIPTIONS CONTAINED HEREIN.**

In no event will Eaton be responsible to the purchaser or user in contract, in tort (including negligence), strict liability or otherwise for any special, indirect, incidental or consequential damage or loss whatsoever, including but not limited to damage or loss of use of equipment, plant or power system, cost of capital, loss of power, additional expenses in the use of existing power facilities, or claims against the purchaser or user by its customers resulting from the use of the information, recommendations and description contained herein.

**Eaton**  
Electrical Sector  
1111 Superior Ave.  
Cleveland, OH 44114  
United States  
877-ETN-CARE (877-386-2273)  
Eaton.com

© 2014 Eaton  
All Rights Reserved  
Printed in USA  
Publication No. IL012022EN / TBG001106  
Part No. IL012022ENH01  
January 2014