



## Installation Instructions for Undervoltage Release Mechanism (Handle Reset) with LED for E<sup>2</sup>L and E<sup>2</sup>LM Mining Circuit Breakers



### WARNING

**CONTACT WITH ENERGIZED EQUIPMENT CAN RESULT IN DEATH, SEVERE PERSONAL INJURY, OR SUBSTANTIAL PROPERTY DAMAGE. DO NOT ATTEMPT TO INSTALL OR PERFORM MAINTENANCE ON EQUIPMENT WHILE IT IS ENERGIZED. ALWAYS VERIFY THAT NO VOLTAGE IS PRESENT BEFORE PROCEEDING WITH THE TASK, AND ALWAYS FOLLOW GENERALLY ACCEPTED SAFETY PROCEDURES.**

**CUTLER-HAMMER IS NOT LIABLE FOR THE MISAPPLICATION OR MISINSTALLATION OF ITS PRODUCTS.**

The user is cautioned to observe all recommendations, warnings, and cautions relating to the safety of personnel and equipment as well as all general and local health and safety laws, codes, and procedures.

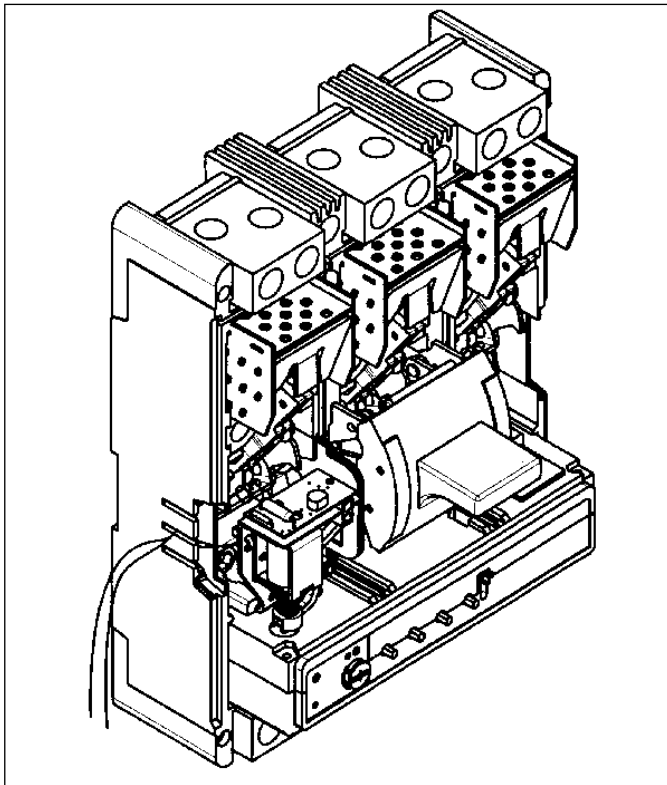

Figure 1-1 Undervoltage Release Mechanism (Handle Reset) with LED installed in L-Frame Mining Circuit Breaker

The recommendations and information contained herein are based on Cutler-Hammer experience and judgment, but should not be considered to be all-inclusive or covering every application or circumstance which may arise. If any questions arise, contact Cutler-Hammer for further information or instruction.

### 1.0 INTRODUCTION

#### General Information

The undervoltage release mechanism (UVR) (Figure 1-1) monitors a voltage (typically a line voltage and trips the circuit breaker when the voltage falls to between 70 and 35 percent of the solenoid coil rating. The UVR consists of a continuous rated solenoid with a plunger and reset lever assembled to a plug-in module. The plug-in module is mounted in slots in the top of the trip unit and occupies the accessory cavity in the circuit breaker frame. The reset lever resets the UVR when normal voltage is restored and the circuit breaker handle is moved to the resets (extreme OFF) position. With no voltage applied to the UVR, the circuit breaker contacts will not touch when a closing operation is attempted.

The UVR is available for 120 VAC. Table 1.1 lists applications and electrical ratings data for the UVR.

For this publication, the term circuit breaker shall also include molded case switch and motor circuit protector.

Depending on the model ordered, connections for the UVR are in one of four forms. The standard wiring configuration is pigtail leads exiting the rear of the base directly behind the UVR. Optional configurations include a terminal block mounted on the same side of the base as the accessory, leads exiting the side of the base where the accessory is mounted, and leads exiting the rear of the base on the side opposite the accessory. The 18-inch long pigtail leads are color coded for identification; identification labels are provided for pigtail leads and terminal block points.

This instruction leaflet (IL) gives detailed procedures for installing the UVR.

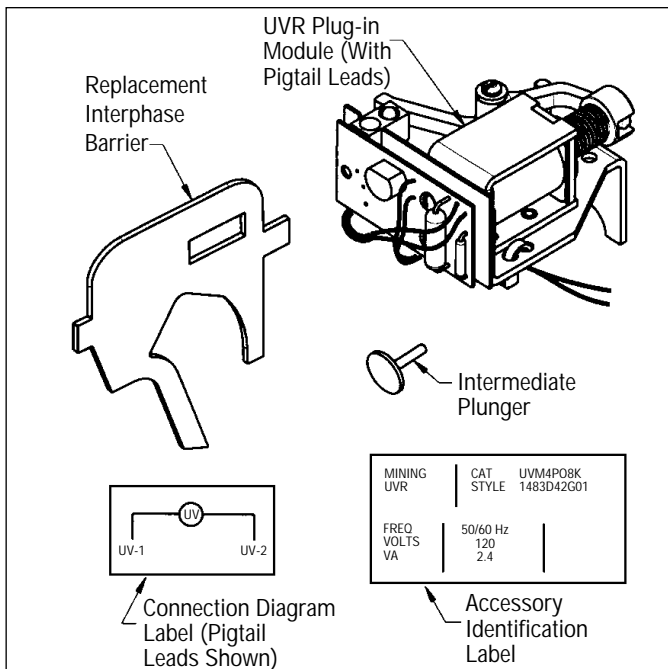

Figure 2-1 Undervoltage Release Mechanism (Handle Reset) Kit

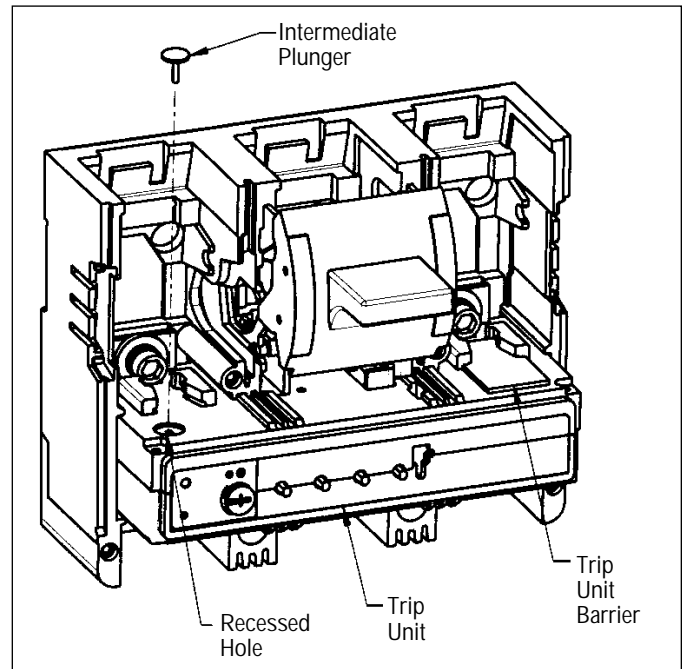

Figure 2-2 Trip Unit Barrier Removal

2.0 INSTALLATION

**NOTICE**

The UVR can be field-installed in E<sup>2</sup>L and E<sup>2</sup>LM min-ing circuit breakers.

Before attempting to install the UVR, check that the catalog number is correct as ordered.

The UVR, shown in kit form in Figure 2-1, is installed in the left accessory mounting cavity of a 3-pole circuit breaker. A UVR must be installed in the circuit breaker before the circuit breaker is mounted in an electrical system. To install the UVR, perform the following procedures:

**NOTICE**

A circuit breaker that is mounted in an electrical system must be removed to install the accessory. To ensure correct accessory installation, the circuit breaker must be placed on a horizontal surface.



**WARNING**

THE VOLTAGES IN ENERGIZED EQUIPMENT CAN CAUSE DEATH OR SEVERE PERSONAL INJURY. SPECIAL ATTENTION SHOULD BE PAID TO REVERSE FEED APPLICATIONS TO ENSURE NO VOLTAGE IS PRESENT. BEFORE REMOVING A CIRCUIT BREAKER INSTALLED IN AN ELECTRICAL SYSTEM, MAKE SURE THE CIRCUIT BREAKER IS SWITCHED TO THE OFF POSITION AND THERE IS NO VOLTAGE PRESENT WHERE WORK IS TO BE PERFORMED.

**NOTICE**

For new circuit breaker installation, the trip unit must be installed in circuit breaker before attempting to install a UVR. Refer to I.L. 29C607, I.L. 29C608, I.L. 29C609 or I.L. 29C610 for instructions on how to install trip unit.

- 2-1. Switch circuit breaker to OFF position.

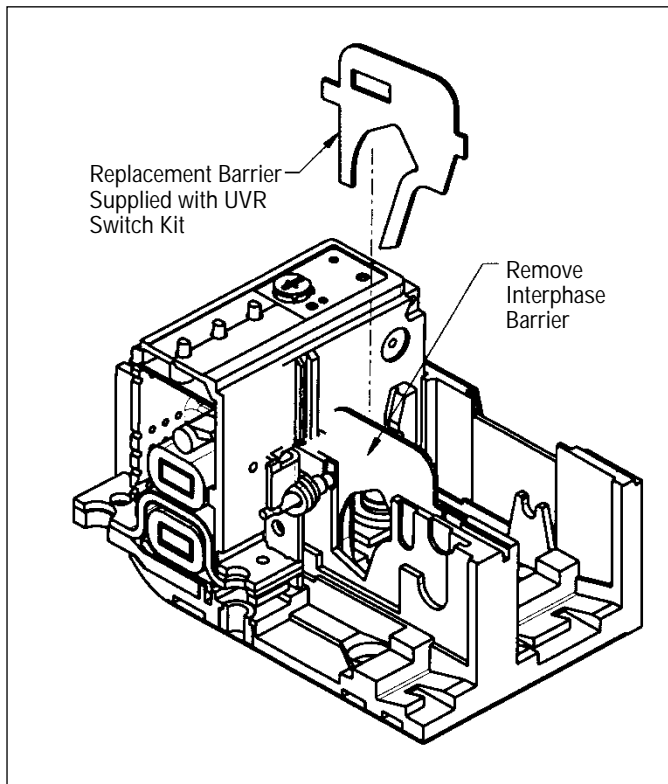

Figure 2-3 Interphase Barrier Replacement

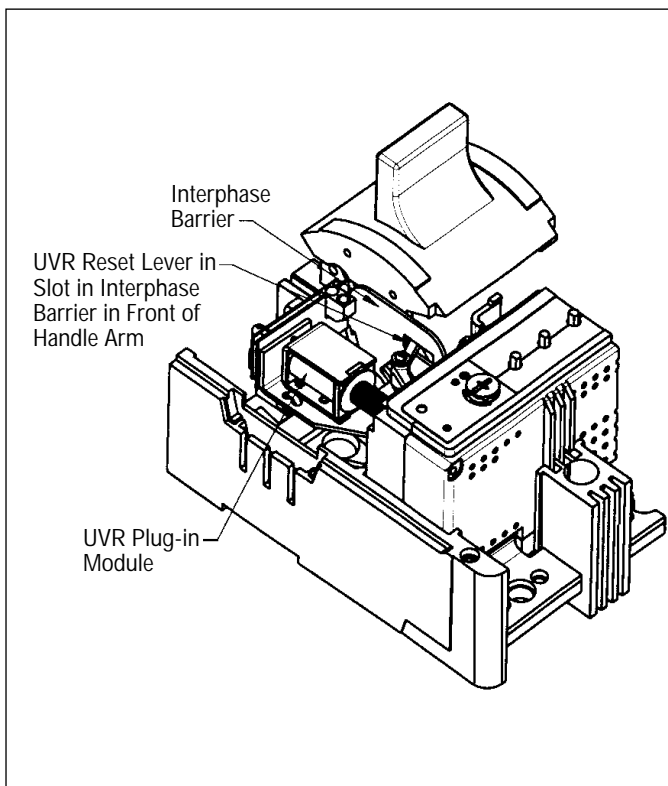

Figure 2-4 UVR Installation

## NOTICE

**To install UVR, circuit breaker operating mechanism must be in tripped position.**

Molded case switch trip units are not equipped with a Push-to-Trip button. For molded case switches, omit step 2-3.

- 2-2. Disconnect and remove circuit breaker from installation and terminal connections.
- 2-3. Press PUSH-TO-TRIP button to trip operating mechanism, and check handle moves to trip position with white colored indicator visible in escutcheon window.
- 2-4. Remove circuit breaker cover screws and covers.
- 2-5. For high instantaneous trip-type (catalog suffix K designation) molded case switches, find recessed hole in either of the trip unit outer poles (Figure 2-2). Push intermediate plunger supplied with UVR in one hole to trip the molded case switch. Remove plunger to prevent it falling out of recessed hole in trip unit and into molded case switch mechanism.
- 2-6. Remove interphase barrier between accessory mounting cavity and operating mechanism (see Figure 2-3).
- 2-7. Install replacement interphase barrier (supplied with kit) in base (see Figure 2-3).
- 2-8. Install UVR as described in following steps (see Figure 2-4).



## WARNING

**IF UVR IS REMOVED FROM CIRCUIT BREAKER, INTERMEDIATE PLUNGER MUST ALSO BE REMOVED. FAILURE TO REMOVE THE INTERMEDIATE PLUNGER CAN RESULT IN EQUIPMENT DAMAGE.**

- a. Remove barrier from trip unit accessory mounting slots in pole being used for accessory (Figure 2-2).
- b. Position intermediate plunger in trip unit (Figure 2-2).
- c. Press intermediate plunger into recess in trip unit and hold in position.

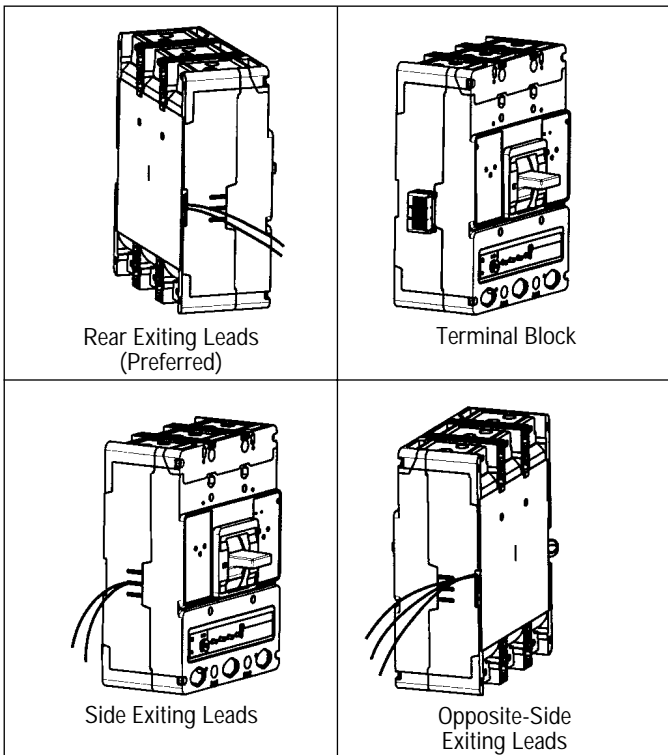

Figure 2-5 Accessory Wiring Options

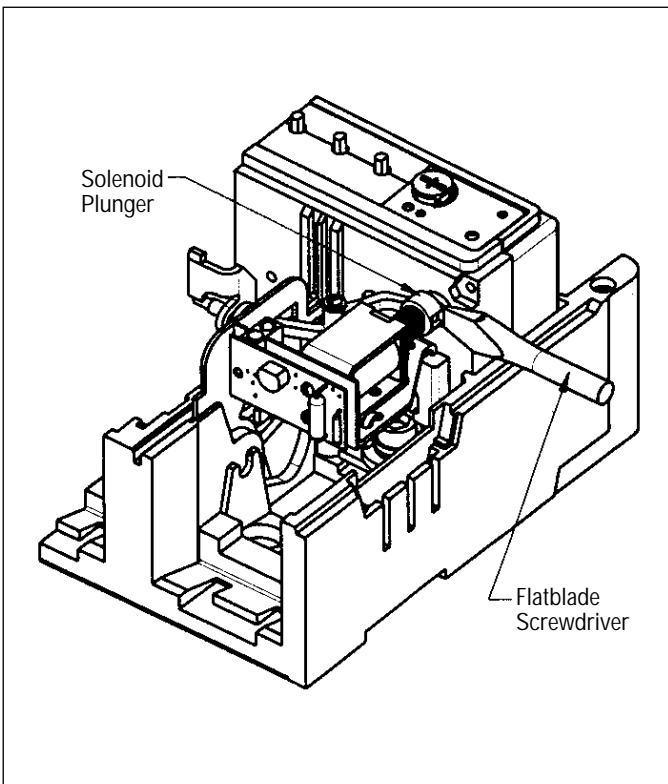

Figure 2-6 Screwdriver Depressing Undervoltage Release Mechanism Solenoid Plunger

- d. Push circuit breaker handle towards the ON position and hold while sliding UVR plug-in module into slots in trip unit (Figure 2-4) until retaining clip snaps into trip unit. For terminal block assemblies, slide terminal block into mounting slot on side of base as plug-in module is being positioned.

## NOTICE

For a UVR having rear or opposite-side exiting pigtail leads, thread leads through in side of base before attempting to insert the mounting bracket. Pigtail leads exiting in this manner should be eased through trough as mounting bracket is inserted into trip unit retaining slots. Use center trough also for leads exiting the side of the circuit breaker.

**LEADS SHOULD BE FORMED AND ROUTED TO CLEAR ALL MOVING PARTS WHEN ACCESSORY IS PROPERLY INSTALLED. PIGTAIL WIRES COULD BE DAMAGED IF IN CONTACT WITH MOVING PARTS.**

- 2-9. Route wiring to meet installation requirements (Figure 2-5). If required, complete routing of leads of opposite side through rear wiring trough.



## WARNING

**FAILURE TO KEEP FINGERS AWAY FROM MOVING PARTS CAN CAUSE PERSONAL INJURY. WHEN CHECKING ACCESSORY, DO NOT PUT FINGERS NEAR MOVING PARTS INSIDE CIRCUIT BREAKER CASE. SPRINGS CAUSE INTERNAL PARTS TO MOVE QUICKLY AND WITH FORCE.**

- 2-10. Perform mechanical check of UVR after installation:
  - a. With the circuit breaker still electrically isolated, reset the circuit breaker.
  - b. Mechanical check. Using a small flat-blade screwdriver, (Figure 2-6), push in and hold solenoid plunger. Switch circuit breaker to ON. Release solenoid plunger and check that circuit breaker trips.
  - c. Reset circuit breaker handle and check that handle arm moves reset lever to reset the solenoid plunger.
  - d. If mechanical check does not trip circuit breaker, see if UVR and intermediate plunger are correctly installed. If UVR and intermediate plunger are cor-

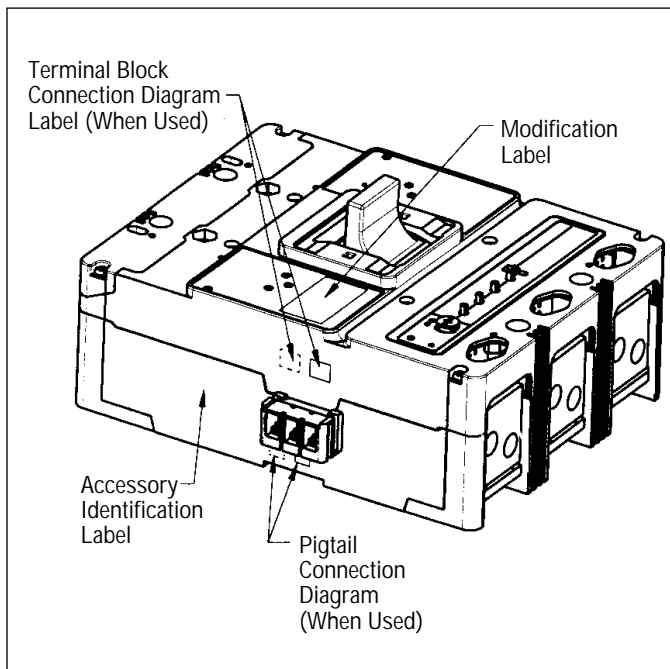

Figure 2-7 Preferred Mounting Locations for Accessory Nameplate Labels

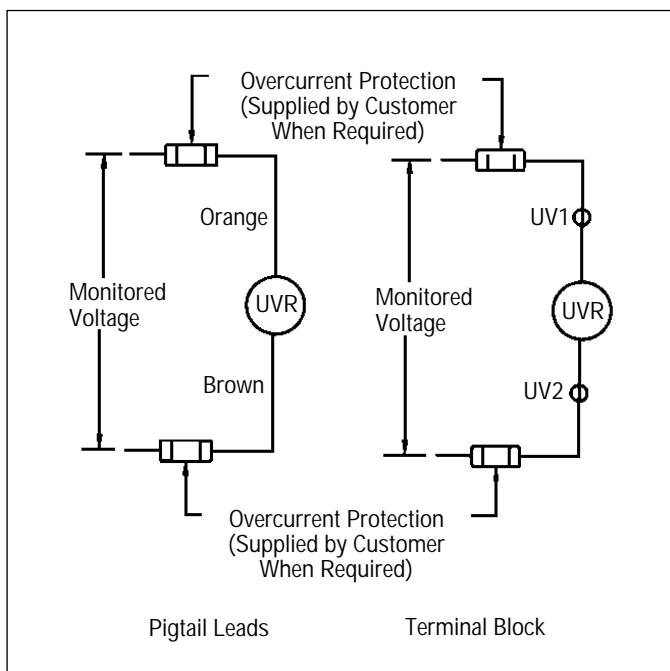

Figure 2-8 Undervoltage Release Mechanism (Handle Reset) Connection Diagram

rectly installed. If UVR and intermediate plunger appear to be properly installed and problem persists, contact Cutler-Hammer.



**CAUTION**

**WHEN INSTALLING CIRCUIT BREAKER MAIN COVER, MAKE SURE THAT ALL INTERNAL PARTS ARE IN PLACE:**

- **SLIDING HANDLE BARRIER IS POSITIONED SO THAT THE HANDLE OPENING IS ALIGNED WITH THE HANDLE.**
- **ALL LEADS ARE CLEAR OF THE COVER.**

2--11. With circuit breaker handle in the TRIPPED position and accessory pigtail leads (if used) routed as required, install circuit breaker covers. Secure with pan-head screws. Torque to 20-22 lb-in. (2.26-2.49 N.m.)

2-12. Remove and discard UL listing label on LDB circuit breakers only.

2-13. Place accessory labels (supplied with kit) on circuit breaker (see Figure 2-7).

2-14. Where practical and after taking all necessary safety precautions, apply rated voltage to UVR. Reset and close circuit breaker. Confirm that circuit breaker trips when voltage is removed.

**NOTICE**

**Accessory labels show connection diagram for UVR contacts. Pigtail leads are color coded orange and brown.**

2-16. Connect UVR as required (see Figure 2-8).

Cutler-Hammer assumes no responsibility for malfunctioning accessories installed improperly by the customer.

Table 1.1 AC (50/60 Hz) Undervoltage Release Mechanism (Handle Reset) Ratings ①

Application Ratings	Electrical Operating Ratings					Approximate Operating Time (ms)			
	Voltage (V)	Supply Voltage (V)	Dropout Voltage (V) Min.	Min.	Pickup Voltage (V) Max.	VA	Min.② UVR Response	Initiation③ Circuit Breaker Contact Separation	Maximum Circuit Breaker Contact Opening
120	120	44.5	77	93.5	2.1	5	15	25	1500

① Endurance – 400 electrical operations plus 5600 mechanical operations

② UVR will override a momentary voltage dip up to the response time shown

③ Unlatching occurs 1 millisecond before circuit breaker contacts begin to separate

④ For 1 minute



## Cutler-Hammer

Five Parkway Center  
Pittsburgh, PA 15220

---

Effective 3/98 (ISI)  
Style 6603C60H01  
Printed in U.S.A.

