

Installation Instructions For HJDDC Circuit Breaker and Molded Case Switch

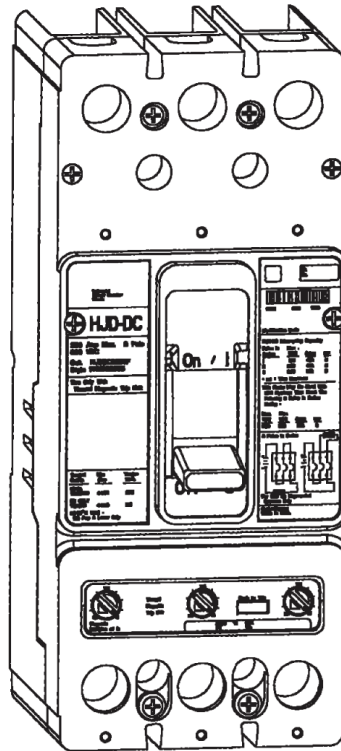

Contents

Description	Page
Introduction	2
Installation	3
Manual Operation and Thermal-Magnetic Adjustment	5
Inspection and Field Testing	6

⚠ WARNING

DO NOT ATTEMPT TO INSTALL OR PERFORM MAINTENANCE ON EQUIPMENT WHILE IT IS ENERGIZED. DEATH, SEVERE PERSONAL INJURY OR SUBSTANTIAL PROPERTY DAMAGE CAN RESULT FROM CONTACT WITH ENERGIZED EQUIPMENT. ALWAYS VERIFY THAT NO VOLTAGE IS PRESENT BEFORE PROCEEDING WITH THE TASK, AND ALWAYS FOLLOW GENERALLY ACCEPTED SAFETY PROCEDURES.

EATON IS NOT LIABLE FOR THE MISAPPLICATION OR MISINSTALLATION OF ITS PRODUCTS.

The user is cautioned to observe all recommendations, warnings, and cautions relating to the safety of personnel and equipment as well as all general and local health and safety laws, codes, and procedures.

1. Introduction

General Information

In this document, the term circuit breaker includes molded case switches. The J-frame Series C circuit breaker (**Fig.1**) type HJDDC is rated 600 Vdc maximum and from 70A to 250A continuous current using type JT thermal-magnetic trip units. (Refer to **Table 1** for all available trip unit ratings.) The circuit breaker is listed in accordance with Underwriters Laboratories, Inc. Standard UL489. The type HJDDC circuit breaker is for use in grounded and ungrounded applications where multiple poles are connected in series (**Figures 2—5**). A 3-pole breaker may be wired as a 2-pole with rated voltage and interruption based on the number of poles wired in series. For grounded isolated load configurations, the interruption rating is based on number of poles in series that break the ungrounded leg of the power supply.

This instruction leaflet (IL) gives procedures for installation and field testing of the type HJDDC Series C DC circuit breaker.

Table 1. Available Trip Unit Ratings.

Circuit Breaker Types	Trip Unit Types Thermal Magnetic Amperes I_n	
	Fixed Thermal	Adjustable Magnetic Multiples of I_n ①
HJDDC	70 90 100 125 150 175 200 225 250	5 to 10

① For adjustable thermal trip units, the magnetic setting is a multiple of the maximum thermal setting. For Vdc applications, the magnetic tripping values may exceed the Vac values by 42%.

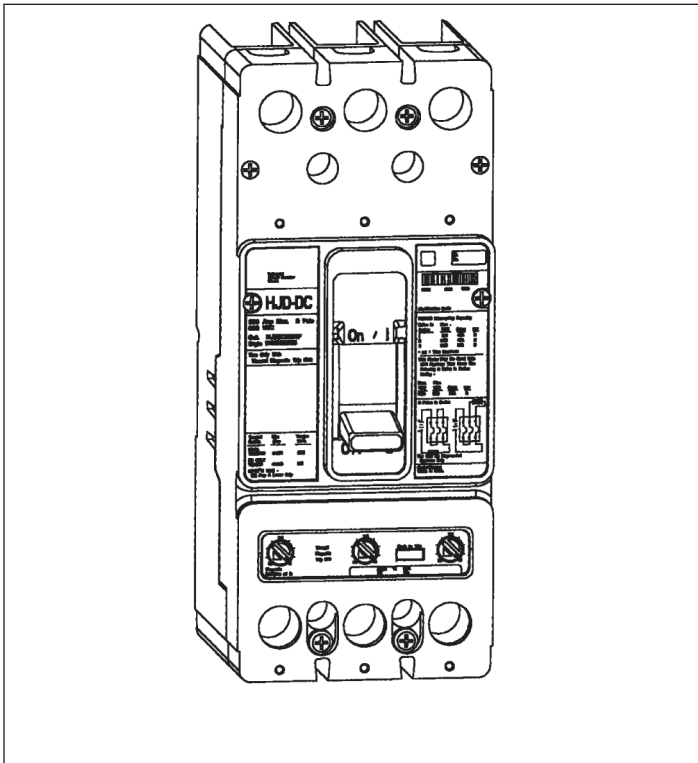

Figure 1. Type HJDDC Series C DC Circuit Breaker with JT Trip Unit Installed.

The recommendations and information contained herein are based on Eaton experience and judgement, but should not be considered to be all-inclusive or covering every application or circumstance which may arise. If any questions arise, contact Eaton for further information or instructions.

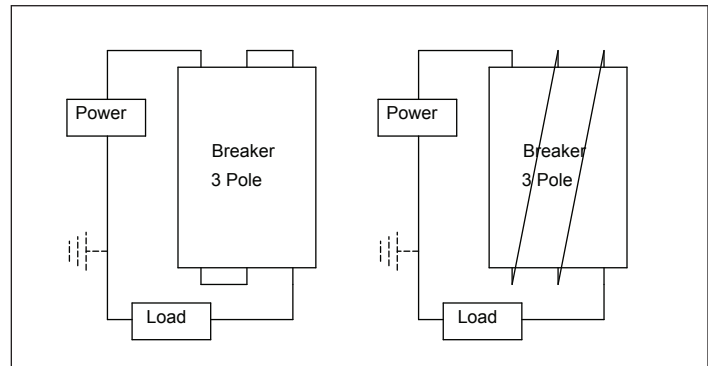

Figure 2. Load Connected to Power Source. Grounded or Ungrounded Systems.

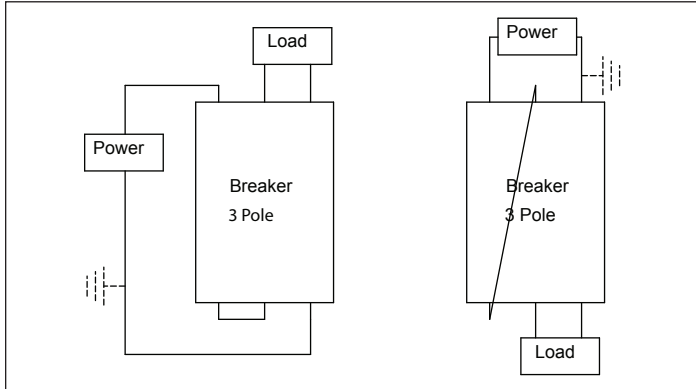

Figure 3. Load Isolated from Power Source. Grounded or Ungrounded Systems. If System Voltage Exceeds 300 Vdc, then Ungrounded Systems Only.

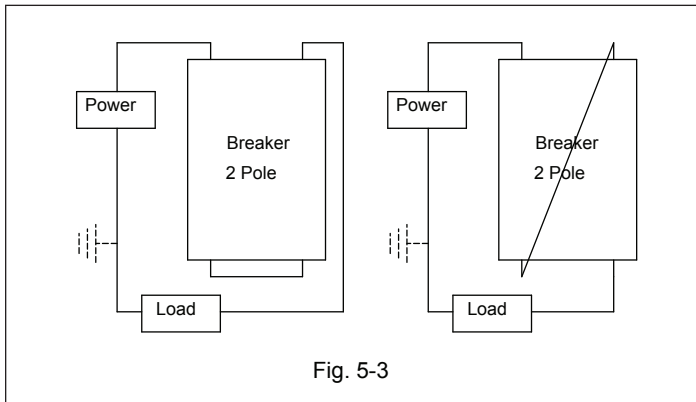

Fig. 5-3

Figure 4. Load Connected to Power Source. Grounded or Ungrounded Systems.

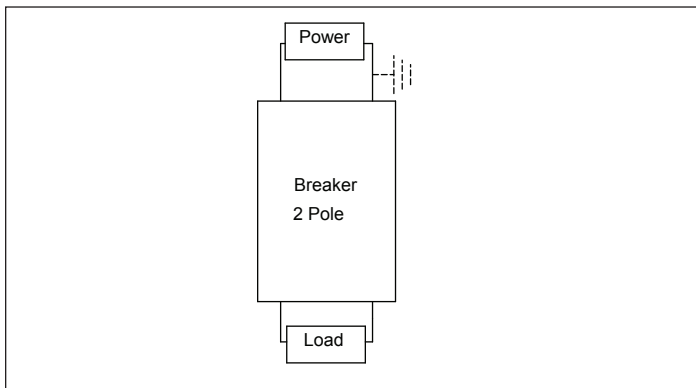

Figure 5. Load Isolated from Power Source. Grounded or Ungrounded Systems. If System Voltage Exceeds 125 Vdc, then Ungrounded Systems Only.

2. Installation

The installation procedure consists of inspecting the circuit breaker and, as applicable, installing the trip unit, accessories, interphase barriers and terminals; mounting the circuit breaker; connecting the line and load conductors; torquing terminals; and attaching terminal shields. Circuit breaker frames, trip units, accessories, mounting hardware, and unmounted terminals may be supplied in separate packages. To install the circuit breaker, perform the following steps.

If required, internal accessory installation in any type of circuit breaker should be done before the circuit breaker is mounted and connected. Refer to individual accessory instruction leaflets.

2-1. Make sure that the circuit breaker frame is suitable for the intended installation by comparing name-plate data with existing ratings and system requirements. Inspect the circuit breaker for completeness, and check for damage before mounting. Uninstalled cover mounting hardware is supplied in a plastic bag with the circuit breaker frame (**Fig. 6**).

2-2. Remove installed cover screws and cover.

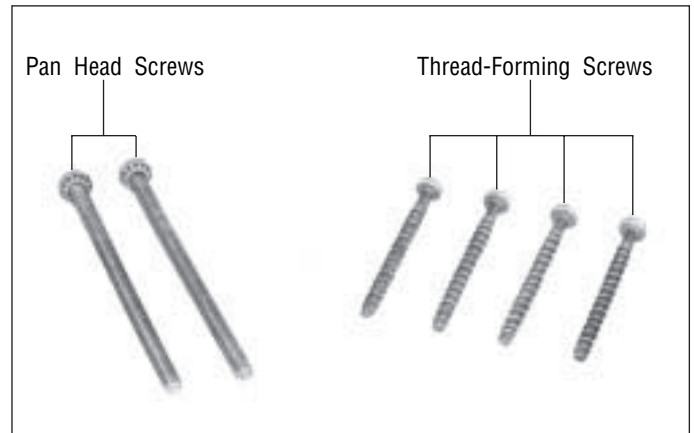

Figure 6. Cover Mounting Hardware.

NOTICE

INSTRUCTIONS FOR INSTALLING THE TRIP UNIT AND ACCESSORIES IN THE J-FRAME CIRCUIT BREAKER ARE SUPPLIED WITH EACH ITEM.

2-3. If not already installed, mount trip unit and accessories (if required) in circuit breaker frame.

CAUTION

WHEN REMOVED AND REINSTALLED, THREAD-FORMING SCREWS WILL TRY TO REFORM THE THREADS IN THE BASE. CARE SHOULD BE TAKEN EVERY TIME A THREAD-FORMING SCREW IS USED TO ENSURE THE SCREW STARTS IN THE ORIGINAL THREADS. DAMAGED THREADS CAN RESULT IN IMPROPER CIRCUIT BREAKER COVER RETENTION.

2-4. Install cover, and secure with pan-head screws followed by thread-forming screws, as shown in (Fig. 7). Torque the cover screws to 18-23 lb-in (2-2.6 Nm).

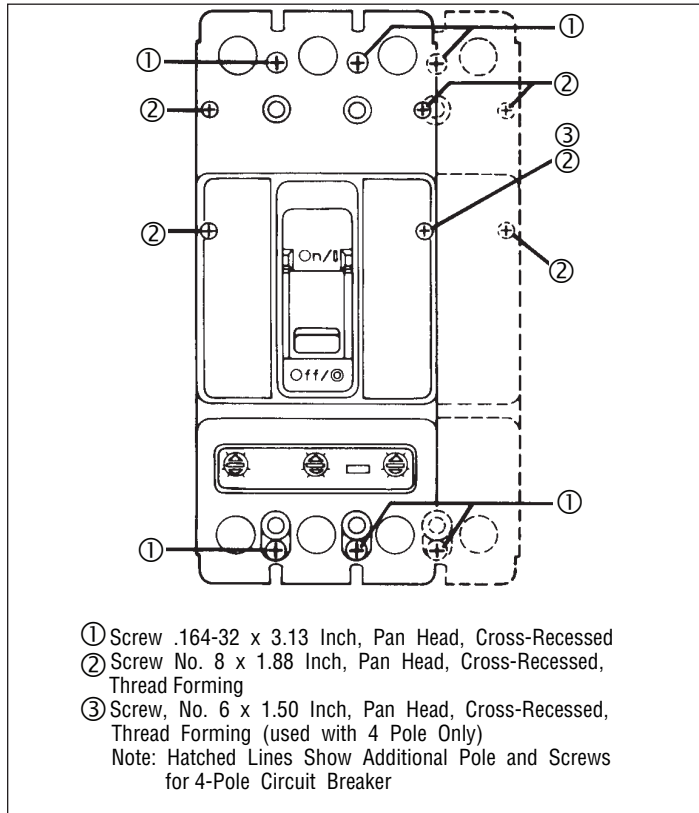

Figure 7. Cover Screw Installation Positions.

2-5. If not already installed, mount terminals as shown in (Fig. 8). When using terminal (Catalog No. TA250KB), secure the terminal to the circuit breaker using a 5/32-inch socket wrench and torque to 6-8 lb-ft (8-11 N.m). After mounting the circuit breaker and before installation of the conductors, the terminal mounting screw can be checked or retightened through the terminal when the conductor screw is removed. When using terminal (Catalog No. T250KB), secure the terminal to the circuit breaker using screw and nut. Torque to 7-9 Lb-in (0.8-1 N.m.).

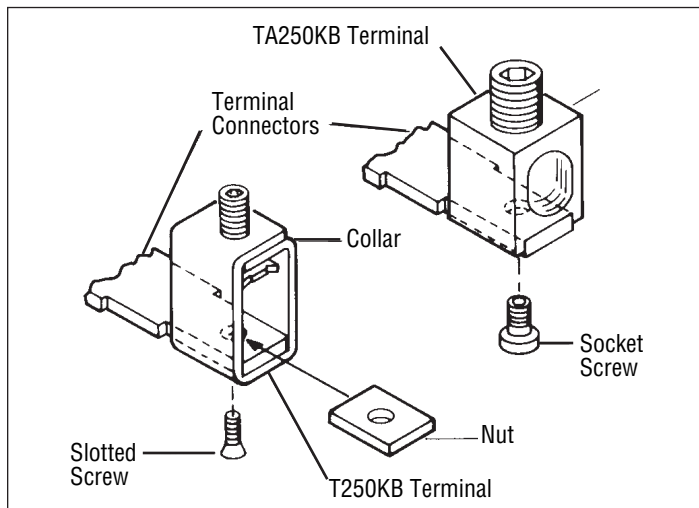

Figure 8. Terminal Installation.

⚠ WARNING

BEFORE MOUNTING THE CIRCUIT BREAKER IN AN ELECTRICAL SYSTEM, MAKE SURE THERE IS NO VOLTAGE PRESENT WHERE WORK IS TO BE PERFORMED. SPECIAL ATTENTION SHOULD BE PAID TO REVERSE FEED APPLICATIONS TO ENSURE NO VOLTAGE IS PRESENT. THE VOLTAGES IN ENERGIZED EQUIPMENT CAN CAUSE DEATH OR SEVERE PERSONAL INJURY.

NOTICE

DEPENDING ON THE EQUIPMENT CONFIGURATION, THE CIRCUIT BREAKER CAN BE MOUNTED USING DIFFERENT STYLES OF HARDWARE. THE FOLLOWING STEPS DESCRIBE HOW TO MOUNT THE CIRCUIT BREAKER USING STANDARD HARDWARE. WHEN SPECIAL HARDWARE IS NEEDED (FOR EXAMPLE, WITH THE ELECTRICAL OPERATOR), THE INSTRUCTION LEAFLET DESCRIBING THE ACCESSORY ALSO DESCRIBES THE SPECIAL MOUNTING ARRANGEMENTS.

2-6. To mount the circuit breaker, perform the following steps:

- a. For individual surface mounting, drill mounting panel using the drilling plan shown in (Fig. 9). For panelboard mounting, only load end support mounting holes are required. For dead front cover applications, cut out cover to correct escutcheon dimensions (Fig. 10).

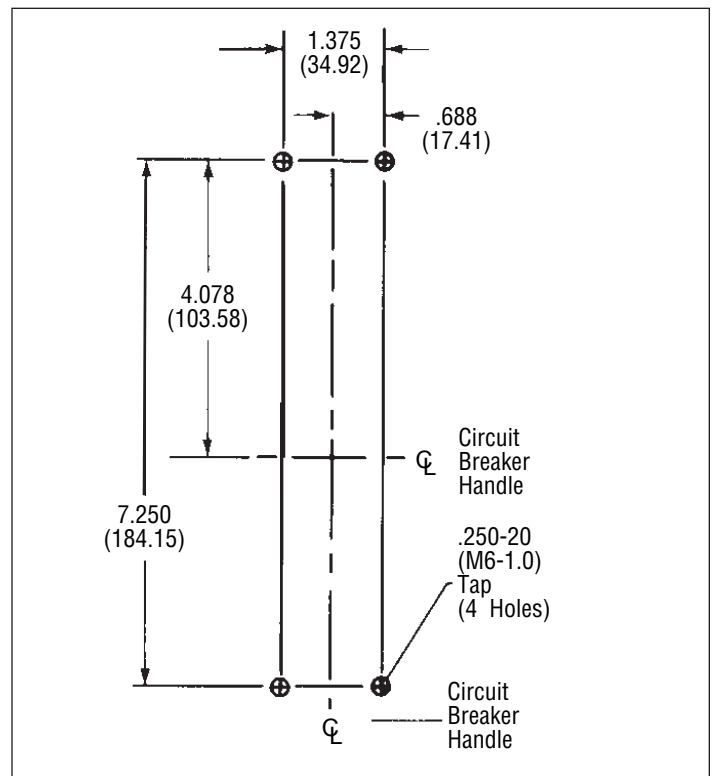

Figure 9. Circuit Breaker Mounting Bolt Drilling Plans.

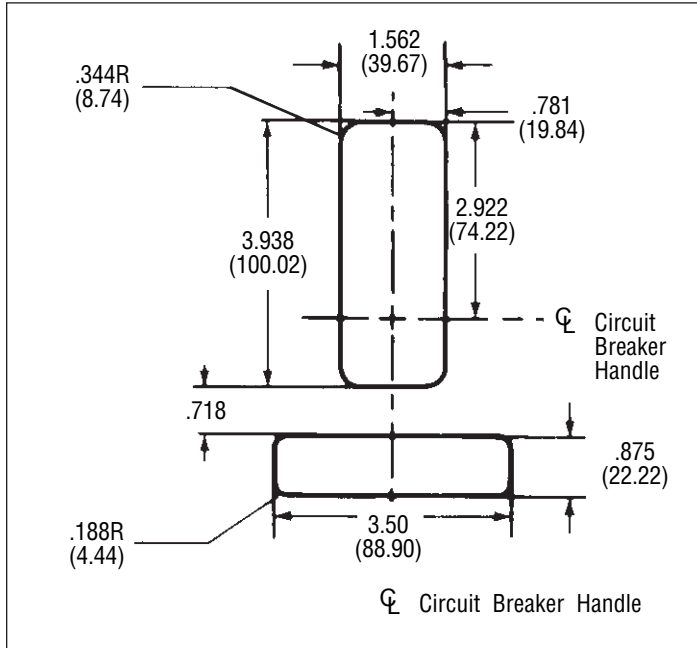

Figure 10. Circuit Breaker Escutcheon Dimensions.

- b. If circuit breaker includes factory- or field-installed internal accessories, make sure that accessory wiring can be reached when the circuit breaker is mounted.

NOTICE

LABELS WITH ACCESSORY CONNECTION SCHEMATIC DIAGRAMS ARE PROVIDED ON THE SIDE OF THE CIRCUIT BREAKER. A NOTE SHOULD BE MADE OF THE DIAGRAMS IF THE LABELS CANNOT BE SEEN WHEN THE CIRCUIT BREAKER IS MOUNTED.

- c. Position circuit breaker on mounting surface.
- d. Install circuit breaker mounting screws and washers. Tighten screws firmly, but do not exceed 28 pound-inches (3 N.m.).

CAUTION

WHEN ALUMINUM CONDUCTORS ARE USED, THE APPLICATION OF A SUITABLE JOINT COMPOUND IS RECOMMENDED TO REDUCE THE POSSIBILITY OF TERMINAL OVERHEATING. OVERHEATING CAN CAUSE NUISANCE TRIPPING AND DAMAGE TO THE CIRCUIT BREAKER.

- 2-7. Connect line and load conductors and accessory leads.
- 2-8. If required, install terminal shield on circuit breaker cover with mounting screws provided.
- 2-9. After the circuit breaker is installed, check all mounting hardware and terminal connecting hardware for correct torque loading. Torque values for line/load terminals are given in **Table 2** and on the circuit breaker nameplate.

Table 2. Terminal Types

Terminal Catalog Number	Terminal Material Body	Screw Head Type	AWG Wire Range	Metric Wire Range	Wire Type	Torque Value lb-in (N.m.)
T250KB	Stainless Steel	Socket	4-350 MCM	25-150	Cu	180 (20)
TA250KB	Aluminum	Socket	4-350 MCM	25-150	Cu/Al	275 (31)

3. Manual Operation and Thermal-Magnetic Adjustment

Manual Operation

Manual operation of the circuit breaker is controlled by the circuit breaker handles and the PUSH-TO-TRIP button in the trip unit. The circuit breaker handle has three positions, two of which are shown on the cover with raised lettering to indicate ON and OFF. On the sliding handle barrier, ON, OFF, and trip are also shown by a color-coded strip for each circuit breaker handle position: red for ON, white for tripped, and green for OFF. ON/OFF is also shown with the international symbols I/O (Fig. 11).

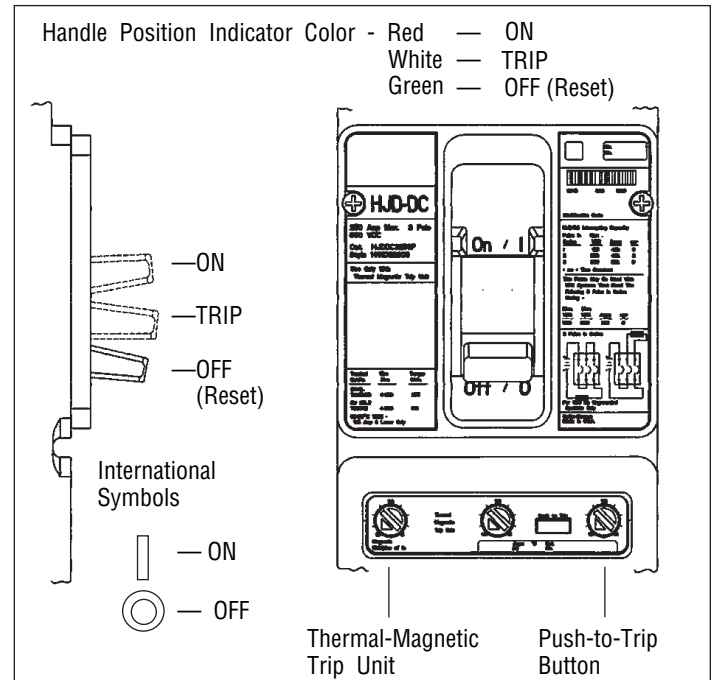

Figure 11. Circuit Breaker Manual Controls.

Circuit Breaker Reset

After an automatic or accessory initiated trip, or a manual PUSH-TO-TRIP operation, the circuit breaker is reset by moving the circuit breaker handle to the extreme OFF position.

NOTICE

IN THE EVENT OF A THERMAL TRIP IN A THERMAL MAGNETIC TYPE TRIP UNIT, THE CIRCUIT BREAKER CANNOT BE RESET UNTIL THE THERMAL ELEMENT IN THE TRIP UNIT COOLS. NO CIRCUIT BREAKER SHOULD BE RECLOSED UNTIL THE CAUSE OF TRIP IS KNOWN AND THE SITUATION RECTIFIED.

PUSH-TO-TRIP Button

The PUSH-TO-TRIP button checks the circuit breaker tripping function and is used to periodically exercise the operating mechanism in thermal-magnetic trip units. The button is designed to be operated by a small screwdriver.

Thermal-Magnetic Trip Unit Adjustment

The magnetic element of each pole of the trip unit can be adjusted by rotating the adjustment buttons on the front face of the trip unit with a small screwdriver. The buttons have several settings, as indicated on the nameplate, with values in multiples of the trip unit ampere rating (I_n), (Fig. 12). To adjust the setting, rotate each button clockwise until arrow on button points to desired setting.

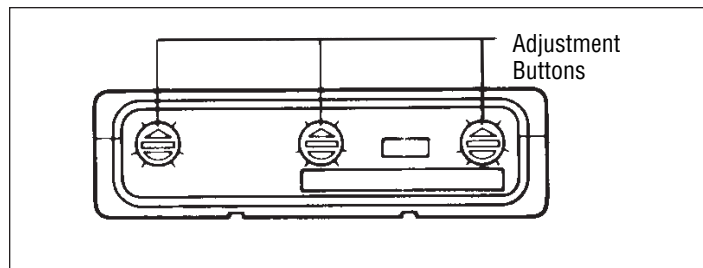

Figure 12. Trip Unit Magnetic Trip Adjustment Buttons.

4. Inspection and Field Testing

Series C molded case circuit breakers are designed to provide years of almost maintenance-free operation. The following procedure describes how to inspect and test a circuit breaker in service.

Inspection

Circuit breakers in service should be inspected periodically. The inspection should include the following checks (4-1 through 4-7):

⚠ WARNING

BEFORE INSPECTING THE CIRCUIT BREAKER IN AN ELECTRICAL SYSTEM, MAKE SURE THE CIRCUIT BREAKER IS SWITCHED TO THE OFF POSITION AND THAT THERE IS NO VOLTAGE PRESENT WHERE WORK IS TO BE PERFORMED. SPECIAL ATTENTION SHOULD BE PAID TO REVERSE FEED APPLICATIONS TO ENSURE VOLTAGE IS PRESENT. THE VOLTAGES IN ENERGIZED EQUIPMENT CAN CAUSE DEATH OR SEVERE PERSONAL INJURY.

⚠ CAUTION

MAKE SURE THAT CLEANING AGENTS OR SOLVENTS USED TO CLEAN THE CIRCUIT BREAKER ARE SUITABLE FOR THE JOB. SOME COMMERCIAL CLEANING AGENTS WILL DAMAGE THE NAME PLATES OR MOLDED PARTS.

- 4-1. Remove dust, dirt, soot, grease, or moisture from the surface of the circuit breaker using a lint-free dry cloth, brush, or vacuum cleaner. Do not blow debris into circuit breaker. If contamination is found, look for the source and eliminate the problem.
- 4-2. Switch circuit breaker to ON and OFF several times to be sure that the mechanical linkages are free and do not bind. If mechanical linkages are not free, replace circuit breaker.
- 4-3. With the circuit breaker in the ON position, press the PUSH TO-TRIP button to mechanically trip the circuit breaker. Trip, reset, and switch circuit breaker ON several times. If mechanism does not reset each time the circuit breaker is tripped, replace the circuit breaker.
- 4-4. Check base, cover, and operating handle for cracks, chipping, and discoloration. Circuit breakers should be replaced if cracks or severe discoloration is found.
- 4-5. Check terminals and connectors for looseness or signs of overheating. Overheating will show as discoloration, melting, or blistering of conductor insulation, or as pitting or melting of conductor surfaces due to arcing. If there is no evidence of overheating or looseness, do not disturb or tighten the connections. If there is evidence of overheating, terminations should be cleaned or replaced. Before reenergizing the circuit breaker, all terminations and cable should be refurbished to the condition when originally installed.
- 4-6. Check circuit breaker mounting hardware, tighten if necessary.
- 4-7. Check area where circuit breaker is installed for any safety hazards, including personal safety and fire hazards. Exposure to certain types of chemicals can cause deterioration of electrical connections.

Field Testing

Any field testing should be done in accordance with applicable NEMA Standards.

Notes:

The instructions for installation, testing, maintenance, or repair herein are provided for the use of the product in general commercial applications and may not be appropriate for use in nuclear applications. Additional instructions may be available upon specific request to replace, amend, or supplement these instructions to qualify them for use with the product in safety-related applications in a nuclear facility.

The information, recommendations, descriptions, and safety notations in this document are based on Eaton's experience and judgment with respect to Retrofitting of Power Breakers. This instructional literature is published solely for information purposes and should not be considered all-inclusive. If further information is required, you should consult an authorized Eaton sales representative.

The sale of the product shown in this literature is subject to the terms and conditions outlined in appropriate Eaton selling policies or other contractual agreement between the parties. This literature is not intended to and does not enlarge or add to any such contract. The sole source governing the rights and remedies of any purchaser of this equipment is the contract between the purchaser and Eaton.

NO WARRANTIES, EXPRESSED OR IMPLIED, INCLUDING WARRANTIES OF FITNESS FOR A PARTICULAR PURPOSE OR MERCHANTABILITY, OR WARRANTIES ARISING FROM COURSE OF DEALING OR USAGE OF TRADE, ARE MADE REGARDING THE INFORMATION, RECOMMENDATIONS, AND DESCRIPTIONS CONTAINED HEREIN.

In no event will Eaton be responsible to the purchaser or user in contract, in tort (including negligence), strict liability or otherwise for any special, indirect, incidental or consequential damage or loss whatsoever, including but not limited to damage or loss of use of equipment, plant or power system, cost of capital, loss of power, additional expenses in the use of existing power facilities, or claims against the purchaser or user by its customers resulting from the use of the information, recommendations and description contained herein.

Eaton Corporation
Electrical Group
1000 Cherrington Parkway
Moon Township, PA 15108
United States
877-ETN-CARE (877-386-2273)
Eaton.com

© 2011 Eaton Corporation
All Rights Reserved
Printed in USA
Publication No. IL 29C701D / TBG000545
Part No. 6631C44H05
January 2011

