

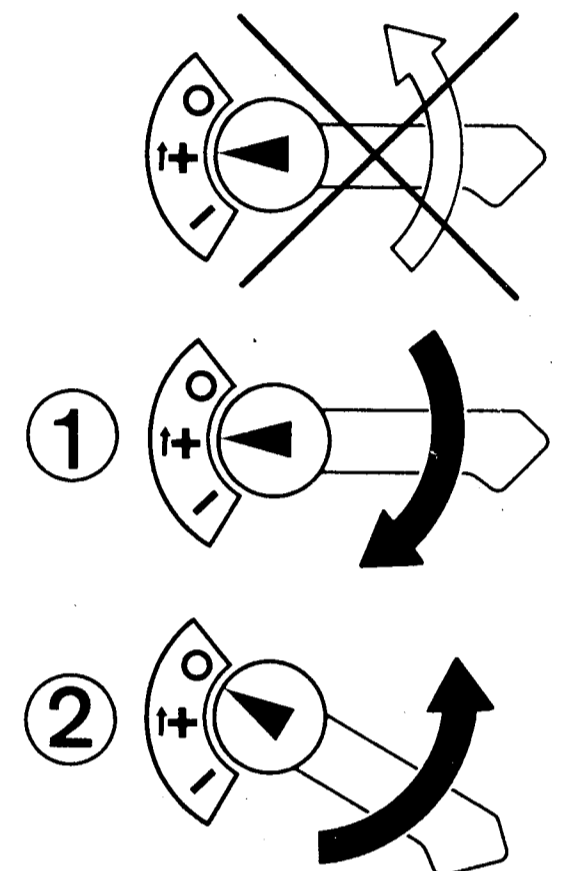

N(ZM) 11(4)-...
 NZM(S)(H) 11(4)-.../ZM 11(4)-...
 NZM 11(4)-.../ZM 11(4)V-...
 NZMH 11-.../ZMH 11H-...

4/91 AWA 123-488

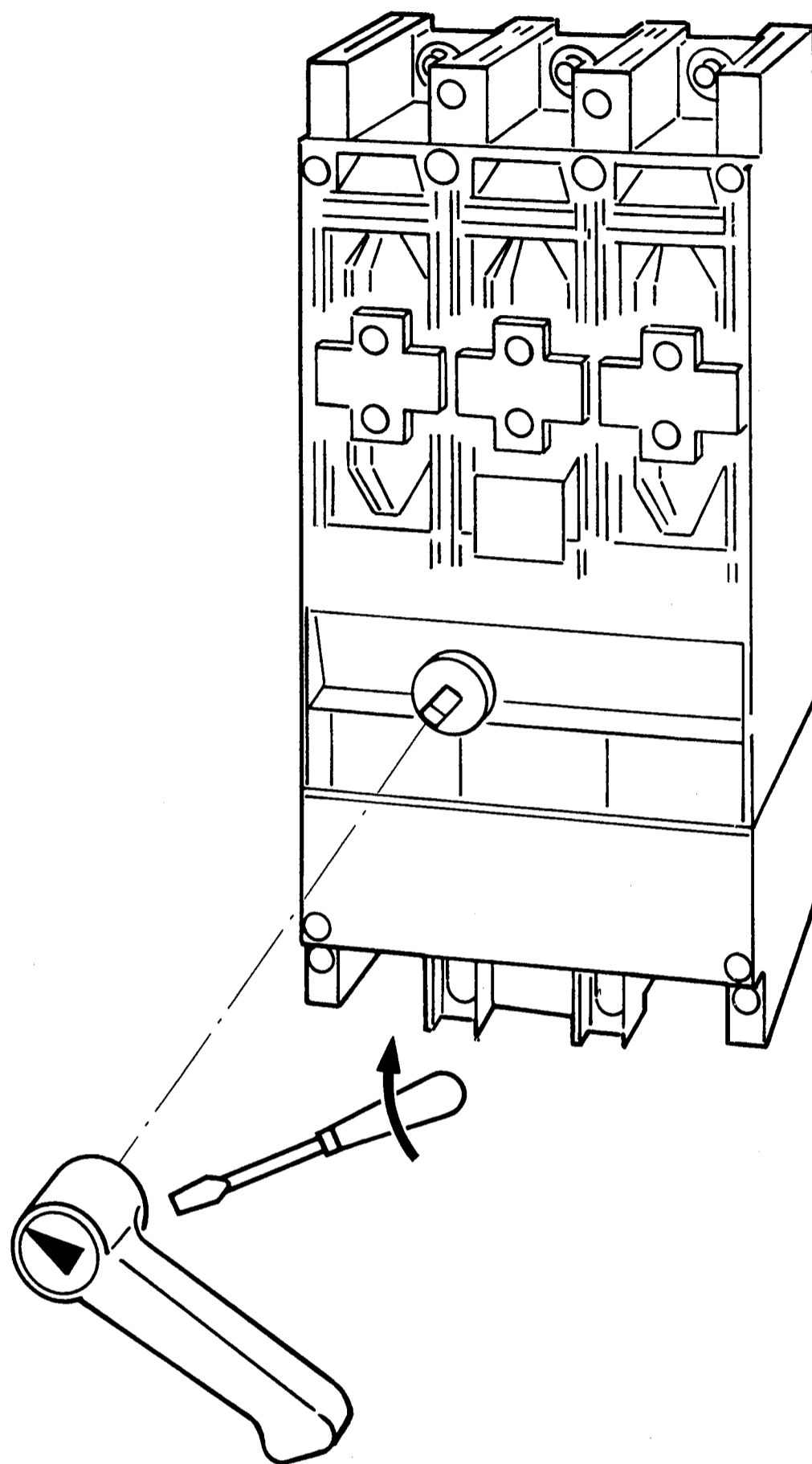

Bohrbild
Drilling template
Gabarit de perçage

⚠ NZM + CI max. 5 mm

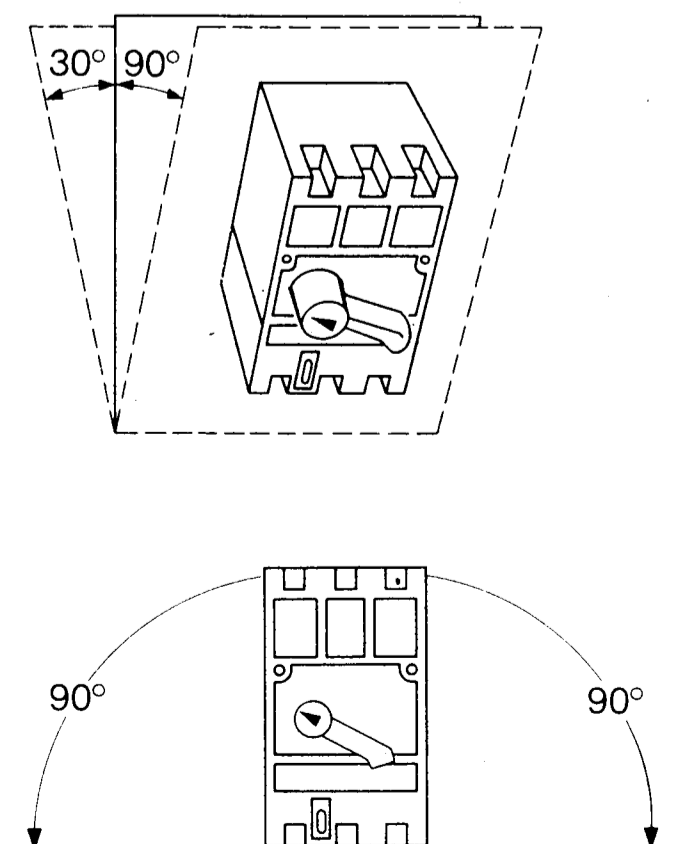
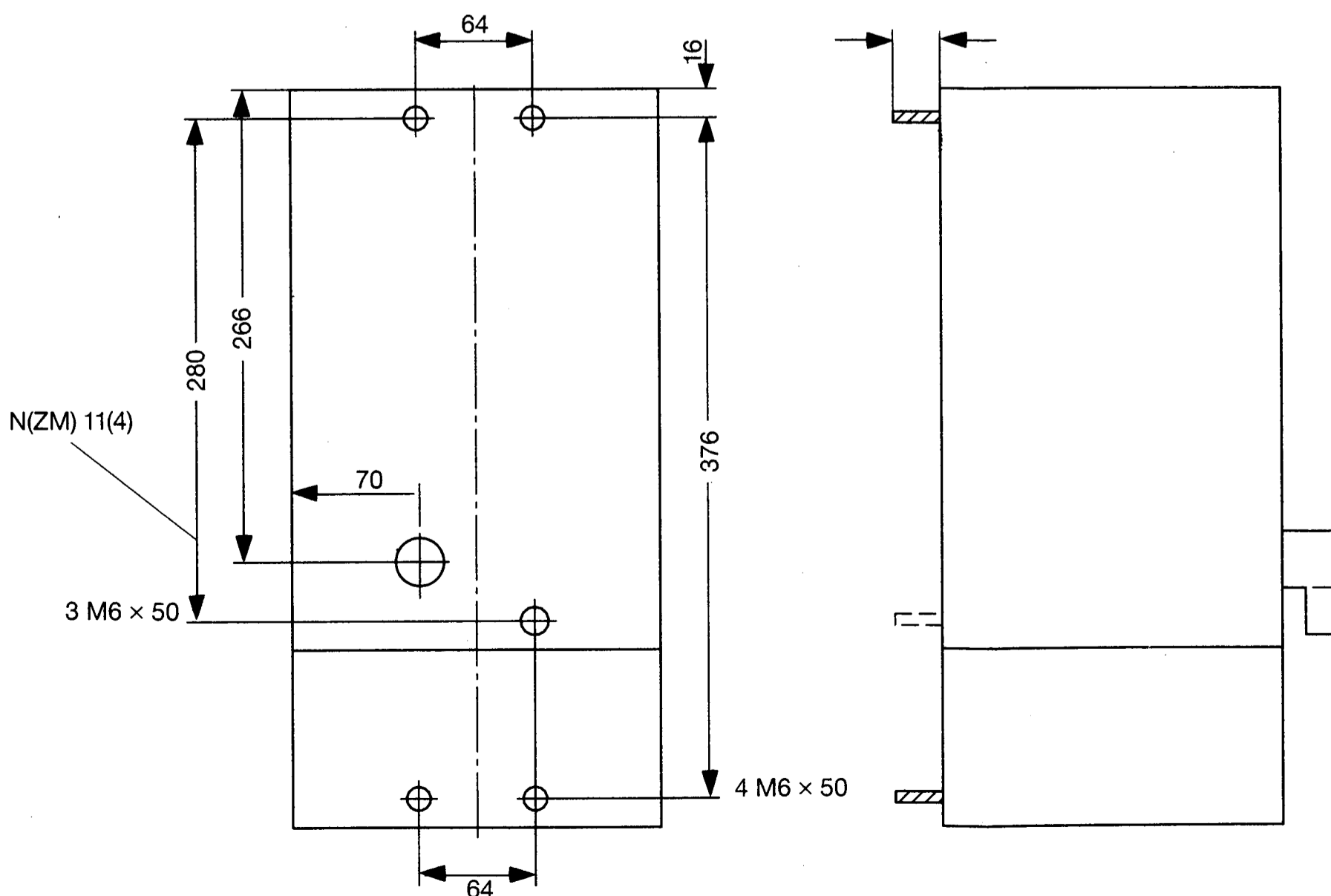

Lieferform
Type
Forme de la livraison

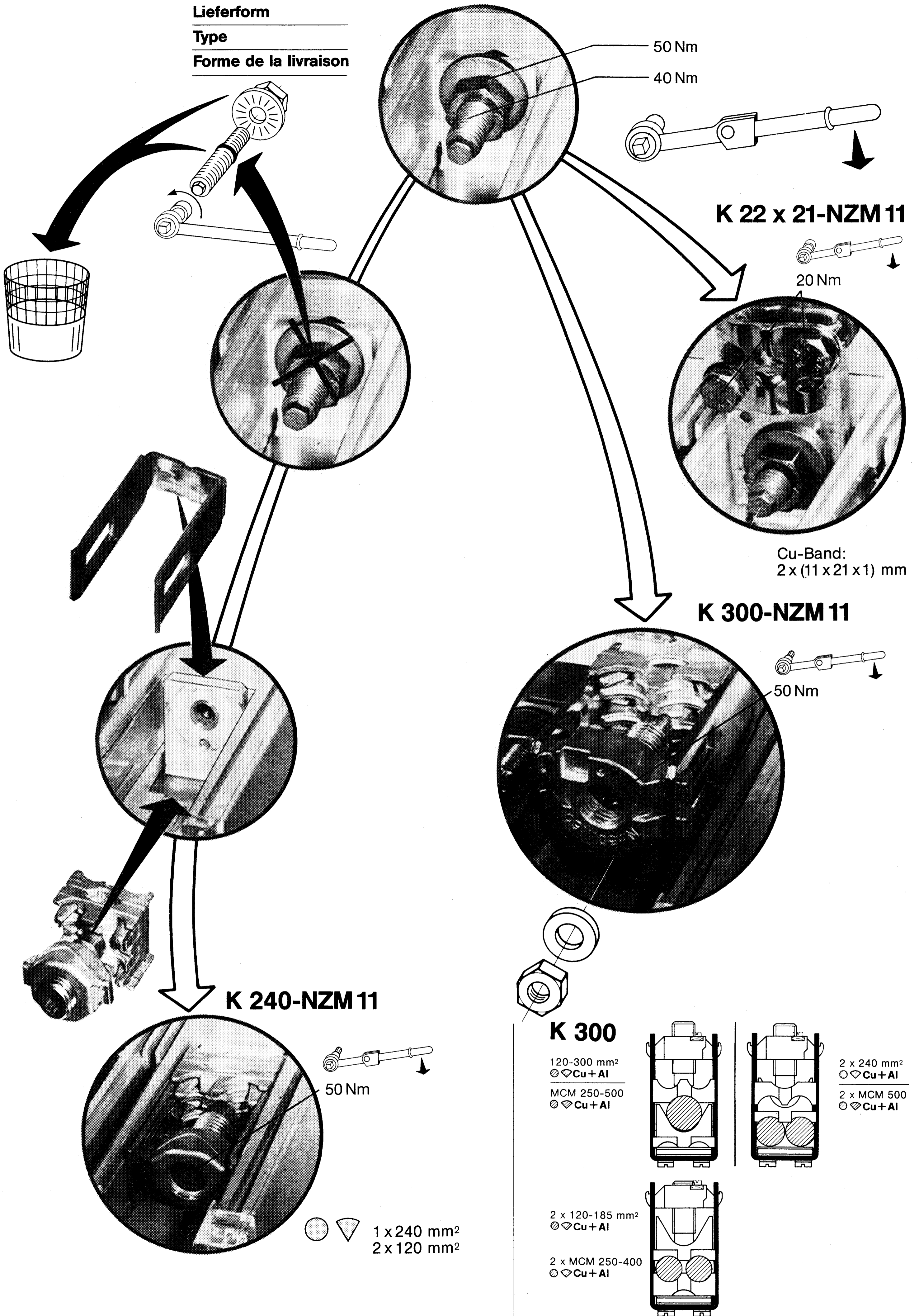

50 Nm
 40 Nm

K 22 x 21-NZM 11

20 Nm

Cu-Band:
 2 x (11 x 21 x 1) mm

K 300-NZM 11

50 Nm

K 240-NZM 11

50 Nm

1 x 240 mm²
 2 x 120 mm²

K 300

120-300 mm²
 Cu + Al
 MCM 250-500
 Cu + Al

2 x 240 mm²
 Cu + Al
 2 x MCM 500
 Cu + Al

2 x 120-185 mm²
 Cu + Al

2 x MCM 250-400
 Cu + Al

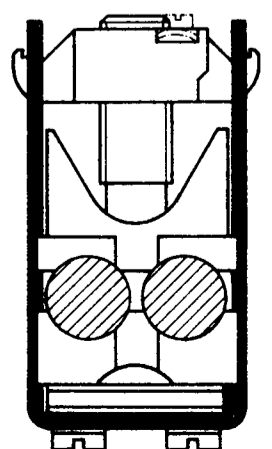
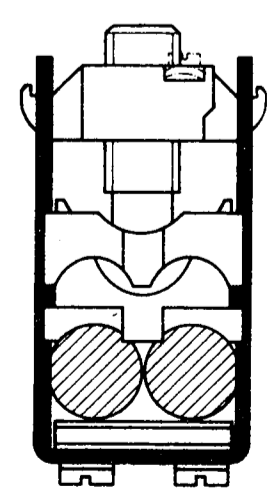
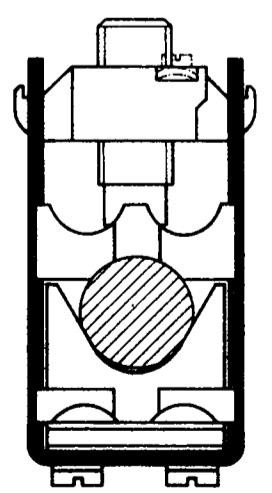

NZM 11(4)-.../ZM 11(4)-...
 NZM H 11(4)-.../ZM 11(4)-...

NZM 11(4)-.../ZM 11(4)V-...
 NZMH 11-.../ZMH 11H-...

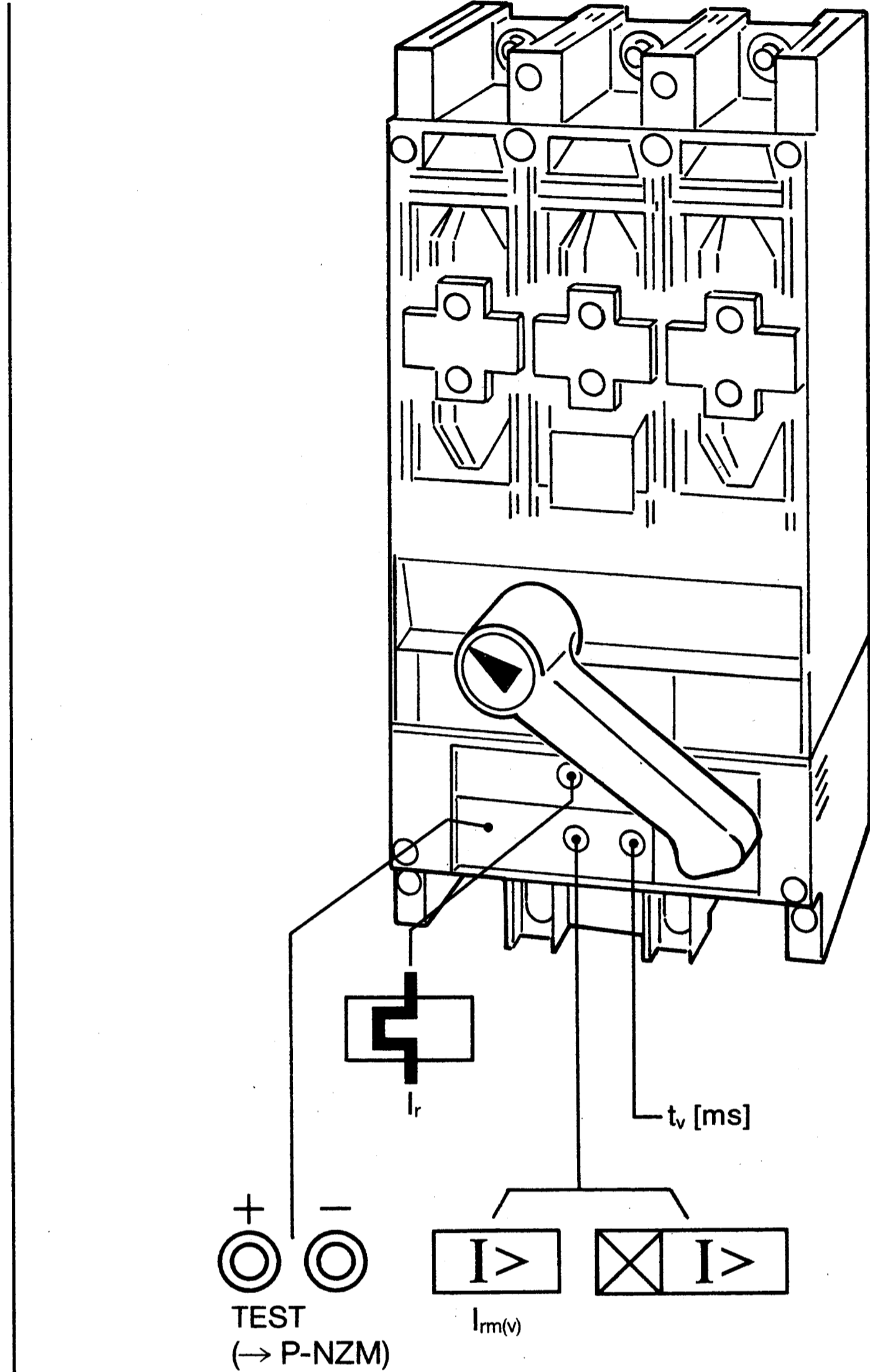
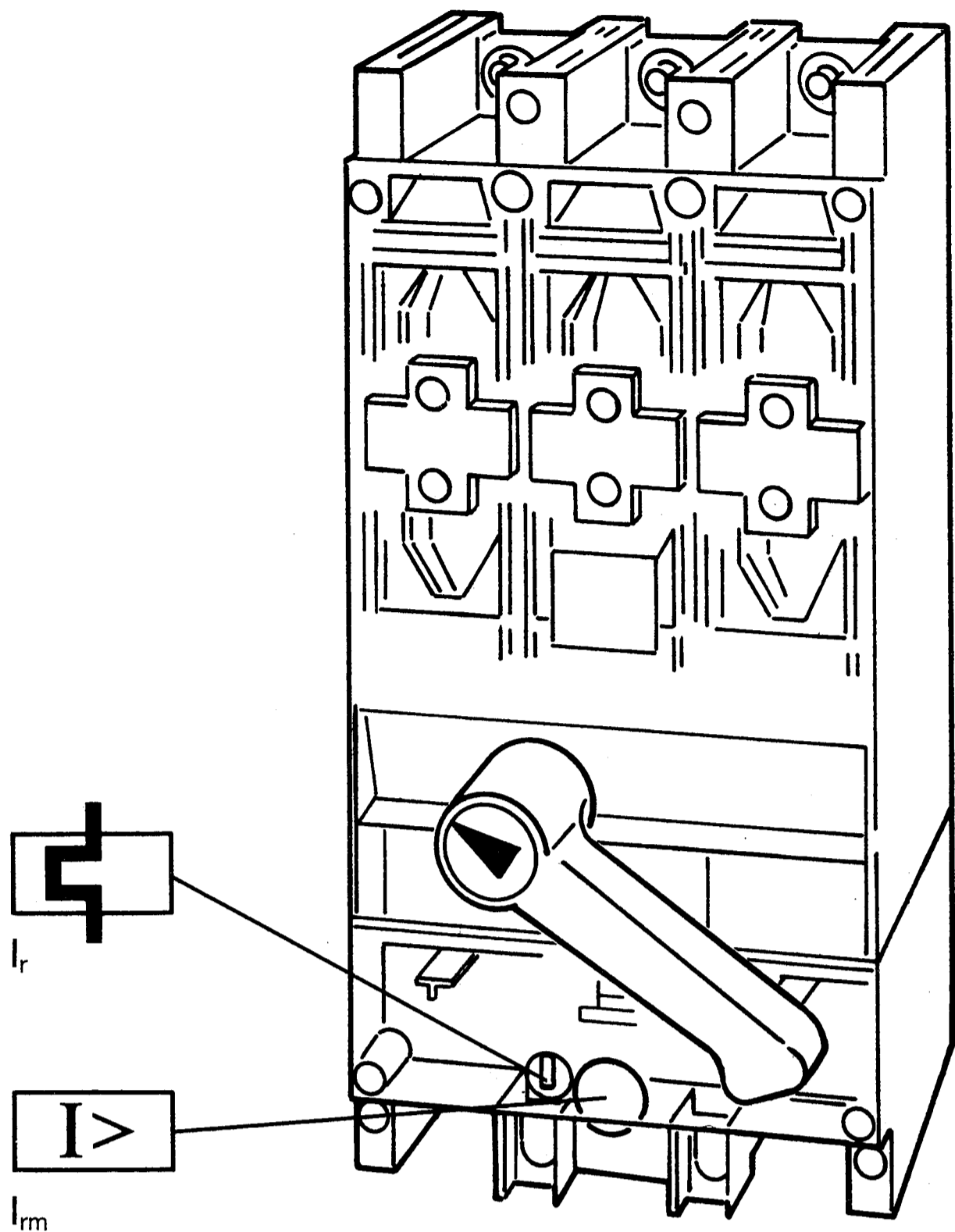

NZM H 11-.../ZM H 11 H-...

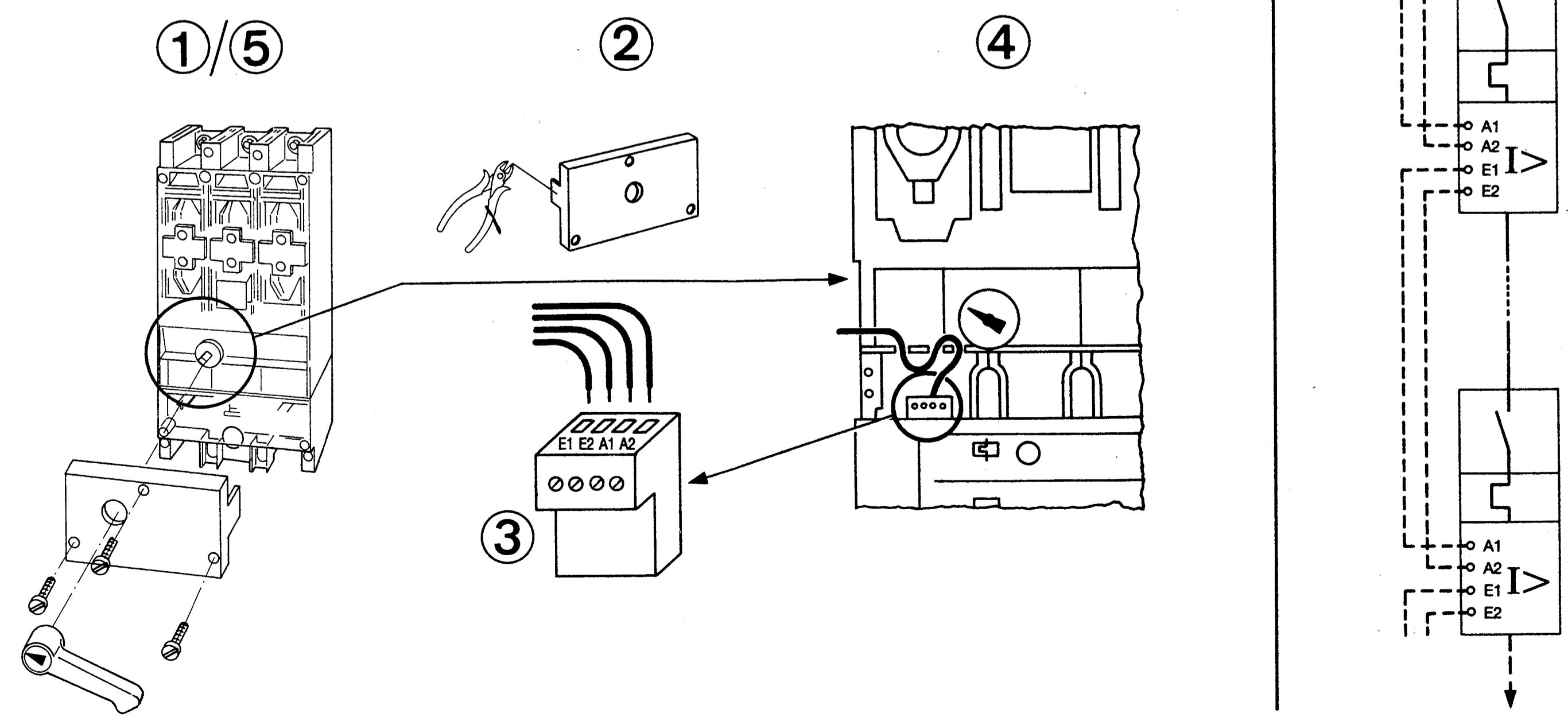

Auswechseln ZM...

Exchanging ZM...

Remplacement ZM...

