

Montageanweisung
Installation Instructions
Notice d'installation
Istruzioni per il montaggio

Instrucciones de montaje
Инструкция по монтажу
安裝說明

NHI...-NZM 144 NRHI...-NZM 144

Einbau in 4polige Schalter ohne Ausfahrinheit AF
Mounting in 4-pole switches without withdrawable unit AF
Montage dans disjoncteurs tétrapolaires sans unité de débrogage AF
Montaggio sugli interruttori 4polari senza unità estraibile AF
Montaje en interruptores 4polares sin unidad seccionable AF
Встраивание в 4-полюсный выключатель без единицы выдвижения AF
安裝在无抽取单元 AF 的 4 极开关内

NHI 002, NRHI 002

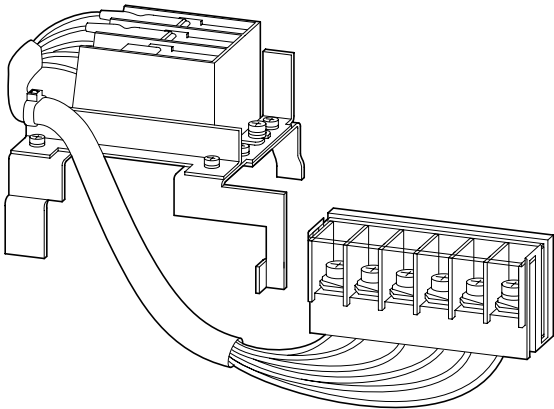

NHI 003, NRHI 003

Nachrüstung bei Geräten mit LUE-NZM 14 nicht möglich
Retrofitting devices with LUE-NZM 14 not possible
Équipement ultérieur non possible sur appareils avec LUE-NZM 14
Non è possibile il successivo montaggio di accessori per interruttori con LUE-NZM 14
No es posible en aparatos con LUE-NZM 14
Дополнительное оснащение приборов устройствами LUE NZM 14 невозможно
对带有 LUE-NZM 14 的装置不能进行加装

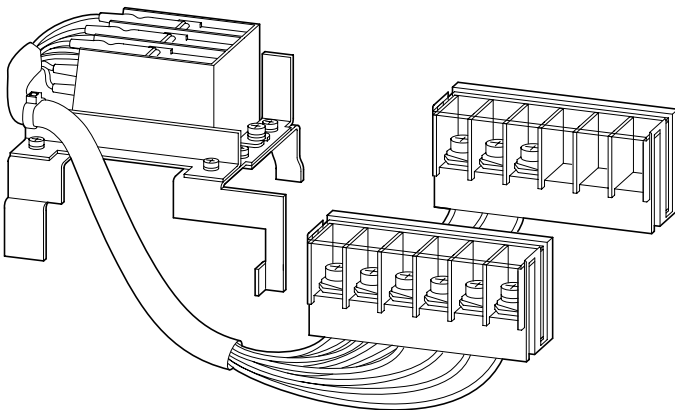

Lebensgefahr durch elektrischen Strom!
Nur Elektrofachkräfte und elektrotechnisch unterwiesene Personen dürfen die im folgenden beschriebenen Arbeiten ausführen.

Electric current! Danger to life!

Only skilled or instructed persons may carry out the following operations.

Tension électrique dangereuse !

Seuls les personnes qualifiées et averties doivent exécuter les travaux ci-après.

Pericolo di morte causa corrente elettrica!

Solo persone istruite e avvertite possono eseguire le operazioni di seguito riportate.

¡Corriente eléctrica! ¡Peligro de muerte!

El trabajo a continuación descrito debe ser realizado por personas cualificadas y advertidas.

Электрический ток! Опасно для жизни!

Только специалисты или проинструктированные лица могут выполнять следующие операции.

触电危险!
只允许专业人员和受过专业训练的人员进行下列工作。

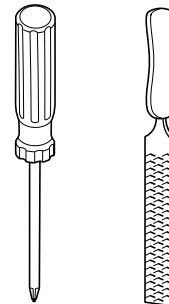

H1, H2, H3

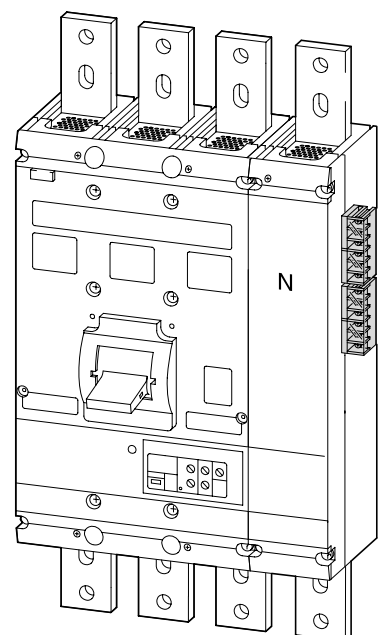



Gerät komplett spannungsfrei schalten

De-energize the device completely

Mettre l'appareil hors tension

Mettere l'apparecchio completamente fuori tensione

El aparato debe estar completamente sin tensión

Прибор полностью отключить от напряжения

使到整套设备无电压

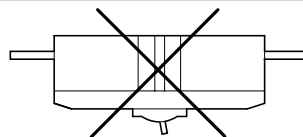
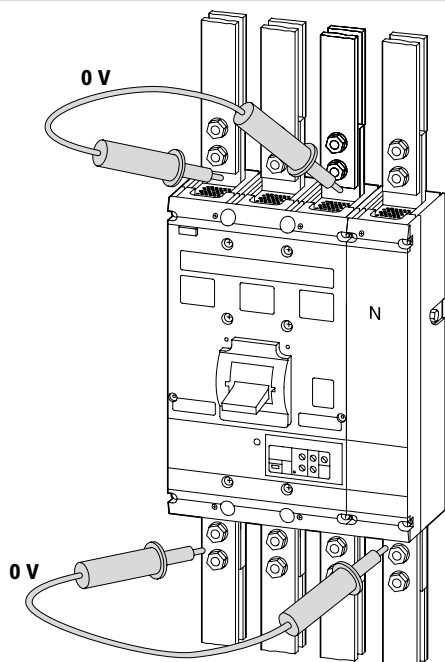

Die folgenden Arbeitsschritte dürfen nicht bei Über-Kopf-Montage durchgeführt werden.

The following working steps must not be carried out with overhead installation.

Les étapes suivantes ne doivent pas être effectuées en cas de montage au-dessus de la tête.

Le seguenti operazioni dovrebbero essere eseguite in condizioni di lavoro agevoli.

Las siguientes etapas de trabajo no pueden realizarse si el interruptor está instalado como se indica en el dibujo.

Нельзя проводить следующие рабочие шаги при монтаже над головой

在倒头安装时不能进行下列的工作

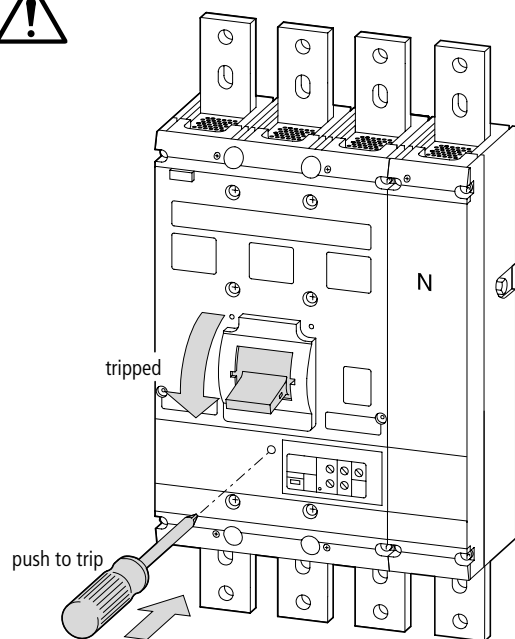

1

6 × M6 × 90



H 3

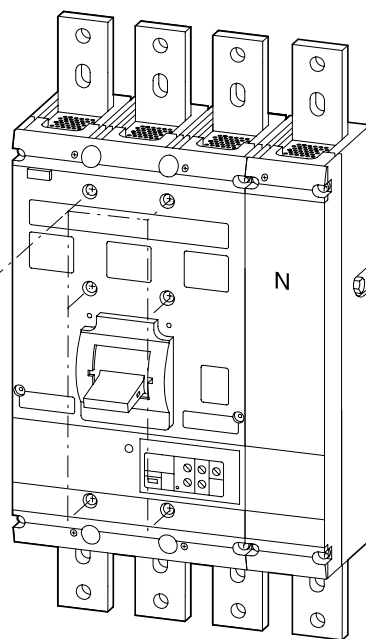

2

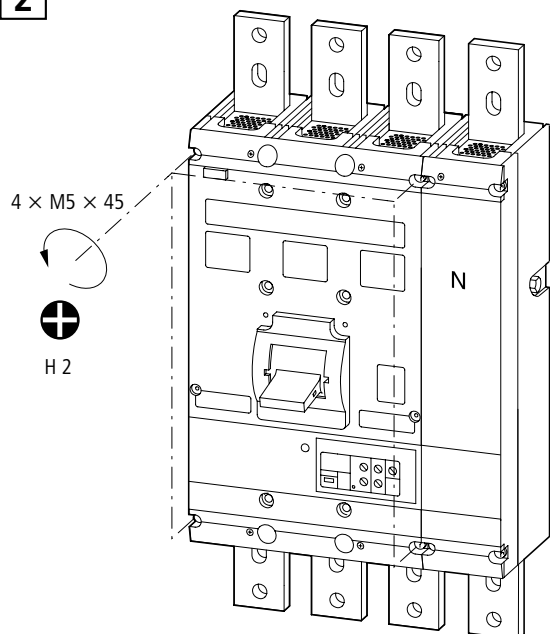

3

4 × M4 × 40

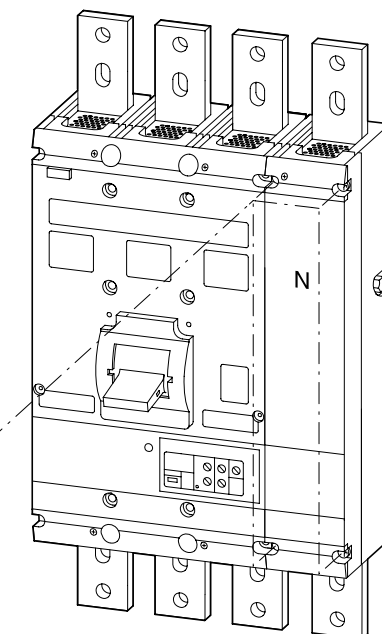

4

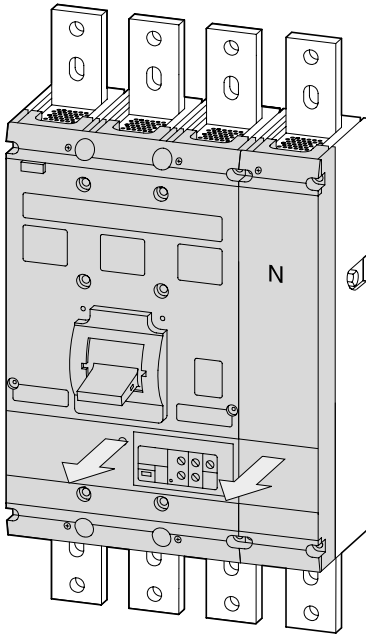

1

Falls vorhanden, N(R)HI...-NKM 144 ausbauen
 Dismantle N(R)HI...-NKM 144 if present
 Si présent, démonter l'N(R)HI...-NKM 144
 Se presente, smontare l'N(R)HI...-NKM 144
 Desmontar N(R)HI...-NKM 144 si está presente
 Если имеется, снять N(R)HI...-NKM 144
 如果存在, 将N(R)HI...-NKM 144拆出来

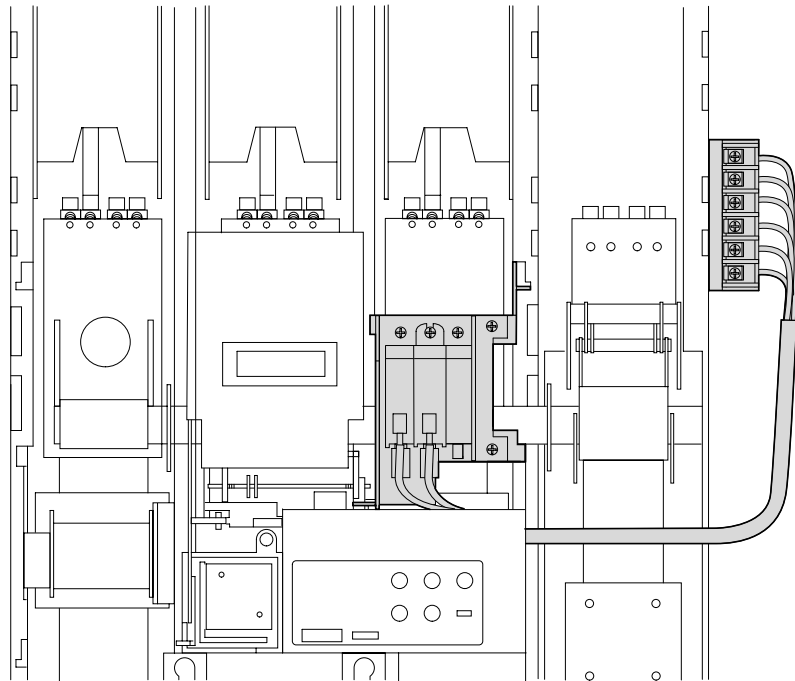

2

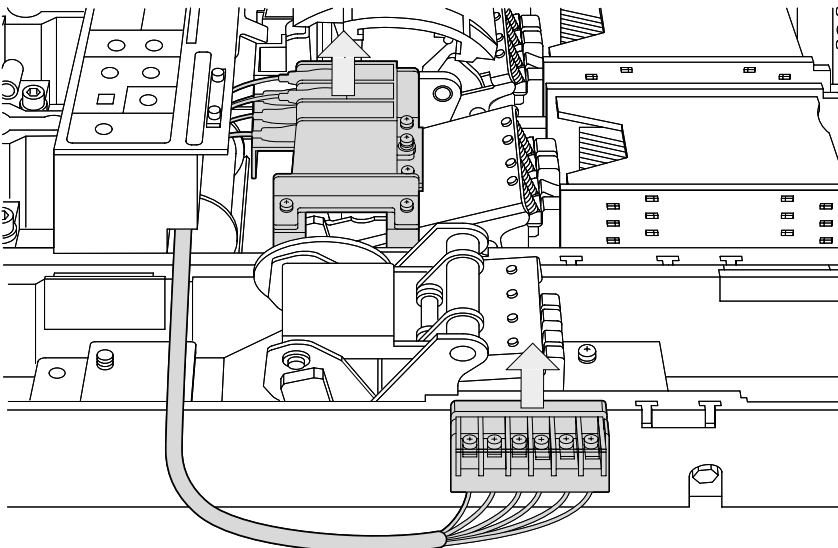

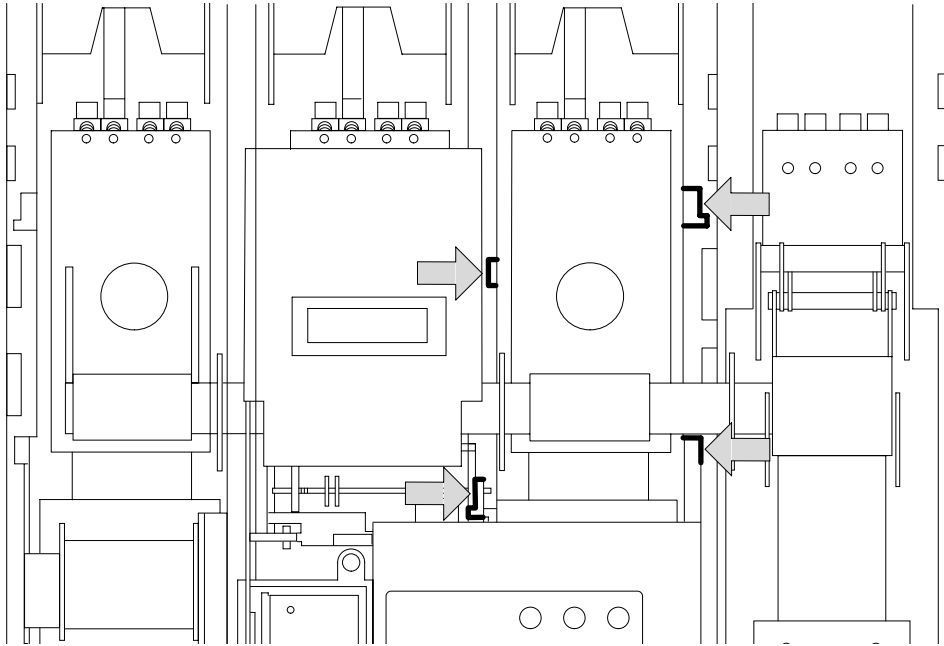

**NHI 002,
NRHI 002**

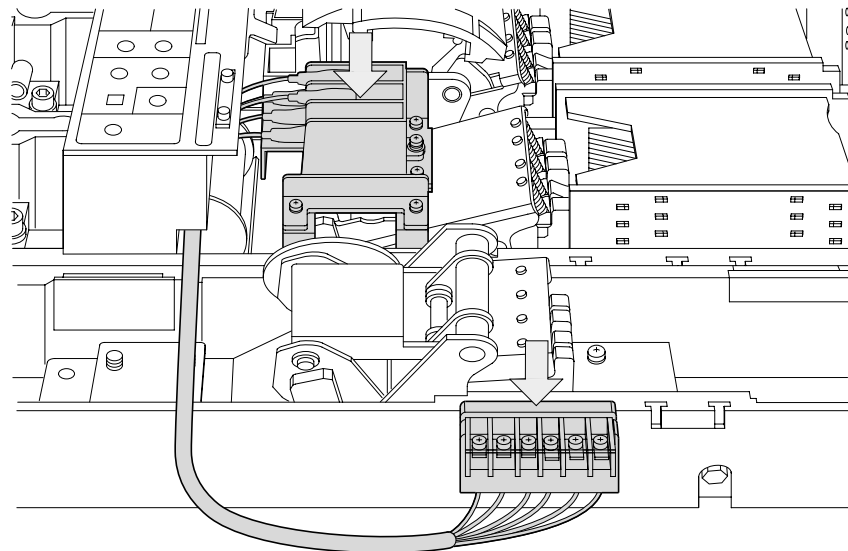

**NHI 002,
NRHI 002**

+ LUE-NZM 14

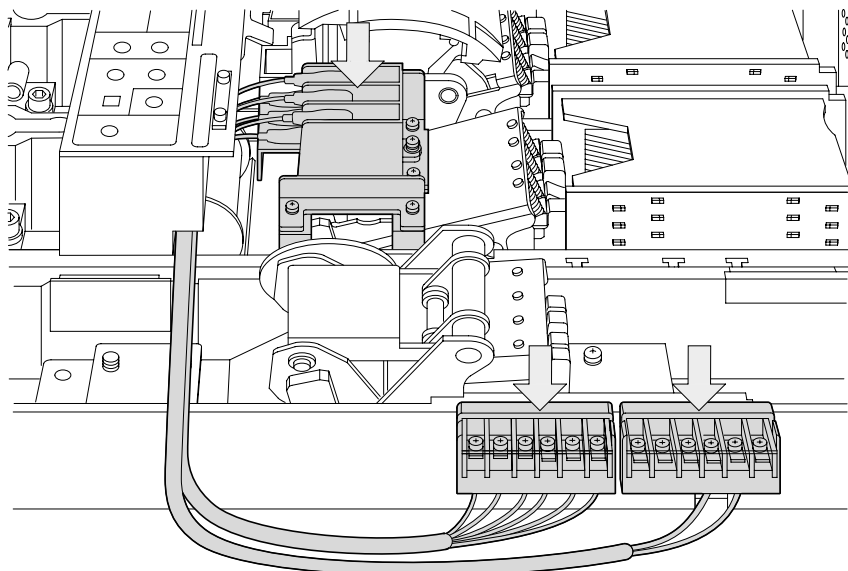

**NHI 003,
NRHI 003**

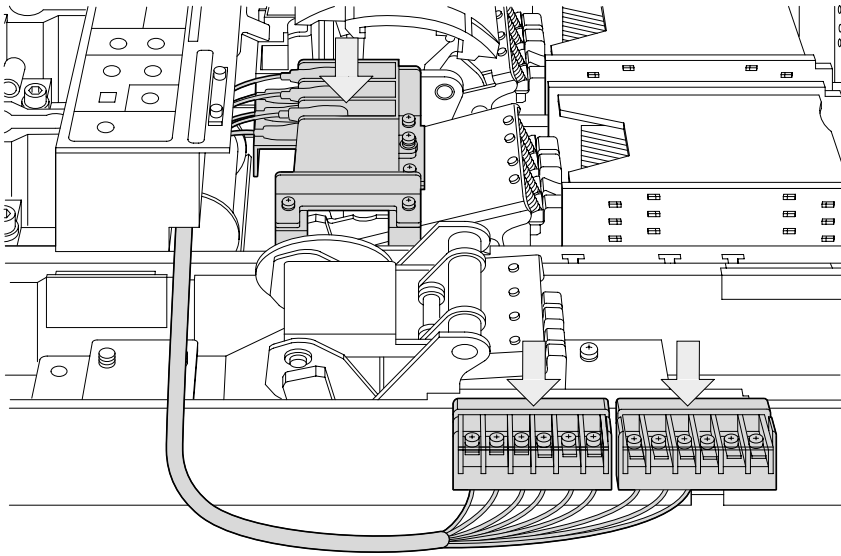

2

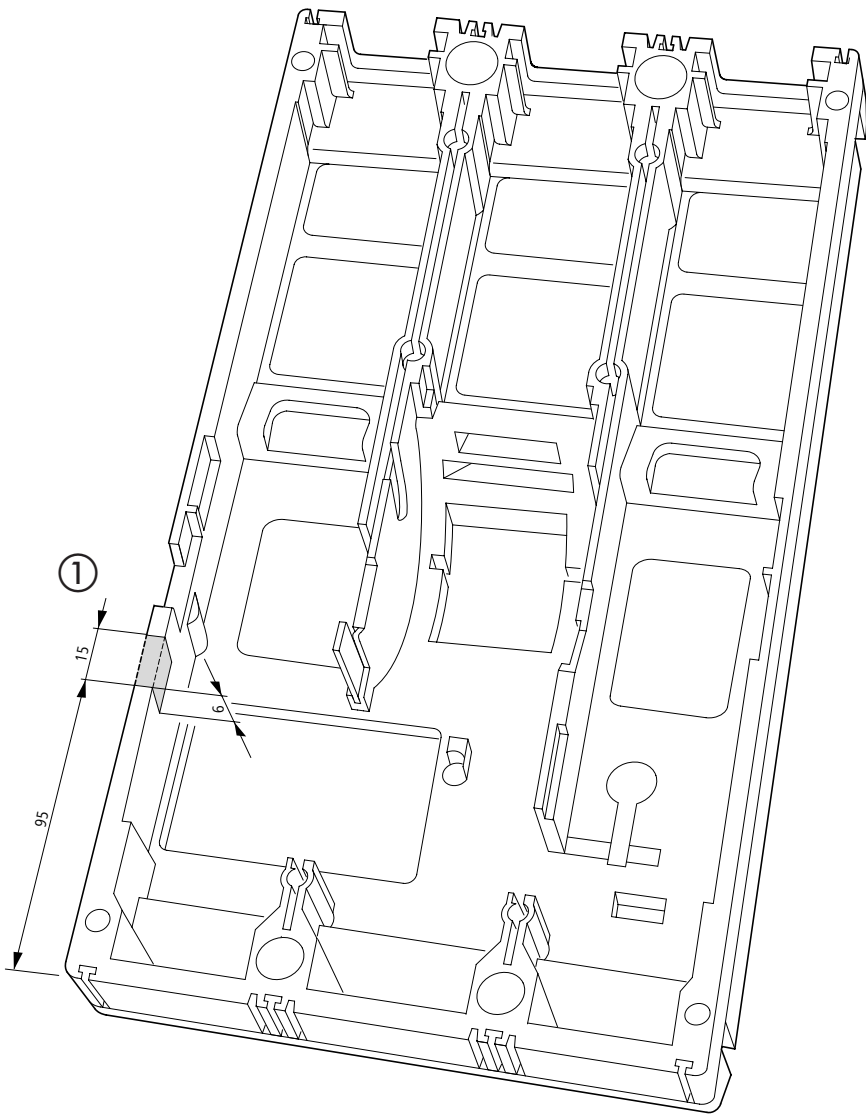

Falls nicht vorhanden
 If not present
 Si non présent
 Se non presente
 Si no está presente
 Если не имеется
 如果沒有

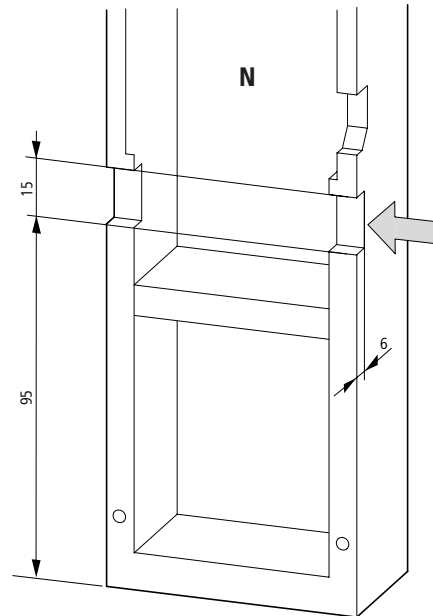
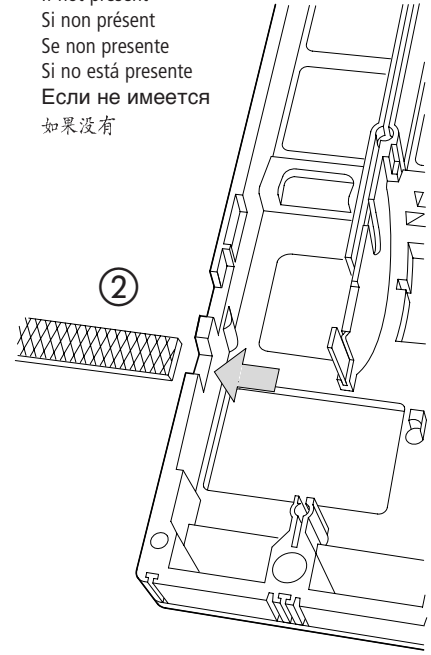

3

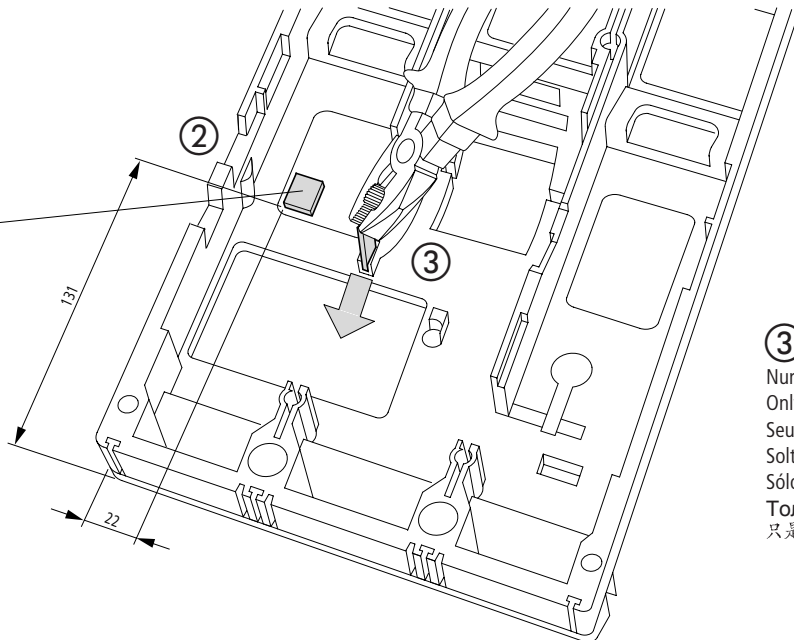
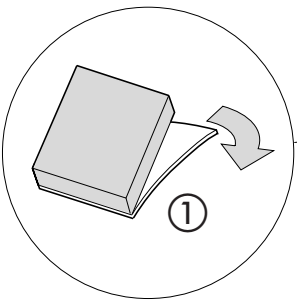

3
 Nur bei NRHI
 Only with NRHI
 Seulement pour NRHI
 Soltanto con NRHI
 Sólo con NRHI
 Только у NRHI
 只是 NRHI

4

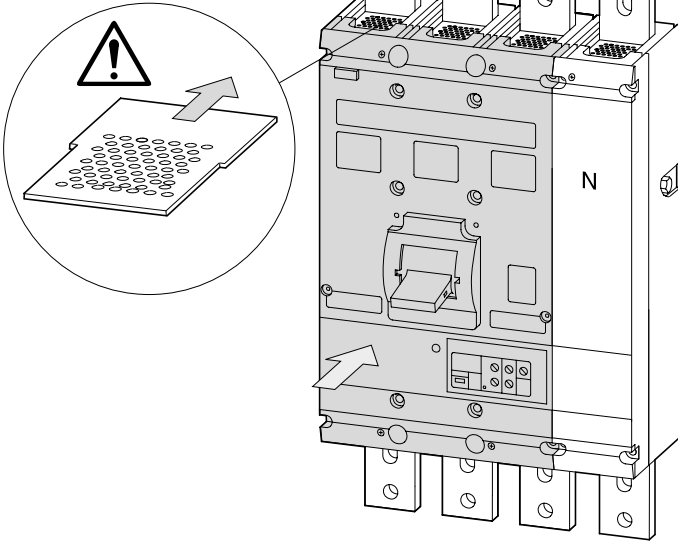

5

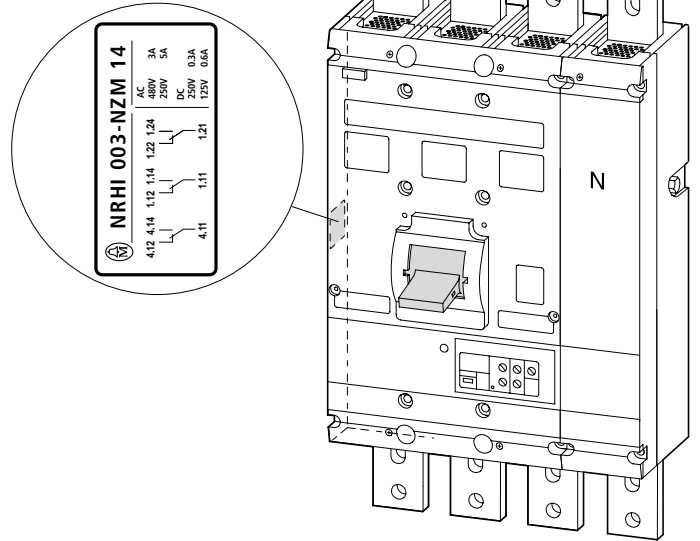

6

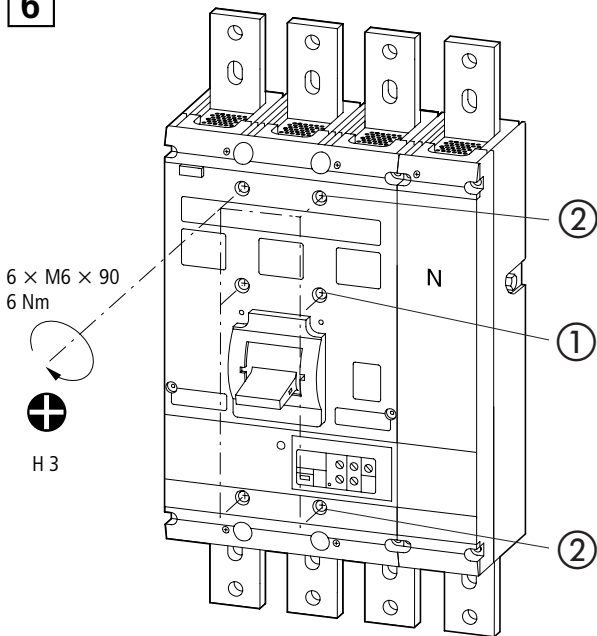

7

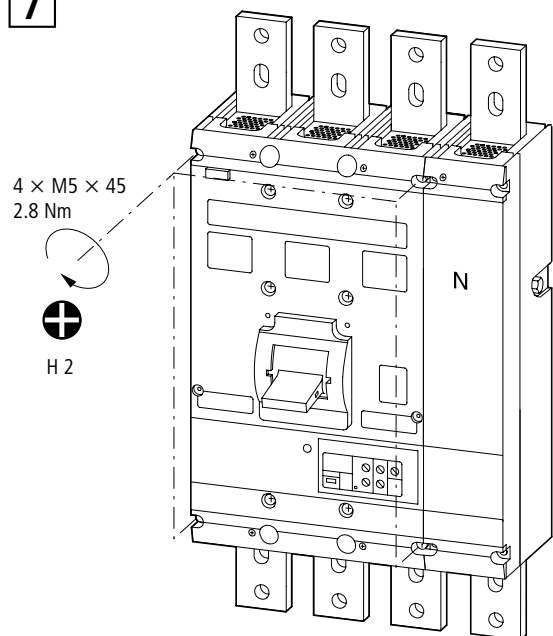

8

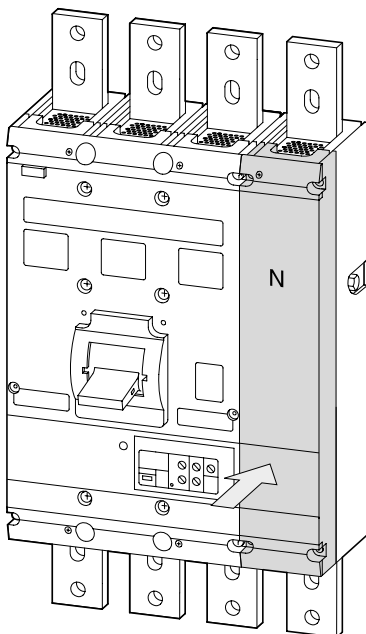

9

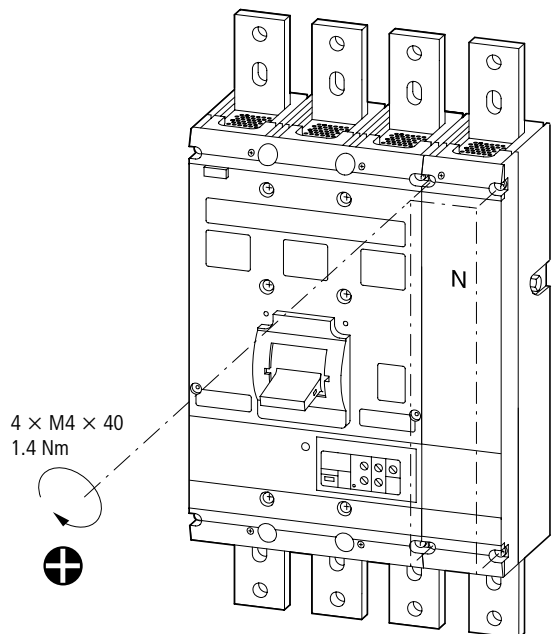

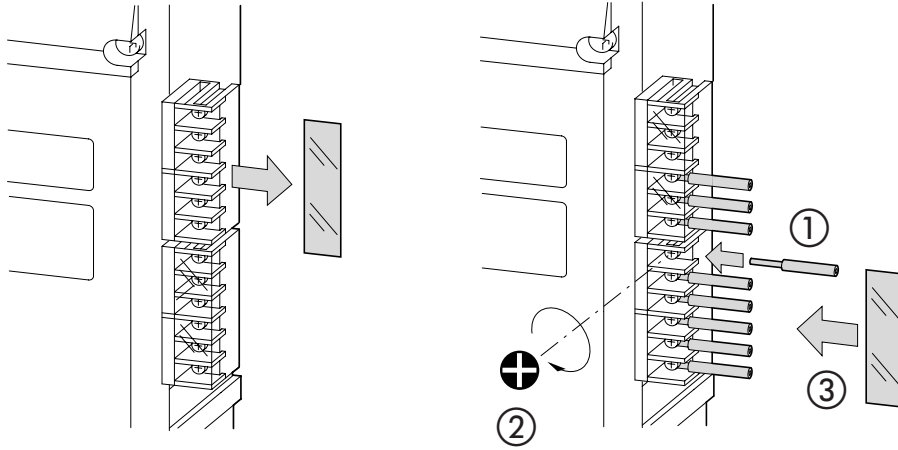

NHI 002-NZM 14

NHI 003-NZM 14

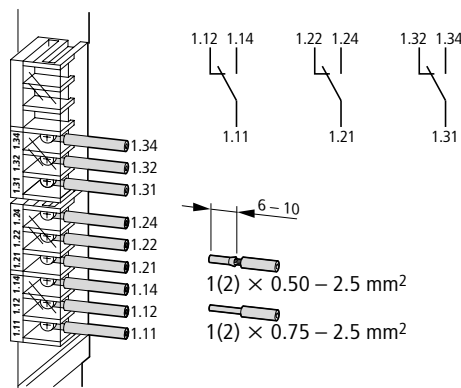
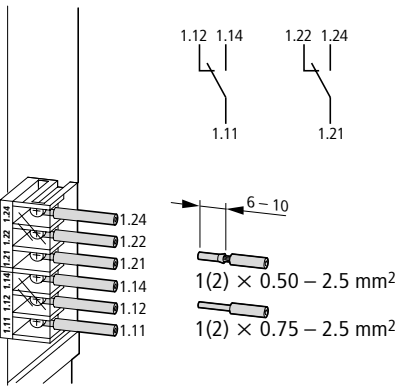

NRHI 002-NZM 14

NRHI 003-NZM 14

