

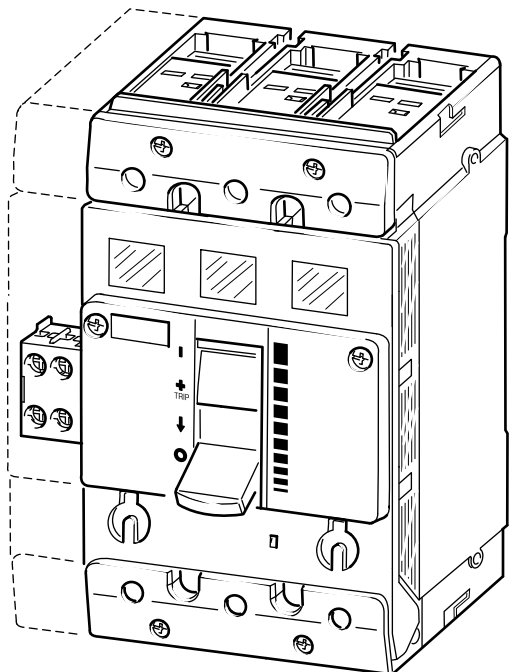

05/97 AWA 123-1340

## A-NZM 7(4) A VHI-NZM 7(4)

05/97 AWA 123-1340



### Lebensgefahr durch elektrischen Strom!

Nur Elektrofachkräfte und elektrotechnisch unterwiesene Personen dürfen die im folgenden beschriebenen Arbeiten ausführen.

### Electric current! Danger to life!

Only skilled or instructed persons may carry out the following operations.

### Tension électrique dangereuse !

Seuls les personnes qualifiées et averties doivent exécuter les travaux ci-après.

### Pericolo di morte causa corrente elettrica!

Solo persone istruite e avvertite possono eseguire le operazioni di seguito riportate.

### ¡Corriente eléctrica! ¡Peligro de muerte!

El trabajo a continuación descrito debe ser realizado por personas cualificadas y advertidas.

### 触电危险!

只允许专业人员和受过专业训练的人员进行下列工作。

### A-NZM 7

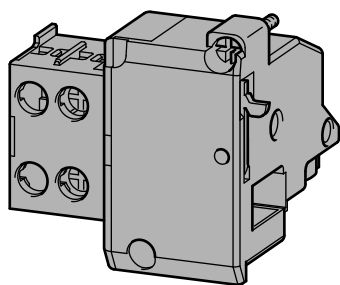

### AVHI-NZM 7

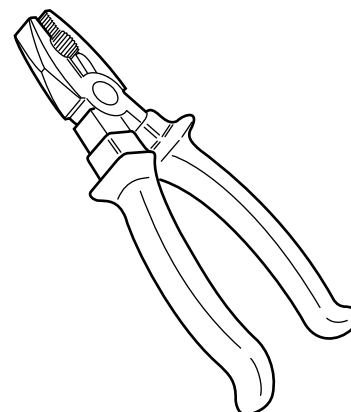
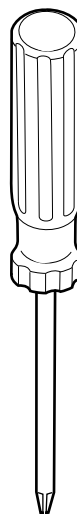
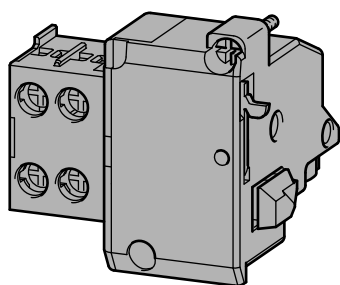

PZD 2



1



OFF

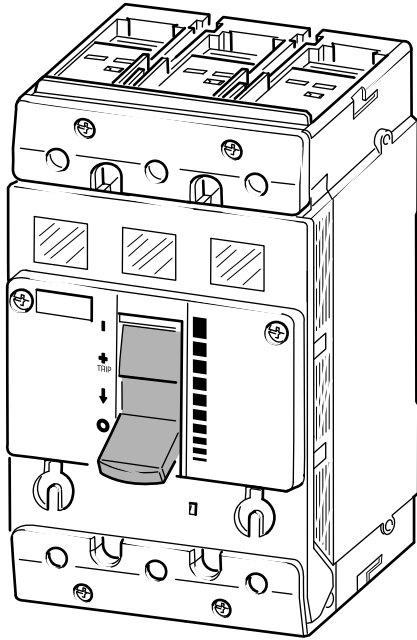

2

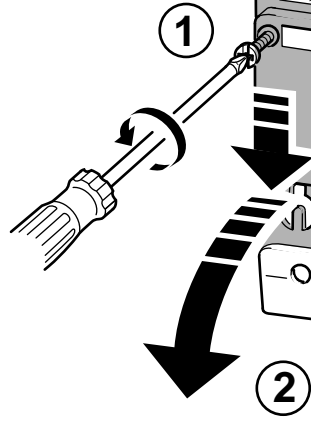

3

NZM 7

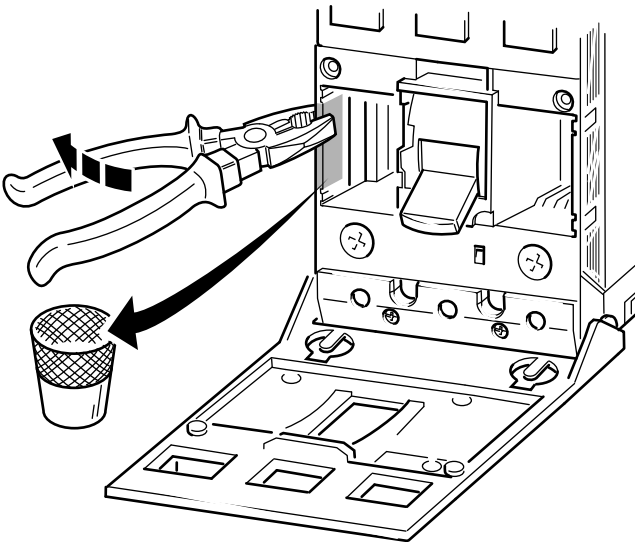

4

NZM 7

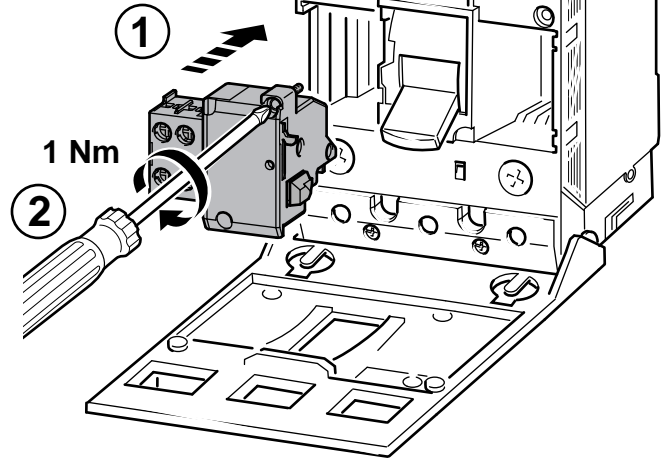

05/97 AWA 123-1340

**3** NZM 74

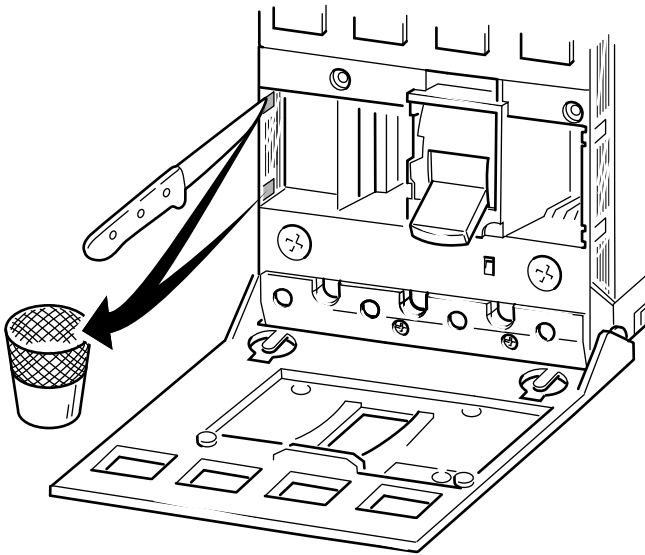

**4** NZM 74

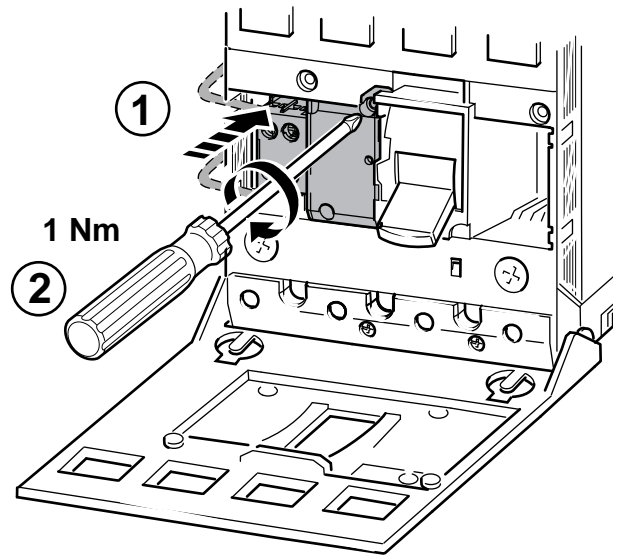

**5**

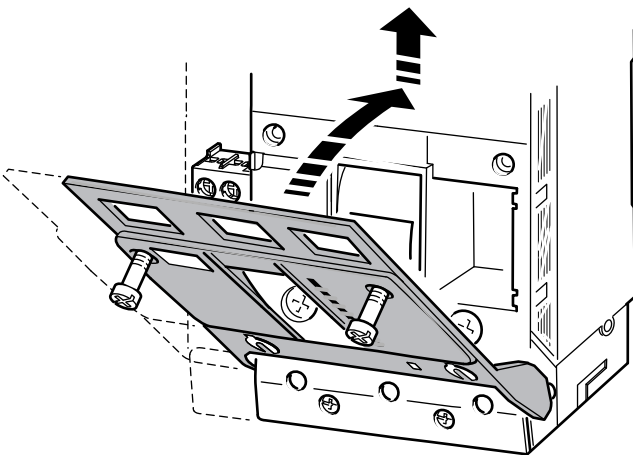

**6**

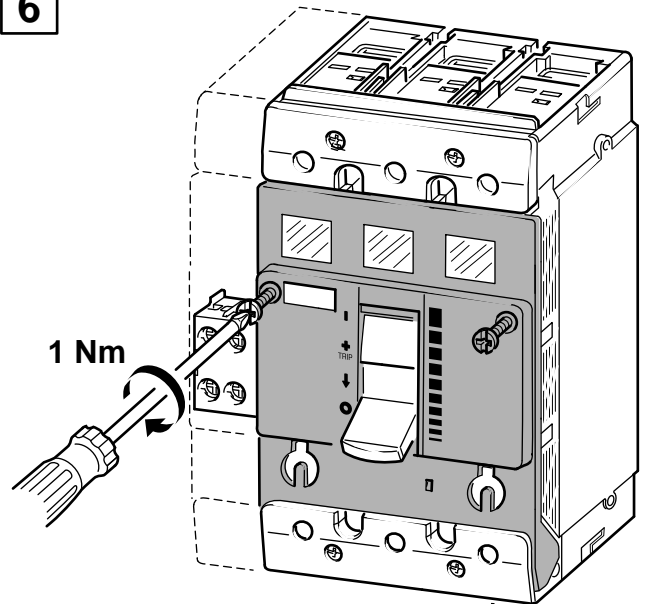



05/97 AWA 123-1340

**7**

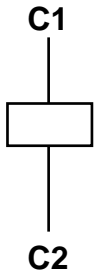
A-NZM 7



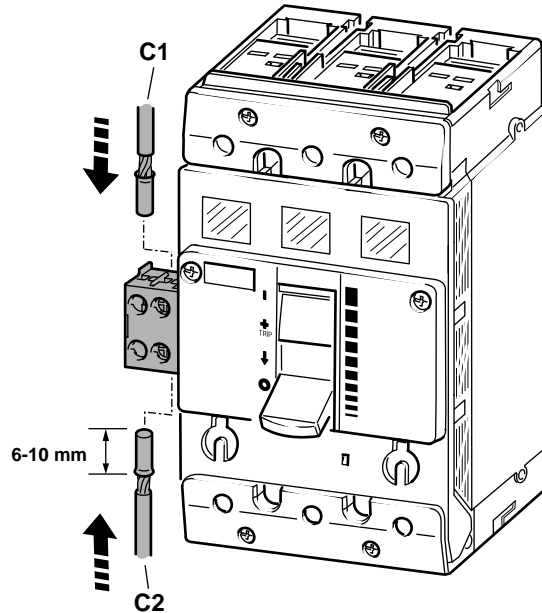

 1(2) x 0.75...2.5 mm<sup>2</sup>  
 1(2) x 0.50...2.5 mm<sup>2</sup>

**8**

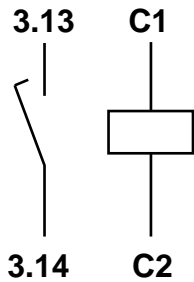
AVHI-NZM 7

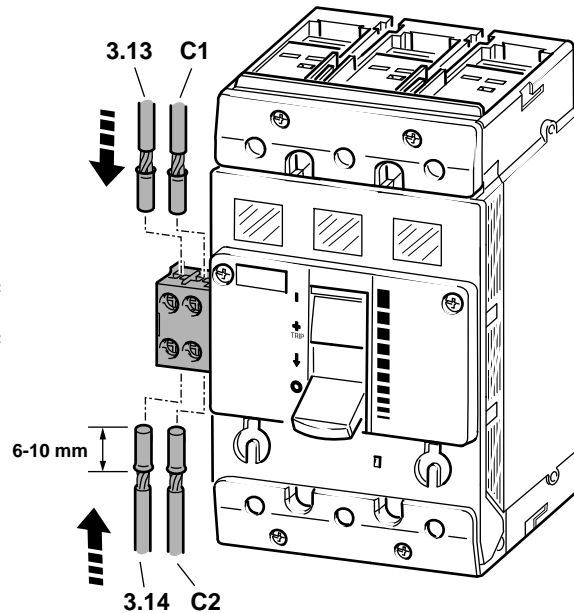
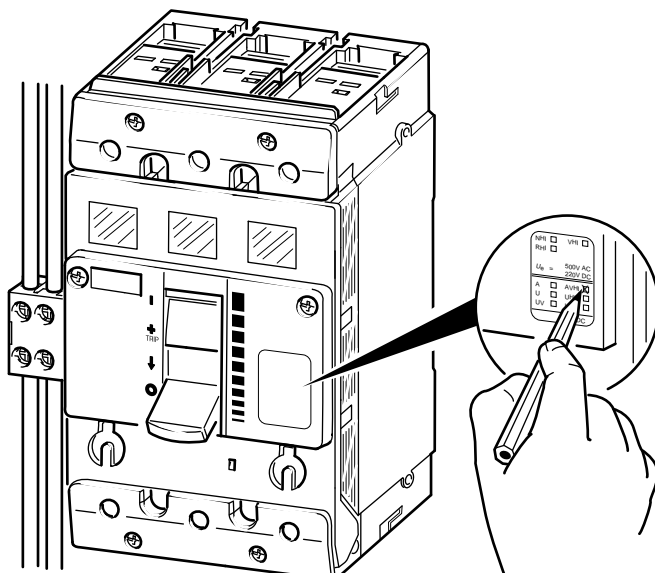

 1(2) x 0.75...2.5 mm<sup>2</sup>  
 1(2) x 0.50...2.5 mm<sup>2</sup>

**9**

- Beschriftung mit wischfestem Filzstift
- Marking with a water-proof felt pen
- Inscire la référence avec un stylo feutre indélébile
- Dicitura con perno di feltro resistente all'acqua
- Marcar con un lápiz de feltro resistente al agua