

11/10 IL01210014Z
(AWA1230-2241)

NZM4(-4)-XKV95 NZM4-XKV110 NZM4-4-XKV120

Extended Width Connector Plates for NZM4 Molded Case Circuit Breakers and Switches

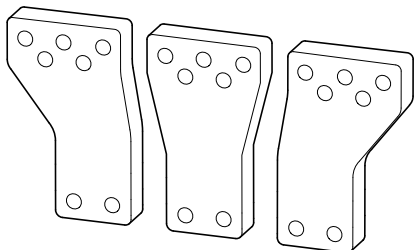

⚡ (en) Electric current! Danger to life!

Only skilled or instructed persons may carry out the following operations.

(de) Lebensgefahr durch elektrischen Strom!

Nur Elektrofachkräfte und elektrotechnisch unterwiesene Personen dürfen die im Folgenden beschriebenen Arbeiten ausführen.

(fr) Tension électrique dangereuse !

Seules les personnes qualifiées et averties doivent exécuter les travaux ci-après.

(es) ¡Corriente eléctrica! ¡Peligro de muerte!

El trabajo a continuación descrito debe ser realizado por personas cualificadas y advertidas.

(it) Tensione elettrica: Pericolo di morte!

Solo persone abilitate e qualificate possono eseguire le operazioni di seguito riportate.

(zh) 触电危险!

只允许专业人员和受过专业训练的人员进行下列工作。

(ru) Электрический ток! Опасно для жизни!

Только специалисты или проинструктированные лица могут выполнять следующие операции.

⚠ (en) Caution!

The removal or exchange of parts during mounting may become necessary. Refer to installation instructions for proper assembly and to maintain electrical clearances.

(de) Vorsicht!

Für die Durchführung der beschriebenen Arbeiten kann das Entfernen oder der Austausch von Teilen notwendig sein. Bitte alle Installations-Anweisungen beachten, um die erforderlichen Luft- und Kriechstrecken nach dem Zusammenbau zu gewährleisten.

(fr) Attention !

L'enlèvement ou l'échange de certaines pièces pendant le montage est parfois nécessaire. Consultez l'instruction d'assemblage pour assurer une installation conforme aux normes.

(es) ¡Atención!

Con el fin de llevar a cabo los trabajos descritos, puede ser necesario eliminar o cambiar alguna pieza. Le rogamos tenga en cuenta todas las instrucciones de instalación para así garantizar las líneas de fuga y efluvo necesarias tras el montaje.

(it) Attenzione!

Per l'esecuzione degli interventi descritti potrebbe essere necessaria la rimozione o sostituzione di alcuni pezzi. Attenersi alle istruzioni d'installazione per garantire dopo l'assemblaggio le vie di dispersione necessarie.

(zh) 小心!

执行所描述的操作时可能需要拆除或更换零部件。请遵守所有相关的安装说明，以确保在组装后能获得需要的空间距离或爬电距离。

(ru) Осторожно!

При проведении описанных процедур может возникнуть необходимость демонтировать или заменить детали. Для обеспечения надлежащих зазоров и вывода тока утечки, соблюдайте все инструкции по монтажу.

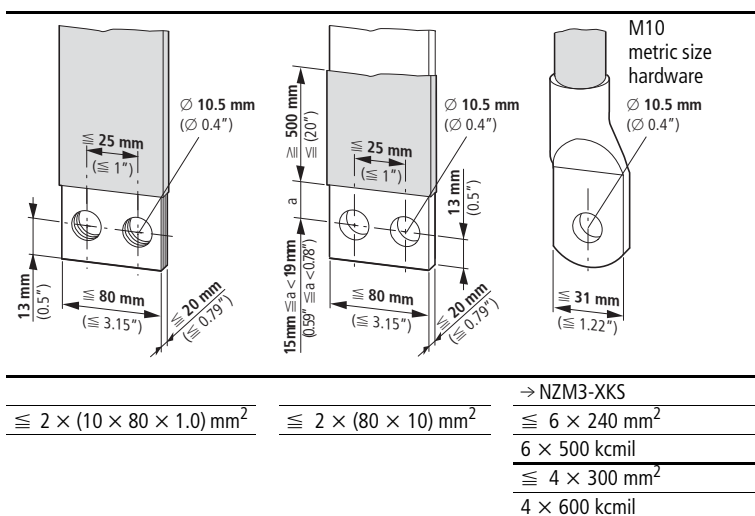
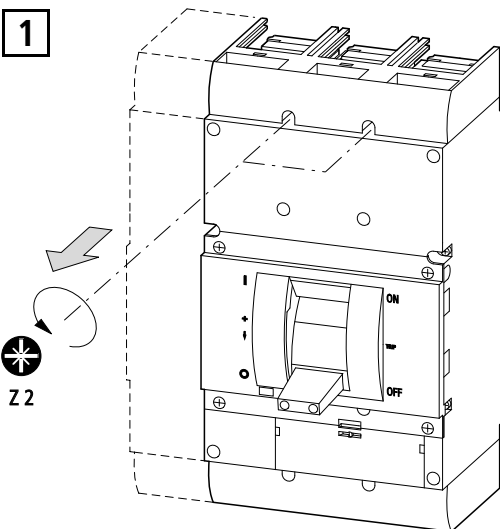

1

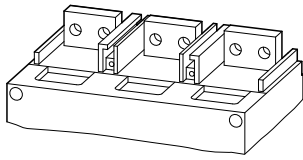

2

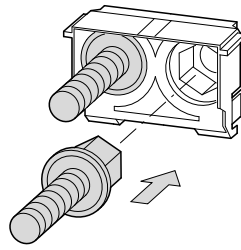

3

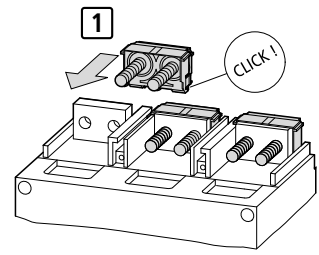

M10 metric size hardware, provided with all kits, connects to double hole per phase configuration on NZM4 breaker or switch.

4

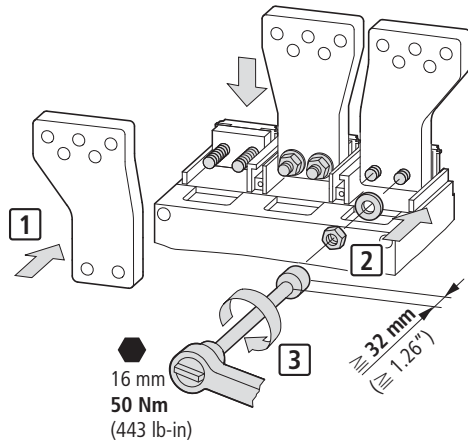

5

NZM4-XKP Phase Barriers (supplied)

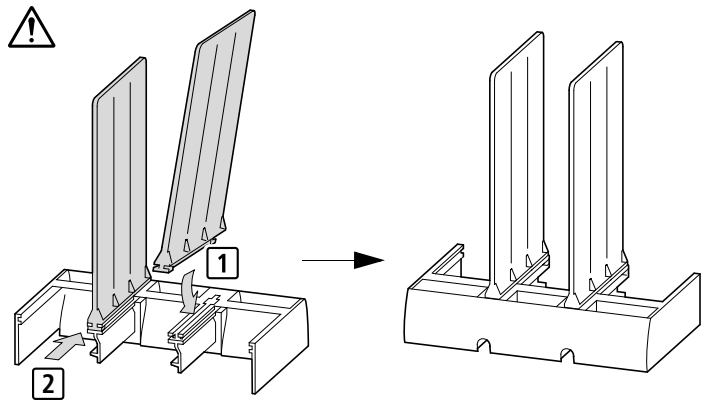

6

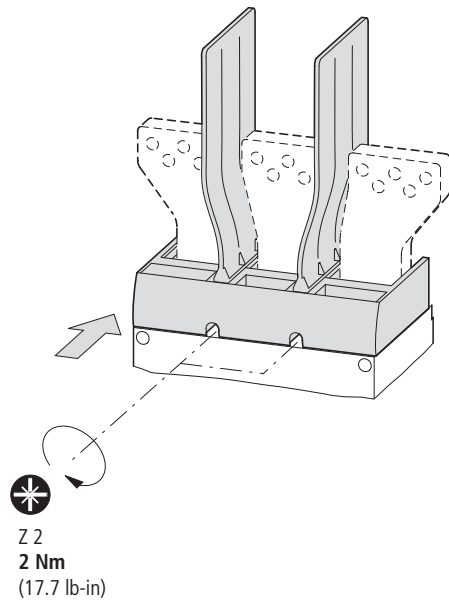

Warning! Use of the NZM4-XKP Phase Barriers (supplied) is required at all times to maintain proper electrical clearances when using any of the NZM4-XKV... Extended Width Connectors Plates.

11/10 IL01210014Z