

BreakerVisu – Hardware

NZM-XMC-MDISP35-MOD

NZM-XMC-MDISP35-SWD

NZM-XMC-MDISP70



Powering Business Worldwide

All brand and product names are trademarks or registered trademarks of the owner concerned.

Emergency On Call Service

Please call your local representative:

<http://www.eaton.eu/aftersales>

or

Hotline of the After Sales Service:

+49 (0) 180 5 223822 (de, en)

AfterSalesEGBonn@eaton.com

Original Operating Instructions

The German-language edition of this document is the original operating manual.

Translation of the original operating manual

All editions of this document other than those in German language are translations of the original German manual.

1st edition 2014, edition date 02/14

2nd edition 2014, edition date 12/14

3rd edition 2016, edition date 02/16

4th edition 2016, edition date 11/16

© 2014 by Eaton Industries GmbH, 53105 Bonn

Production: Antje Panten-Nonnen

Translation: globaldocs GmbH

All rights reserved, including those of the translation.

No part of this manual may be reproduced in any form (printed, photocopy, microfilm or any other process) or processed, duplicated or distributed by means of electronic systems without written permission of Eaton Industries GmbH, Bonn.

Subject to alteration without notice.



Danger! **Dangerous electrical voltage!**

Before commencing the installation

- Disconnect the power supply of the device.
- Ensure that devices cannot be accidentally restarted.
- Verify isolation from the supply.
- Earth and short circuit.
- Cover or enclose neighbouring units that are live.
- Follow the engineering instructions (AWA/IL) of the device concerned.
- Only suitably qualified personnel in accordance with EN 50110-1/-2 (VDE 0105 Part 100) may work on this device/system.
- Before installation and before touching the device ensure that you are free of electrostatic charge.
- The functional earth (FE) must be connected to the protective earth (PE) or to the potential equalisation. The system installer is responsible for implementing this connection.
- Connecting cables and signal lines should be installed so that inductive or capacitive interference does not impair the automation functions.
- Install automation devices and related operating elements in such a way that they are well protected against unintentional operation.
- Suitable safety hardware and software measures should be implemented for the I/O interface so that a line or wire breakage on the signal side does not result in undefined states in the automation devices.
- Ensure a reliable electrical isolation of the low voltage for the 24 volt supply. Only use power supply units complying with IEC 60364-4-41 (VDE 0100 Part 410) or HD 384.4.41 S2.
- Deviations of the mains voltage from the rated value must not exceed the tolerance limits given in the specifications, otherwise this may cause malfunction and dangerous operation.
- Emergency stop devices complying with IEC/EN 60204-1 must be effective in all operating modes of the automation devices. Unlatching the emergency-stop devices must not cause restart.
- Devices that are designed for mounting in housings or control cabinets must only be operated and controlled after they have been installed with the housing closed. Desktop or portable units must only be operated and controlled in enclosed housings.
- Measures should be taken to ensure the proper restart of programs interrupted after a voltage dip or failure. This should not cause dangerous operating states even for a short time. If necessary, emergency-stop devices should be implemented.
- Wherever faults in the automation system may cause damage to persons or property, external measures must be implemented to ensure a safe operating state in the event of a fault or malfunction (for example, by means of separate limit switches, mechanical interlocks etc.).

Contents

0	About this manual	3
0.1	Target group.....	3
0.2	List of revisions	3
0.3	Additional documentation	3
0.4	Writing conventions	5
0.4.1	Hazard warnings of material damages	5
0.4.2	Hazard warnings of personal injury	5
0.4.3	Tips.....	5
1	Description of device	7
1.1	Supported devices	7
1.2	Device models	8
1.3	Topology.....	9
1.4	Wiring diagram	10
1.5	Terminal markings.....	11
1.6	Marine approvals.....	12
1.7	Equipment supplied	13
1.7.1	3.5" devices.....	13
1.7.2	7.0" device.....	13
1.8	Nameplate.....	13
1.9	Maintenance and Inspection	13
1.9.1	Cleaning the resistive touchscreen	14
1.9.2	Recalibrating the resistive touchscreen	14
1.9.3	Battery.....	14
1.10	Repair	14
1.11	Storage.....	14
1.12	transport.....	15
1.13	Service and warranty.....	15
1.14	Disposal.....	15
1.15	Device-specific hazards.....	16

Contents

2	Installation.....	17
2.1	Area of application	17
2.2	Underwriters Laboratories Inc. (UL) requirements (UL).....	17
2.3	Conditions for marine approval (DNV GL)	17
2.4	Installation position	18
2.5	Interfaces.....	20
2.5.1	Preparing the cables with the SUB-D plug.....	22
2.5.2	Power supply	23
2.5.3	Ethernet	26
2.5.4	USB Device.....	27
2.5.5	USB Host	27
2.5.6	SmartWire-DT Master.....	27
2.5.7	POW/AUX (power supply for SmartWire-DT)	28
2.5.8	RS485	32
2.6	Mounting	34
2.6.1	Mounting the device	35
2.6.2	Screening the communication cables used	36
3	Operation.....	37
3.1	Start Device	37
3.2	Switch off the device	37
3.3	Inserting and removing the SD card	38
4	Appendix.....	39
4.1	Troubleshooting	39
4.2	Technical data	40
4.3	Dimensions	44
	Alphabetical index	45

0 About this manual

0.1 Target group

The content of the manual is written for engineers and electricians. A specialist knowledge of electrical engineering is needed for commissioning.



CAUTION

Installation requires qualified electrician

0.2 List of revisions

The following table only lists major modifications.

Publication date	Page	Keyword	New	Modification	Omitted
02/14		New edition	✓		
11/16		Marine approvals	✓		

0.3 Additional documentation

The following documents may also come in handy:

Manuals

- MN01210001Z-EN: "BreakerVisu – Software"
- MN05006001Z-EN: "SmartWire-DT module IP20"
- MN05006002Z-EN: "SmartWire-DT The System"
- MN0120006Z-EN: "SmartWire-DT module IP67"
- MN05013002Z-EN: "SmartWire-DT Gateway"
- MN01219001Z-EN: "Measuring and communication module NZM-XMC"
- MN05011007Z-EN: "System description Windows CE"

Instruction leaflets

- IL048002ZU: NZM-XMC-MDISP35-MOD, NZM-XMC-MDISP35-SWD, NZM-XMC-MDISP70
- IL 01219006Z: Measuring and communication module NZM-XMC
- IL05006005Z: NZM-XSWD-704
- IL01301001G: NRX Trip Units, Type U
- IL01301034: NRX MCAM Module

0 About this manual

0.3 Additional documentation



The aforementioned documentations, as well as the manual you are reading right now, can also be downloaded free of charge from the Internet in PDF format at:

<http://www.eaton.eu/> → **Customer support** → **Download Center – Documentation**

Shortlink: www.eaton.eu/doc

Enter the document number (e.g. "001210001Z") into the **Quick Search** text field.



Comprehensive and up-to-date information can be found at:

- www.eaton.eu/swd
- www.eaton.eu/xv
- www.eaton.eu/nzm
- www.eaton.eu/breakervisu

0.4 Writing conventions

Symbols with the following meaning are used in this manual:

- ▶ Indicates instructions to be followed.

0.4.1 Hazard warnings of material damages

NOTICE

Warns about the possibility of material damage.

0.4.2 Hazard warnings of personal injury



CAUTION

Warns of the possibility of hazardous situations that may possibly cause slight injury.



WARNING

Warns of the possibility of hazardous situations that could result in serious injury or even death.



DANGER

Warns of hazardous situations that result in serious injury or death.

0.4.3 Tips



Indicates useful tips.



In order to make it easier to understand some of the figures included in this manual, the variable frequency drive housing, as well as other safety-relevant parts, has been left out. However, it is important to note that the variable frequency drive must always be operated with its housing in its proper place, as well as with all required safety-relevant parts.



All the specifications in this manual refer to the hardware and software versions documented in it.



More information on the devices described here can be found on the Internet under: www.eaton.eu

0 About this manual
0.4 Writing conventions

1 Description of device

BreakerVisu displays can be used to visualize and log circuit-breaker and measuring device data. They are designed to show all the operational data of connected circuit-breakers and measuring devices in a clearly laid-out and easy-to-understand manner.

The displays use Modbus RTU or SmartWire-DT to collect, visualize, and log the data from multiple devices (for logging purposes, data is stored on an SD card included with the display). The displays are available in sizes of 3.5" and 7.0".

1.1 Supported devices

BreakerVisu displays support the following devices:

- NZM and NZM-MC compact circuit-breakers
- Air circuit-breakers IZMX16, IZMX40 of the series NRX
- Air circuit-breakers of series IZM26
- Measuring and communication module NZM-XMC
- NZMXMC-TC-MB transducer module
- Modbus RTU-capable third-party devices, with the use of the import function

Following is a list of the specific devices that can be used in connection with BreakerVisu displays:

Table 1: Compatible devices

Part no.	Article no.	description
NZM-XMC-TC-MB	169832	Transducer module
NZM-XSWD-704	135530	SmartWire-DT card for NZM switches
NZM-XSWD-707	172381	SmartWire-DT card for NZM switches
NZM-XMOD-707	172380	Modbus RTU interface module
IZMX-MCAM	122892	Modbus card for NRX series
IZM-MMINT	124236	Modbus card for IZM26 switches
NZM2-XMC-MB-250	156641	XMC measuring and communication module up to 250 A
NZM2-XMC-MB	129961	XMC measuring and communication module up to 300 A
NZM3-XMC-MB	129962	XMC Measuring and communication module up to 500 A
NZM3-XMC-KIT-630	153141	XMC measuring and communication module up to 630 A
NZM2-4-XMC-MB-250	156642	XMC measuring and communication module rated for currents of up to 250 A, 4-pole
NZM2-4-XMC-MB	129965	XMC measuring and communication module rated for currents of up to 300 A, 4-pole
NZM3-4-XMC-MB	129966	XMC measuring and communication module rated for currents of up to 500 A, 4-pole
NZM-XMC-AC	129968	XMC power supply, 24 V to 230 V
NZM-XMC-USB485	158562	XMC USB-to-RS-485 converter for configuring parameters

1 Description of device

1.2 Device models



At least one type U or type P trip block is required for the NRX and IZM26 circuit-breaker series. An electronic release is required for NZM circuit-breakers in SmartWire-DT networks.

1.2 Device models

BreakerVisu touch displays are available in the following models (display sizes):

Device	communication interface
Resistive touch 3.5" TFT LCD, 64k colors, QVGA	
NZM-XMC-MDISP35-MOD	<ul style="list-style-type: none">• RS485• RJ45 Ethernet
NZM-XMC-MDISP35-SWD	<ul style="list-style-type: none">• SmartWire-DT• RJ45 Ethernet
Resistive touch 7.0" TFT LCD, 64k colors, WVGA	
NZM-XMC-MDISP70	<ul style="list-style-type: none">• RS485 (galvanically isolated)• SmartWire-DT• RJ45 Ethernet• USB Host

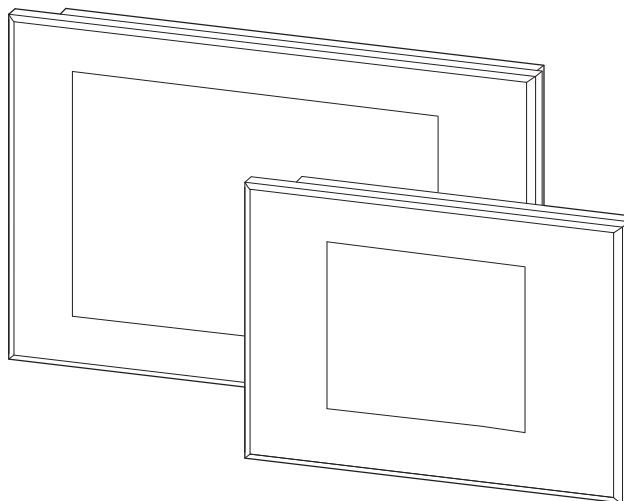

Figure 1: Device models (schematic)

1.3 Topology

The figure below shows the BreakerVisu system's wiring topology.

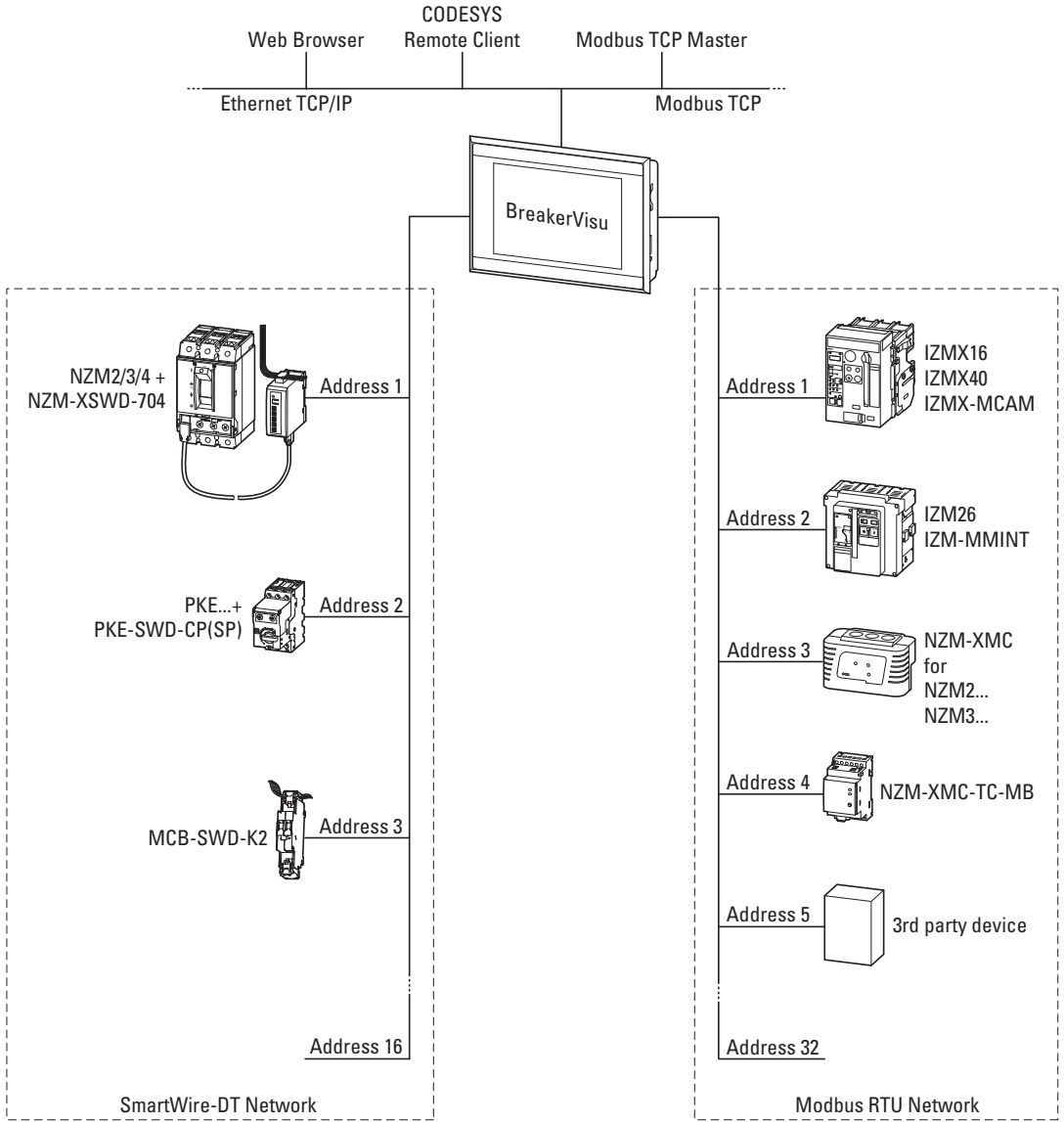

Figure 2: Topology

1 Description of device

1.4 Wiring diagram

1.4 Wiring diagram

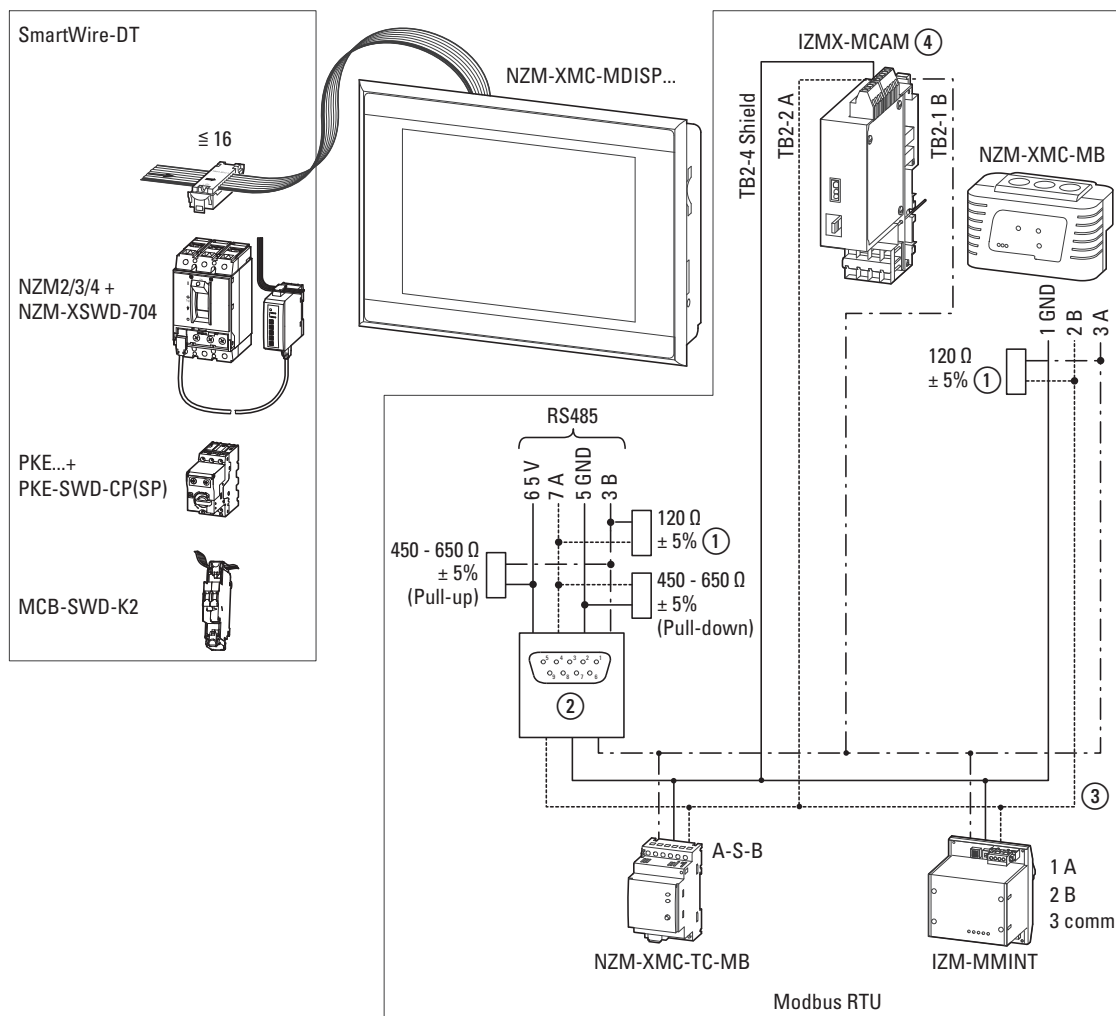

Figure 3: Wiring diagram

- ① Bus termination resistor
- ② Sub-D socket: Phoenix Contact SUBCON-PLUS F2 (recommended)
- ③ Lapp Kabel UNITRONIC® BUS LD Modbus and CAN cable (2 x 2 x 0.22) (recommended)
- ④ Modbus B must be routed to IZMX-MCAM terminal A



Wiring must be done on-site.
There are no prefabricated cables available.

1.5 Terminal markings

Due to the existence of various Modbus conventions, designations A, B, +, - are not always clear or standardized. Table 2 lists various Eaton devices and third-party devices, as well as the resulting terminal combinations.

Table 2: Overview of terminal designations on Modbus RTU devices

Part no.	Modbus connection #1 / terminal designation	Modbus connection #2 / terminal designation
NZM-XMC-MDISP...	B+ /3	A- /7
IZMX-MCAM	B+ /TB2-1	A- /TB2-2
IZM-MMINT	A+ /1	B- /2
NZM-XMC-MB	A+ /3	B- /2
NZM-XMC-TC-MB	A / A	B / B
Eaton EPBMETER	A+ /+	B- / B-
Eaton EMECMODB	A+ /9	B- /8
Eaton PowerXL DC1	A+ /8	B- /7
Nemo 96HDLe	A+ /+	B- /-

1 Description of device

1.6 Marine approvals

1.6 Marine approvals

Obtained type approvals

The touch displays NZM-XMC-MDISP... have been granted the required shipping classification by Det Norsk Veritas / Germanischer Lloyd (DNV GL)



- DNVGL-CG-0339 type approval, November 2015 edition, "Environmental test specification for electrical, electronic and programmable equipment and systems"
Certificate No.: TAA00000NC

Location classes

Temperature	B - Ambient temperature: 0°C to +55°C
Humidity	B - Relative humidity up to 100 % at all relevant temperatures.
Vibration	A - Bulkheads, beams, deck, bridge, Acceleration amplitude: 0.7 g
EMC	B* - All locations (including bridge and open deck)
Input	Required protection according to DNV-GL Rules shall be provided upon installation on board

* Filters / Ferrites maybe required to fulfil. See installation restrictions

Installation restrictions

- Installation and commissioning as indicated in the documentation for the touch display
- Shielded communication cables improve EMC behavior
- PE connection of communication cables improve EMC behavior (e.g. earth-connection kit: EATON ZB4-102-KS1)

<i>Location class</i>	<i>interface</i>	<i>Installation</i>
EMC B	Power supply	Place noise filter
	Ethernet	Place the ferrite core or snap-together ferrites at a max. distance of 20 cm from the external device plug.
	SmartWire-DT communication	
	SmartWire-DT power supply	
	RS485	
	RS232	

1.7 Equipment supplied

1.7.1 3.5" devices

- NZM-XMC-MDISP35-MOD or NZM-XMC-MDISP35-SmartWire-DT display
- 4 x mounting brackets with grub screw for flush mounting
- Sealing profile for flush mounting the device (glued in place on the device)
- Power supply connector for device
- SD memory card
- With NZM-XMC-MDISP35-SmartWire-DT only:
Power supply connector for SmartWire-DT master

1.7.2 7.0" device

- NZM-XMC-MDISP70 display
- 8 x mounting brackets with grub screw for flush mounting
- Sealing profile for flush mounting the device (glued in place on the device)
- Power supply connector for device
- SD memory card
- Power supply connector for SmartWire-DT master

If necessary, you can order stylus pens in groups of 10 (ACCESSORIES-RES-TOUCH-PEN-10, article no.. 139808), as well as other accessories. Please contact your distributor.

1.8 Nameplate

The device has a nameplate on rear. This nameplate makes it possible to identify the device and includes the following information:

- Manufacturer address
- Part no.
- Required power supply
- Article No. (part No. or article No.)
- Serial no.
- Date of manufacture (week/year)
- Certification marks and information concerning the corresponding certifications/approvals
- Layout of ports/interfaces and controls
- Permitted mounting positions ("top" edge)

1.9 Maintenance and Inspection

Resistive touch devices do not require maintenance.

However, they may require the following tasks to be carried out:

- Cleaning the resistive touchscreen when soiled.

1 Description of device

1.10 Repair

- Recalibrating the resistive touchscreen if it stops responding correctly to touch.

1.9.1 Cleaning the resistive touchscreen

Carefully clean the resistive touchscreen with a clean, soft, damp cloth. If there are any spots that are proving difficult to get off, spray a little dishwashing liquid on the damp cloth first.



CAUTION

The device can be damaged by pointy or sharp objects, as well as by liquids.

Do not use any pointy or sharp objects (e.g., knives) to clean the device.

Do not use aggressive or abrasive cleaning products or solvents. Make sure that no liquids get into the device (short-circuit hazard).

1.9.2 Recalibrating the resistive touchscreen

The resistive touchscreen will already be calibrated when you receive it. However, it will have to be recalibrated if it stops responding correctly to touch.



For more information on how to calibrate the touchscreen, please consult document MN05010007Z-EN, "Windows CE System Description."

1.9.3 Battery

The battery (→ Chapter 4, „Appendix“, Page 41) in the device cannot be replaced.

1.10 Repair

The device should only be opened by the manufacturer or by an authorized repair center.

For repairs, please contact your distributor or Eaton's Technical Support.

1.11 Storage

The ambient conditions (→ Chapter 4, „Appendix“, Page 41) for storage need to be met.

1.12 transport

When transporting or shipping the device, make sure that it is not damaged (use appropriate packaging).

All ambient conditions need to be met during transportation and shipping as well. Check the device for transit damage after arrival.

1.13 Service and warranty

In the unlikely event that you run into a problem with your Eaton BreakerVisu display, please contact your local sales office.

When you call, please have the following information ready:

- The exact part No. (see the information on the nameplate)
- the date of purchase
- A detailed description of the problem

Information concerning the guarantee can be found in the Terms and Conditions Eaton Industries GmbH.

24-hour hotline: +49 (0) 180 5 223 822

e-mail: AfterSalesEGBonn@Eaton.com

1.14 Disposal

Devices no longer being used must be professionally disposed of as per local regulations or returned to the manufacturer or the relevant sales office.



DANGER

Explosive and toxic materials

The lithium battery soldered inside the device may explode if handled incorrectly.

Materials used in the device

Table 3: Device materials

Assembly part	Material characteristic
Housing	PC-GF
Resistive touch protective screen	Glass with polyester layer
Battery	CR2032 lithium battery, 3.0 V, 220 mAh, Panasonic
• Battery weight	3.4 g
• SVHC substance	1.2-dimethoxyethane: ethylene glycol dimethyl ether (EGDME)
• Substance weight	2-4 %
Electrical components	Various

1 Description of device

1.15 Device-specific hazards

Materials used in the packaging

Table 4: Packaging materials

Assembly part	Material characteristic
Outer packaging	Cardboard
3.5" devices	<ul style="list-style-type: none"> • Cardboard with PE sheet • Plastic bag: polyethylene (PE)
7.0" devices	<ul style="list-style-type: none"> • Cardboard • Plastic bag: polyethylene (PE)

1.15 Device-specific hazards



DANGER **EXPLOSION HAZARD**

Death, serious injury, and property damage may occur if the device is being used in a potentially explosive (classified) location and, during operation, an electrical plug-in connection is disconnected or the device is exposed to dangerous impacts or other types of dangerous mechanical shock.

Use the device in the following environments only:

- Non-hazardous (non-explosive) areas
- Zone 22 hazardous areas (as per ATEX Directive 94/9/EC)

Do not expose the device to any dangerous impacts or other types of dangerous mechanical shock!

Do not operate the device in hazardous (classified) locations unless it is mounted correctly!

De-energize the device before disconnecting plug-in connections!



DANGER **LIVE PARTS INSIDE THE DEVICE**

When the device is open, there will be an electric shock hazard if live parts are touched.
Do not open the device!



DANGER **STRAY CURRENTS**

Large transient currents between the protective circuits of different devices may result in fire or in malfunctions due to signal interference.

If necessary, route an equipotential bonding conductor, with a cross-sectional area that is several times larger than that of the cable screen, parallel to the cable.

2 Installation

2.1 Area of application

- The device must be used exclusively in locations for which it has been approved/certified. For more information, please refer to the markings on the nameplate and to → Section 4.2, „Technical data“, page 40.
- A steady power supply must be ensured (→ Page 42).

2.2 Underwriters Laboratories Inc. (UL) requirements (UL)

Underwriters Laboratories Inc. (UL) certification as per the UL 508 standard requires for the following technical conditions to be met:

Environmental conditions

- Maximum ambient air temperature: 50 °C
- Degree of pollution 2

Moment of torque

The torque used to tighten the screw terminals on the plug-in connection for the power supply must not exceed 0.6 - 0.8 Nm (5 - 7 lb·in).

Devices with SmartWire-DT: overcurrent and short-circuit protection

The SmartWire-DT master interface's U_{Aux} supply voltage must be externally protected against overcurrent and short-circuits with the following:

- Miniature circuit-breaker 24 V DC, rated operational current 2 A, trip type Z.
- Or a 2 A fuse

2.3 Conditions for marine approval (DNV GL)

The following DNV GL rules for shipping classification in accordance with DNVGL-CG-0339 type approvals must be observed:

1. Complete and proper installation and commissioning in accordance with DNV GL rules and Eaton requirements and specifications.
2. Installation of radio interference suppression filters for the 24 V DC supply.
3. Screening the communication cables used.

2 Installation

2.4 Installation position

2.4 Installation position

The device is intended to be flush mounted in control cabinets, control panels, or control consoles. It can be installed in portrait or landscape mode.

When selecting the mounting location, take the following into account:

- Do not expose the device to direct sunlight or to lamps with UV radiation (the device's plastic components may become brittle when exposed to UV light, which will reduce the device's lifespan).
- If you will be using the device in a hazardous (explosive) location, make sure it is not exposed to any dangerous impacts or other types of dangerous mechanical shock.
- If no forced ventilation is being used, the device must not be mounted at an angle of more than $\pm 45^\circ$ relative to its fully vertical position.
- The controls on the device's operating side, as well as the cable connections, must remain accessible once the device has been mounted.
- The required ambient conditions must be met (→ Page 41).
- Adequate ventilation (cooling) must be ensured:
 - There must be a clearance of at least 3 cm around the vents
 - The device must be at a clearance of at least 15 cm from assembly parts that radiate heat, such as transformers under heavy load
 - The temperature range should not exceed an admissible range of 0 to 50 °C
- Mounting surface characteristics:
 - Material thickness at the mounting cutout: 2 - 5 mm
 - Unevenness ≤ 0.5 mm (with the device already mounted as well)
 - Surface roughness $R_z \leq 120$



DANGER

Stray currents

Large transient currents between the protective circuits of different devices may result in fire or in malfunctions due to signal interference.

If necessary, route an equipotential bonding conductor, with a cross-sectional area that is several times larger than that of the cable screen, parallel to the cable.



CAUTION

Interference

The values specified in the technical data and the device's electromagnetic compatibility (EMC) cannot be guaranteed if unsuitable cables, improperly assembled and terminated cables, and/or unprofessional wiring are used.

Only use cables assembled and terminated by professionals.

The cables being used must be assembled and terminated as required by the port/interface description in this document.

When wiring the device, follow all instructions regarding how to wire the corresponding port/interface.



CAUTION

Non-galvanically isolated interfaces

The device may be damaged by potential differences.

The GND terminals of all bus modules must be connected.



CAUTION

Installation requires qualified electrician

2.5 Interfaces

The ports/interfaces will depend on the specific device model (→ nameplate and → Section 1.2, „Device models“, page8).

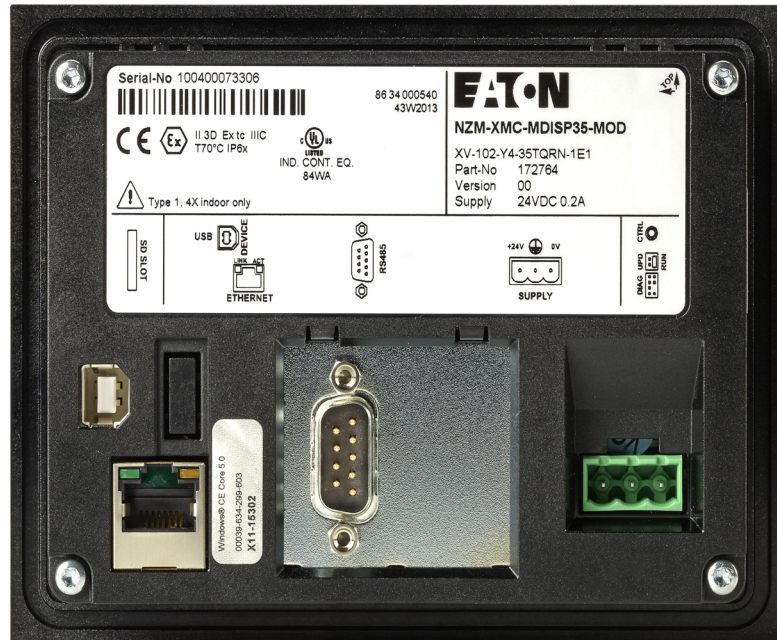

Figure 4: Back of 3.5" device (Modbus RTU)

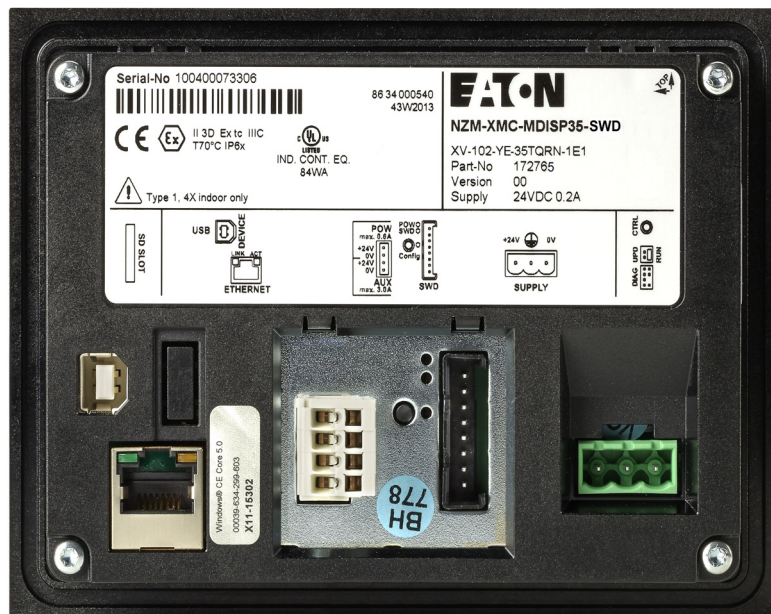

Figure 5: Back of 3.5" device (SmartWire-DT)

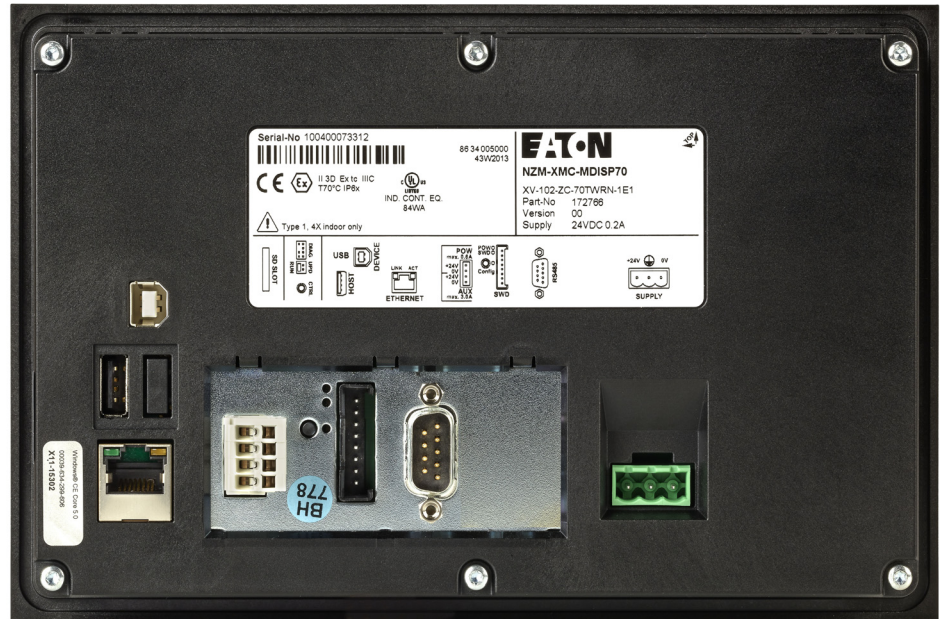

Figure 6: Back of 7.0" device (Modbus RTU & SmartWire-DT)

2.5.1 Preparing the cables with the SUB-D plug

The way the bus is wired plays an essential role in ensuring that the device will work properly, as well as in its electromagnetic compatibility (EMC).

2.5.1.1 Wiring requirements

- The cables must be screened.
- The cable screen must consist of a copper braid.
- The cable screen must be terminated to the connector shell with a low-impedance bond across a large area.
To do this, use metal or metallized connector shells with a strain relief. The strap must be tightly screwed together with the plug.

2.5.1.2 Connecting the cable screen

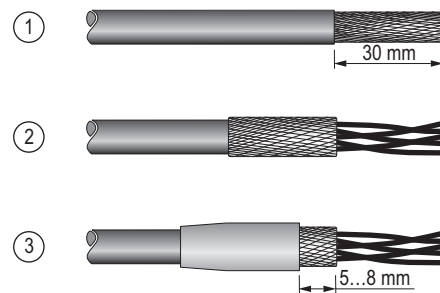

Figure 7: Connecting the cable screen

- ▶ Insulate the cable end so that approx. 3 cm of screen braid is exposed (1).
- ▶ Fold back the screen braid over the cable sheath (2).
- ▶ Shrink heat-shrink tubing with a length of approx. 3 cm around the folded screen braid end or use a rubber grommet. The screen braid must remain exposed 5 to 8 mm at the end of the cable. The folded screen braid end must be covered by the heat-shrink tubing or the rubber grommet (3).
- ▶ Terminate the end of the cable with the D-sub plug:
The bare screen braid must be clamped onto the connector shell together with the strain relief.

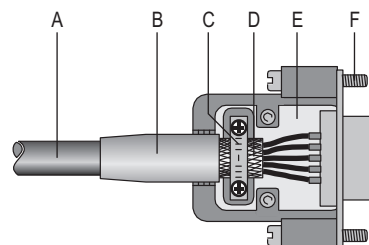

Figure 8: Cable with prefabricated D-sub plug

- A Cable with cable sheath
- B Heat-shrink tubing or rubber grommet
- C Strap
- D Screen braid

- E D-Sub plug
- F Fixing screw UNC

NOTICE

The EMC (immunity and emissions) values specified in the device's technical data can only be guaranteed if the required cable assembly, cable termination, and wiring are used!

2.5.2 Power supply

The device has an internal fuse and protection against polarity reversal. The functional earth is connected to the connector cover only, and not to 0 V. The housing is made of plastic and is potential-free. The device's power supply is not galvanically isolated.

The device requires a power supply of 24 V DC from an AC-DC converter with safe SELV isolation (SELV = safety extra low voltage – circuit in which no dangerous voltages will be produced under single-fault conditions).

For additional properties concerning the power supply required, please refer to → Page 42.



Figure 9: Power supply interface

2 Installation

2.5 Interfaces

2.5.2.1 Wiring

A Phoenix Contact MSTB 2.5/3-ST-5.08 (Phoenix article No. 1757022) plug connector is included with the device.

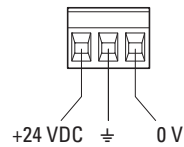

Figure 10: Phoenix Contact MSTB 2.5/3-ST-5.08 plug connector (view from wiring side)

Table 5: Plug connection configuration

Connection	Configuration
+24 V DC	Supply voltage +24 V DC
⊕	Functional earth connected to connector cover – does not need to be connected. If required due to the installation environment, this connection can be used as a protective earth connection.
0V	Supply voltage 0 V

Observe the following when preparing the wiring of the plug connector:

Table 6: Terminating the wiring with the plug connector

Feature	Description/Value
Terminal type:	Plug-in screw terminal
Cross section	0.75 - 2.5 mm ² (drain wire or conductor) AWG18 - AWG12
Strip length	7 mm
Max. tightening torque	0.6 - 0.8 Nm (5 - 7 Lb.In.)

2.5.2.2 Radio interference suppression filter for the 24 V DC supply

Additional interference filters must be installed for the power supply in order to adhere to the EMC B provisions.

- ▶ Integrate a radio interference suppression filter into the wiring.

Depending on the output, the following filters can be used:

- XT-FIL-1 radio interference suppression filter for 24 V DC supply up to 2.2 A (Eaton article no. 285316) or
- XT-FIL-2 radio interference suppression filter for 24 V DC supply up to 12 A (Eaton article no. 118980)

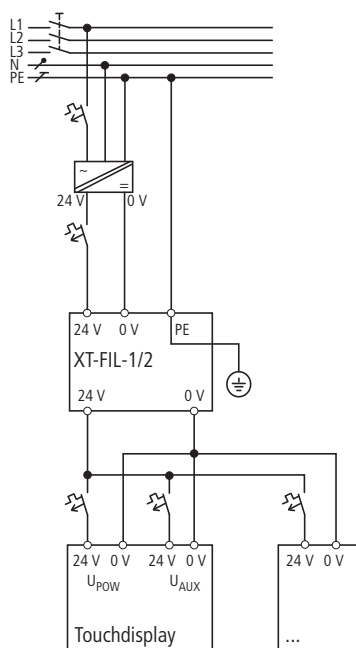

Figure 11: Power supply with EMC filter
Grounding is ensured either by using

- the filter's integrated contact fields onto a grounded metal plate
- or using
- a separate line to the filter's PE connection.

Depending on the current consumption or configuration, several filters may be used as well.

2 Installation

2.5 Interfaces

2.5.3 Ethernet



Figure 12: Ethernet interface (RJ45 socket)

Table 7: Indicator LEDs on the Ethernet interface

LED	Description
ACT (yellow) – flashing	Ethernet is active (data transfer)
LINK (green) – solid light	Active network connected and detected.

2.5.3.1 Cable

Use a screened twisted pair cable (STP) for wiring.

- For device-to-device connections:
Crossover cable
- For the connection to the hub/switch:
1:1 patch cord

The maximum cable length is 100 m.



CAUTION

Forces on the Ethernet interface

Communications may be affected, and the connection's mechanical components may be damaged, if the Ethernet interface is subjected to strong vibrations or the RJ45 plug-in connection is subjected to pulling.

Protect the RJ45 plug-in connection from strong vibrations!
Protect the RJ45 plug-in connection from tensile forces at the socket!

2.5.4 USB Device

The USB device interface supports the USB 2.0 standard.



Figure 13: USB device interface (USB device, Type B)

2.5.4.1 Cable

Use only shielded standard USB cables. The maximum cable length is 5 m.

2.5.5 USB Host

The USB host interface supports the USB 2.0 standard.



Figure 14: USB host interface (USB host, Type A)

Use only shielded standard USB cables.
The maximum cable length is 5 m.

2.5.6 SmartWire-DT Master

The SmartWire-DT master interface is not galvanically isolated.



CAUTION

The device may be damaged by potential differences.
Provide a common star point for the earth wiring.

2.5.6.1 Operating and indication elements of the SmartWire-DT master interface

The image below shows the ports for a SmartWire-DT master interface.

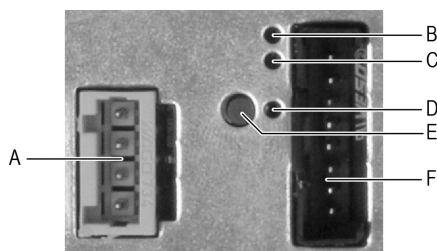

Figure 15: SmartWire-DT master interface

2 Installation

2.5 Interfaces

Table 8: Operating and indication elements of the SmartWire-DT master interface

Interface	Description
A POW/AUX interface	Power supply interface for SmartWire-DT → Section 2.5.7, „POW/AUX (power supply for SmartWire-DT)“, page28
B POW-LED	Lights up when the SmartWire-DT network is powered.
Cc SWD-LED	Indicates whether the physical configuration of the SmartWire-DT network matches the target configuration stored in the device. The configurations will be compared with each other every time the power is switched on. → Section 2.5.7.4, „Commissioning the SmartWire-DT network“, page30
D Config-LED	Indicates whether the SmartWire-DT master project configuration defined in the PLC matches the SmartWire-DT network target configuration stored in the device. The configurations will be compared with each other every time the power is switched on.
E Configuration button	Used to configure the SmartWire-DT network.
F SWD Interface	SmartWire-DT interface → Section 2.5.7.2, „SmartWire-DT interface“, page30

2.5.7 POW/AUX (power supply for SmartWire-DT)

The POW/AUX interface is not galvanically isolated.

The following power supplies are required for a SmartWire-DT network:

- **POW supply voltage:**
The device supply voltage for the electronics in the downstream SmartWire-DT modules (15 V DC) is generated using the 24 V DC supply voltage applied at the POW terminal.
- **AUX supply voltage:**
If there are any contactors or motor starters in the SmartWire-DT topology, a 24 V DC AUX voltage must be additionally supplied as a control voltage for the contactor coils.

The 24 V DC AUX supply voltage must be supplied in order to run the BreakerVisu.



For additional properties concerning the power supply required, please refer to → Chapter 4, „Appendix“, Page 42.

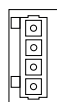

Figure 16: POW/AUX power supply interface

2.5.7.1 Wiring



The WAGO (article No. 734-104) plug connector is included with the device.

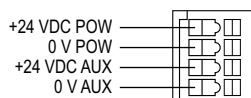

Figure 17: WAGO plug connector (view from wiring side)

Table 9: Plug connection configuration

Connection	Configuration
+24 V DC POW	Supply voltage U_{POW} +24 V DC
0 V POW	Supply voltage U_{POW} 0 V
+24 V DC AUX	Supply voltage U_{AUX} +24 V DC
0 V AUX	Supply voltage U_{AUX} +0 V

Observe the following when assembling and terminating the wiring for the plug connector:

Table 10: Wiring the plug connector

	Description/Value
Terminal type:	spring-cage terminal
Cross section	0.2 - 1.5 mm ² (connectable conductor, solid) AWG24 - AWG16
Strip length	6 -7 mm

External overcurrent and short-circuit protective device, implemented with a miniature circuit-breaker or a fuse, is required for U_{AUX} .

Table 11: Overcurrent and short-circuit protective device standards

Standard	Overcurrent and short-circuit protective device
DIN VDE 0641, Part 11 and IEC/EN 60898	Miniature circuit-breaker 24 V DC, rated operational current 3 A, trip type Z Fuse 3 A, utilization category gL/gG
UL 508 and CSA-22.2, No. 14	Miniature circuit-breaker 24 V DC, rated operational current 2 A, trip type Z Fuse 2 A

2.5.7.2 SmartWire-DT interface

The SmartWire-DT interface is not galvanically isolated.

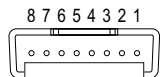

Figure 18: SmartWire-DT interface (pin header, 8-pin)

2.5.7.3 SWD line

Only use the following ribbon cables to connect the SmartWire-DT network to the SmartWire-DT interface:

- SWD4-100LF8-24 with the SWD4-8MF2 blade terminals or
- SWD-4-(3/5/10)F8-24-2S (prefabricated cable)



For detailed instructions on how to terminate the cable with the SWD4-8MF2 blade terminal, please refer to manual MN05006002Z-EN, "SmartWire-DT – The System".

2.5.7.4 Commissioning the SmartWire-DT network

The following requirements must be met before switching on the network after initial commissioning, replacement, or modifying the SmartWire-DT configuration:

- All SmartWire-DT modules must be connected to each other via SmartWire-DT cables.
- The SmartWire-DT network must be connected to the SmartWire-DT interface.
- The power supply for the device and for SmartWire-DT must be on and connected.
- The SmartWire-DT master's POW LED must be lit up with a solid light.
- The SmartWire-DT status LEDs of the connected SmartWire-DT modules must be flashing or showing a solid light.
- There must be a PLC project in which the SmartWire-DT master is configured (project configuration).
- The PLC runtime system must be installed on the device.

The BreakerVisu system will automatically start scanning for SmartWire-DT devices after starting.



Please refer to the MN0121001Z "BreakerVisu Software" manual as well (chapter 4, "Connecting devices to SmartWire-DT").

- All SmartWire-DT modules are addressed.
- The SmartWire-DT network's physical configuration will be stored in the device's non-volatile memory as a target configuration.
- The SmartWire-DT master interface's SWD LED will start showing a solid green light.

2.5.7.5 Configuration tests

The configuration will be checked every time the supply voltage is switched on:

- The modules that are actually on the network will be compared with the target configuration stored on the device:
If the SmartWire-DT network's physical configuration matches the target configuration, the SmartWire-DT network will be ready to start transferring data.
- The target configuration stored in the device will be compared with the project configuration defined in the PLC:
If the target configuration matches the project configuration, the **Config** LED will light up with a solid green light.

Table 12: SWD and Config LEDs

LED	status	Description
Smart-Wire-DT	off	No target configuration present
	Red continuous light	<ul style="list-style-type: none"> • Short-circuit on the 15 V DC power supply. • No SmartWire-DT module found.
	Red flashing	<ul style="list-style-type: none"> • The modules found in the SmartWire-DT network do not match the target configuration. • A SmartWire-DT module configured as necessary is missing.
	Flashing with an orange light	The SmartWire-DT network's physical configuration is being imported and stored as a new target configuration in the device.
	Green flashing	<ul style="list-style-type: none"> • The physical configuration of the SmartWire-DT network is compared with the target configuration. • The SmartWire-DT modules are addressed.
	Green continuous light	<ul style="list-style-type: none"> • The modules found in the SmartWire-DT network match the target configuration. • The SmartWire-DT network is ready for data exchange.
Config	off	<ul style="list-style-type: none"> • No project configuration present. • Incorrect target configuration (see LED SWD).
	Red continuous light	The project configuration and the stored target configuration are not compatible with each other.
	Green flashing	The project configuration is compatible with the stored target configuration.
	Green continuous light	The project configuration matches the stored target configuration

2.5.8 RS485

The 3.5" device's RS485 interface is not galvanically isolated; the 7" device's RS485 interface is galvanically isolated.



CAUTION

Non-galvanically-isolated interfaces
The device may be damaged by potential differences.
The GND terminals of all bus modules must be connected.

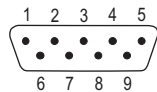

Figure 19: RS-485 interface (9-pin, male D-sub, UNC)

Table 13: RS-485 port pinout

Pin	signal	Configuration
1	–	Do not connect pin 1.
2	–	Do not connect pin 2.
3	B	Cable B
4	–	Do not connect pin 4.
5	GND	Ground
6	+5 V DC	for external bus termination
7	A	A cable
8	–	Do not connect pin 8.
9	–	Do not connect pin 9.

Bus termination RS485 Modbus

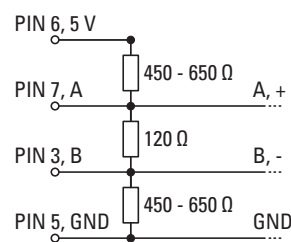

Figure 20: Bus termination RS485 Modbus

2.5.8.1 wiring

Screened twisted-pair cables must be used.

Table 14: Cable specification

Property	value
Rated cable impedance	120 Ω
Permissible impedance	108 -132 Ω
Max. cable length	1200 m
Possible baud rates	9600 Bit/s 19200 Bit/s 38400 Bit/s 57600 Bit/s 115200 Bit/s



When terminating the cable, make sure that there is a good low-impedance bond between the cable screen and the connector shell (→ Section 2.5.1, „Preparing the cables with the SUB-D plug“, page22).

2.5.8.2 RS485 topology

- A bus segment can connect a maximum of 32 nodes with each other.
- Several bus segments can be connected using repeaters (bi-directional amplifiers). This can be used to increase the maximum cable length. For more details, please consult the documentation provided by the repeater's manufacturer.
- A bus segment must be provided with cable termination (120 Ω) at both ends. These terminals must be connected in the plug directly between pin 3 and 7.
 - The bus segment must be terminated at both ends.
 - No more than two terminations must be provided for each bus segment.
 - Running the bus without the proper cable terminations may result in transmission errors.

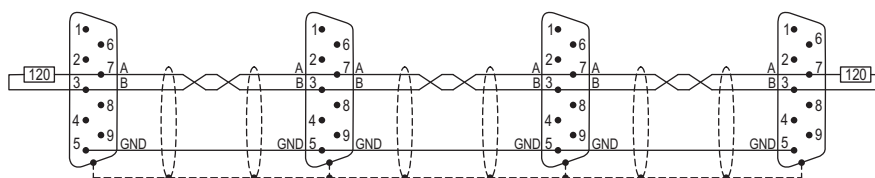

Figure 21: Bus segment with four nodes

2.6 Mounting



CAUTION

The values specified in the technical data and the device's electromagnetic compatibility (EMC) cannot be guaranteed if unsuitable cables, improperly assembled and terminated cables, and/or unprofessional wiring are used.

Only use cables prefabricated and terminated by professionals.

The cables being used must be assembled and terminated as required by the port/interface description in this document.

When wiring the device, follow all instructions regarding how to wire the corresponding port/interface.



CAUTION

Condensation in/on the device

If the device is or has been exposed to climatic fluctuations (temperature fluctuations, air humidity), condensation may form on or inside the device, creating a short-circuit hazard.

Do not switch on the device if there is condensation in or on it.

If the device has condensation in or on it, or if the device has been exposed to temperature fluctuations, let the device settle into the existing ambient temperature before switching it on (do not expose the device to direct thermal radiation from heating appliances).



Check the device for transit damage.

- ▶ Mount the device in the control cabinet, control panel, or control console (→ Section 2.6.1, „Mounting the device“, page35).
- ▶ Connect the device as required for your application.



Follow all instructions regarding how to wire the corresponding port/interface (→ Section 2.5, „Interfaces“, page20)



The device does not have an ON/OFF switch. If the power supply does not have a switch either, the device will start as soon as it is connected to the power supply.

2.6.1 Mounting the device

- ▶ Select the mounting location for the device by following the instructions in
→ Section 2.4, „Installation position“, page18.
- ▶ Make a mounting cutout for the device at the selected location:

Installation cut-out

3.5" devices: 123 x 87 mm (± 1 mm)

7.0" devices: 197 x 122 mm (± 1 mm)

Material thickness at mounting cutout: 2 - 5 mm

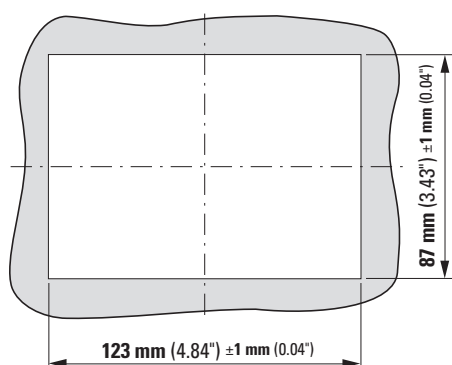

Figure 22: Mounting cutout for 3.5" devices

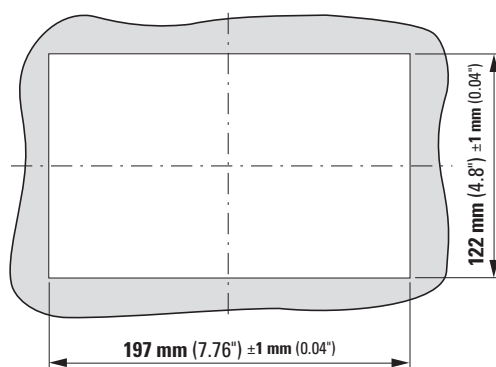

Figure 23: Mounting cutout for 7.0" device

- ▶ Insert the included set screws into the holding brackets: The end points of the set screws must point towards the wide ends of the holding brackets.



Figure 24: Set screw pre-assembled in holding bracket

2 Installation

2.6 Mounting

- ▶ Insert the device into the mounting cutout from the front.
- ▶ Hook the holding brackets into the corresponding device cutouts and secure the device by tightening the set screws until the front of the touch display is flush with the control cabinet's surface at the fixing points.

NOTICE

Tightening the set screws too tight may damage the device. Do not exceed a torque of 0.1 Nm when tightening the set screws.



The holding brackets' positions will depend on the device size and the installation requirements involved.



3.5" devices that need to meet IP65/NEMA 4X requirements when mounted will need a holding bracket at each of the **four** fastening points.

7.0" devices that need to meet IP65/NEMA 4X requirements when mounted will need a holding bracket at each of the **eight** fastening points.

2.6.2 Screening the communication cables used

In order to ensure that signals are transmitted without noise so as to comply with EMC B requirements, the communication cables used must be screened.

- Use screened cables or screen the cables yourself with a ferrite ring such as:
Würth STAR-RING snap-together ferrite, split ferrite core, 30 x 20 x 20 mm, for cables with a diameter of 8 mm
Würth STAR-GAP snap-together ferrite, split ferrite core, 31.5 x 35 x 28.3 mm, for cables with a diameter of 13 mm
- ▶ Make sure to properly place the ferrite ring on the communication cable at a location close to the connection side (max. distance of 20 cm from the external device plug) on the touch display.

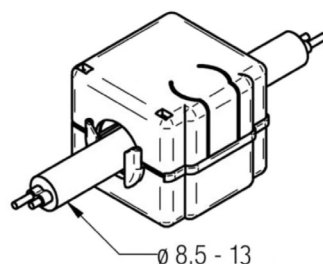

Figure 25: Screening with snap-together ferrite ring

3 Operation

NOTICE

The device's resistive touch surface is sensitive and can be damaged by pointy or sharp objects. Do not touch the surface with anything other than your fingers or a stylus pen. If you are wearing gloves, they must be clean and free of abrasive dust and particles.



CAUTION

Condensation in/on the device
If the device is or has been exposed to climatic fluctuations (temperature fluctuations, air humidity), condensation may form on or inside the device, creating a short-circuit hazard. Do not switch on the device if there is condensation in or on it. If the device has condensation in or on it, or if the device has been exposed to temperature fluctuations, let the device settle into the existing ambient temperature before switching it on (do not expose the device to direct thermal radiation from heating appliances).

3.1 Start Device

Once a power supply is applied, the display will start automatically with the following start screen.



Figure 26: Start screen



If the device does not start and/or if an error message is shown when the device starts, please refer to → Section 4.1, „Troubleshooting“, page 39.

3.2 Switch off the device

To switch off the device, remove the power from it.

3 Operation

3.3 Inserting and removing the SD card

3.3 Inserting and removing the SD card



Figure 27: SD slot ①



CAUTION

Data loss

If an SD card is being written to and a voltage drop occurs or the card is removed, data may be lost or the SD card may be ruined.

Insert the SD card only when the device is de-energized.

Avoid writing to SD cards as much as possible.

Reasons:

SD cards have a limited number of write cycles.

If there is a voltage drop while a write operation is in progress, data loss is highly likely to occur.

Remove the SD card only when the device is de-energized.

Before switching off the device, make sure that there are no programs writing to the SD card.



Do not use force!

SD cards cannot be inserted the wrong way around.

Inserting the SD card

- ▶ Push the SD card into the SD slot ① until you feel it lock into place.

Removing the SD card

- ▶ Push the SD card into the SD slot ① all the way to the stop. Release the interlock and slide the SD card a little bit out of the SD slot.
- ▶ Pull the SD card out of the SD slot.

4 Appendix

4.1 Troubleshooting

Table 15: Faults and fixes

Fault and possible cause	Remedy
The device will not start (boot up)	
There is no voltage at the power supply interface.	Check the input wiring.
The set screws used to mount the device are too tight.	Loosen the set screws (observe the maximum torque, → Section 2.6.1, „Mounting the device“, page35)
The device is faulty.	Send the device in for repairs.
The display stays or turns dark.	
The backlight is deactivated.	Check the function in the visualization software.
The backlight is faulty.	Send the device in for repairs.
The resistive touch is not responding or is responding incorrectly when used.	
The resistive touchscreen is not calibrated correctly.	<ul style="list-style-type: none"> • Start the device (boot it up). • Calibrate the resistive touchscreen (see manual MN05010007Z-EN).
The resistive touchscreen is disabled.	<ul style="list-style-type: none"> • Start the device (boot it up). • Calibrate the resistive touchscreen (see manual MN05010007Z-EN).
■ This icon appears in the task bar.	
The control elements shown on the display were used incorrectly.	Remove all objects (including fingers) from the display area.
The set screws used to mount the device are too tight.	Loosen the set screws (observe the maximum torque, → Section 2.6.1, „Mounting the device“, page35)
The device is faulty.	Send the device in for repairs.

4 Appendix

4.2 Technical data

4.2 Technical data

Technical data	Value NZM-XMC-MDISP35-...	Value NZM-XMC-MDISP70-...
General – standards		
EMC (relevant for CE)	IEC/EN 61000-6-2: Interference immunity for industrial environments IEC/EN 61000-6-4: Interference immunity for industrial environments Devices meeting this standard may not be used in residential areas. IEC/EN 61000-6-3: Emitted interference standard for residential, commercial and light-industrial environments Remark: Does not apply to devices with a SmartWire-DT master interface	
Explosion protection (relevant for CE)	ATEX 94/9/EC: Zone 22, Category 3D (II 3D Ex tc IIIC T70°C IP6x): EC/EN 60079-0: Explosive atmospheres: Devices - Specification for general requirements IEC/EN 60079-31: Explosive atmospheres: Equipment dust ignition protection by enclosure “t”	
safety		
	IEC/EN 60950 UL 60950 Safety of Information Technology Equipment	–
	UL 508 – Industrial Control Equipment	
Product standards	EN 50178: Electronic equipment for use in power installations IEC/EN 61131-2: Programmable logic controllers: Equipment requirements and tests	
Approvals and declarations		
emc	2004/108/EEC	
explosion safety	II 3D Ex tc IIIC T70°C IP6x (ATEX 94/9/EC): Zone 22, category 3D: IP5X for group IIIB devices (nonconductive dust) IP6X for group IIIC devices (conductive dust) Required amount of holding brackets and set screws for flush mounting: 4 of each	II 3D Ex tc IIIC T70°C IP6x (ATEX 94/9/EC): Zone 22, category 3D: IP5X for group IIIB devices (nonconductive dust) IP6X for group IIIC devices (conductive dust) Required amount of holding brackets and set screws for flush mounting: 8 of each
UL	Devices with gasket adhesively bonded in place: UL 508, file No. E205091 Required amount of holding brackets and set screws for flush mounting: 4 of each	Devices with gasket adhesively bonded in place: UL 508, file No. E205091 Required amount of holding brackets and set screws for flush mounting: 8 of each
Marine approvals	Type approval – provided that a radio interference suppression filter for the device is installed in the wiring and that the communication cables are screened. DNVGL-CG-0039, since 11/2015, Certificate No.: TAA00000NC	
Degree of protection		
Front	IP65, enclosure type 4X (indoor use only) Required amount of holding brackets and set screws for flush mounting: 4 of each	IP65, enclosure type 4X (indoor use only) Required amount of holding brackets and set screws for flush mounting: 8 of each
Rear side	IP20, enclosure type 1	
Measures and weights		
Width x Height x Depth	136 x 100 x 30 mm	210 x 135 x 38 mm
Thickness of front plate	5 mm	
Built-in depth	25 mm	33 mm

Technical data	Value	Value
	NZM-XMC-MDISP35-...	NZM-XMC-MDISP70-...
Mounting cutout	123 x 87 mm (±1 mm)	197 x 122 mm (±1 mm)
Weight	approx. 0.3 kg	approx. 0.6 kg
Environmental conditions		
temperature		
operation	0 - 50 °C	
Storage/transport	-20 - 60 °C	
Relative humidity	10 -95 %; non-condensing	
Vibration as per IEC/EN 60068-2-6	Displacement: 5 - 9 Hz: 3.5 mm, 9 - 60 Hz: 0.15 mm Acceleration: 60 - 150 Hz: 2 g	
Impact resistance as per IEC/EN 60068-2-27	15 g/11 ms	
Fall test	according to IEC/EN 60068-2-31	
Display		
Part no.	TFT-LCD	
Resolution (W x H)	QVGA (320 x 240 pixels)	WVGA (800 x 480 pixels)
Visible screen area	70 x 53 mm (3.5" diagonal)	152 x 91 mm (7.0" diagonal)
Color resolution	64 k colors	
Contrast ratio (Normally)	normally: 300:1	
Brightness	Normally: 250 cd/m ²	
Backlight		
Technology	LED	
Dimmable with software	Yes: 100 - 1% brightness	Yes: 100 - 20% brightness
lifespan	normally: 40000 h	
Resistive touch protective screen	Touch sensor (glass with foil)	
Touch sensor		
Part no.	Resistive-Touch	
Technology	4 conductor	
System		
Processor	RISC, 32 bit, 400 MHz	
Internal memory		
DRAM	64 MByte	
NAND flash	64 MByte	
NVRAM	125 Kbyte	
NOR flash	–	2 MByte
External memory		
SD Memory Card Slot	1 x SDA Specification 1.00 suitable for SD cards (not for SDHC cards or cards of new standards) Only use original accessories!	
Real-time clock (battery back-up)		
Battery type	CR 2032 (220 mA/h), zero maintenance (soldered)	

4 Appendix

4.2 Technical data

Technical data	Value	Value
	NZM-XMC-MDISP35-...	NZM-XMC-MDISP70-...
Backup time at zero voltage	normally: 10 years	
Interfaces		
Ethernet	100Base-TX/10Base-T	
USB Device	USB 2.0, not galvanically isolated	
Interfaces/ports (depends on the enclosure version)		
USB Host	–	USB 2.0 (1.5 Mbit/s/12 Mbit/s/480 Mbit/s), not galvanically isolated
SmartWire-DT Master	SmartWire-DT, not galvanically isolated	
RS485	not galvanically isolated	galvanically isolated
DIAG	For servicing purposes only	
UPD/RUN jumper	For servicing purposes only	
Power supply		
rated operating voltage	24 V DC SELV (safety extra low voltage)	
Permissible voltage	Effective: 19.2 - 30.0 V DC (Rated operating voltage -20 %/+25 %) Absolute with ripple: 18.0 - 31.2 V DC Battery powered: 18.0 - 31.2 V DC (Rated operating voltage -25 %/+30 %) 35 V DC for a duration of < 100 ms 10 ms from rated operating voltage (24 V DC) 5 ms from undervoltage (20.4 V DC)	
Voltage dips	10 ms from rated operating voltage (24 V DC) 5 ms from undervoltage (20.4 V DC)	
Power consumption		
Basic device	max. 5 W	max. 7W
USB device on USB host	–	max. 2.5 W
Total	max. 5 W	max. 9.5W
Current consumption		
Continuous current	max. 0.2 A (24 V DC)	max. 0.4 A (24 V DC)
Starting current inrush	1.5 A ² s	
Protection against polarity reversal	yes	
fuse	yes (should only be replaced by the manufacturer or by an authorized repair center)	
Potential isolation	no	
SmartWire-DT Master		
Supply voltage U _{AUX} (control voltage for contactor coils)		
rated operating voltage	24 V DC	
Permissible voltage	effective: 20.4 - 28.8 V DC (Rated operating voltage -15 %/+20 %)	
Residual ripple of input voltage	max. 5 %	
Protection against polarity reversal	yes	

Technical data	Value	Value
	NZM-XMC-MDISP35-...	NZM-XMC-MDISP70-...
Current		
As per DIN VDE 0641, Part 11, IEC/EN 60898	max. 3 A	
As per UL 508 and CSA-22.2, No. 14	max. 2 A	
Short-circuit rating	None – external protection required (e.g., with FAZ Z3)	
Heat dissipation	Normally: 1 W	
Potential isolation	no	
Rated operating voltage of 24 V DC modules	Normally: $U_{AUX} - 0.2 V$	
Supply voltage U_{POW} (for SmartWire-DT modules)		
rated operating voltage	24 V DC	
Permissible voltage	RMS: 20.4 - 28.8 V DC (rated operating voltage -15%/+20%)	
Residual ripple of input voltage	max. 5 % max. 5 %	
Protection against polarity reversal	yes	
Current	max. 0.7 A	
Overload proof	yes yes	
Inrush current and length	12.5 A/6 ms	
Heat dissipation at 24 V DC	1.0 W	
Potential isolation between U_{POW} and 15 V SmartWire-DT supply voltage	no	
Bridging voltage dips	10 ms	
Repetition rate	1 s	
Status indication	Yes (with LEDs)	
SWD (SmartWire-DT interface)		
SmartWire-DT supply voltage U_{VP}		
Rated operating voltage (internally converted supply voltage U_{POW})	14.5 V DC $\pm 3\%$ (14.0 - 15.0 V DC)	
Current	Max. 0.7 A ¹⁾	
Short-circuit rating	yes	
SmartWire-DT module address setting	Automatic	
Baud Rate	125 kBit/s; 250 kBit/s	
Switches via SmartWire-DT	8	16

1) If SmartWire-DT modules with a total current consumption > 0.7 A are connected, a EU5C-SWD-PF2 power feeder module has to be used.

4.3 Dimensions

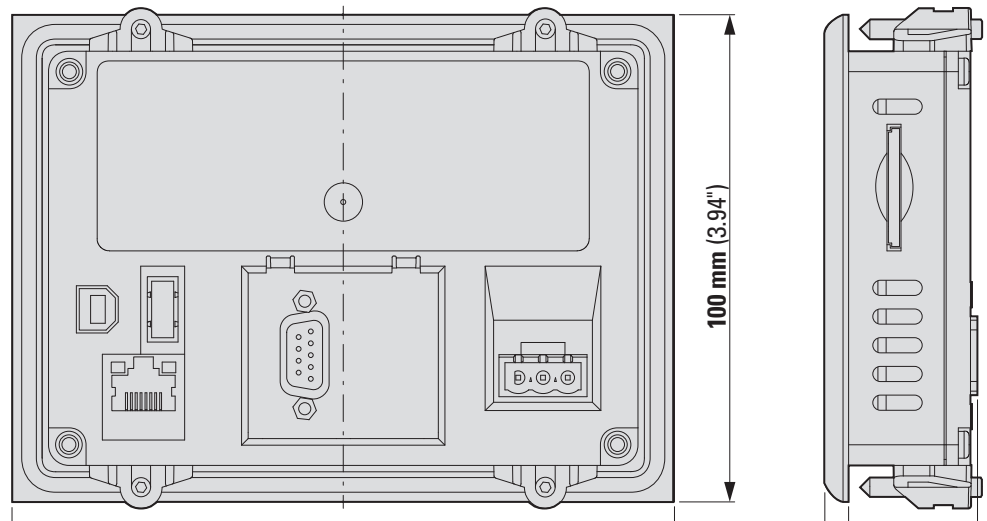

Figure 28: Dimensions NZM-XMC-MDISP35-...

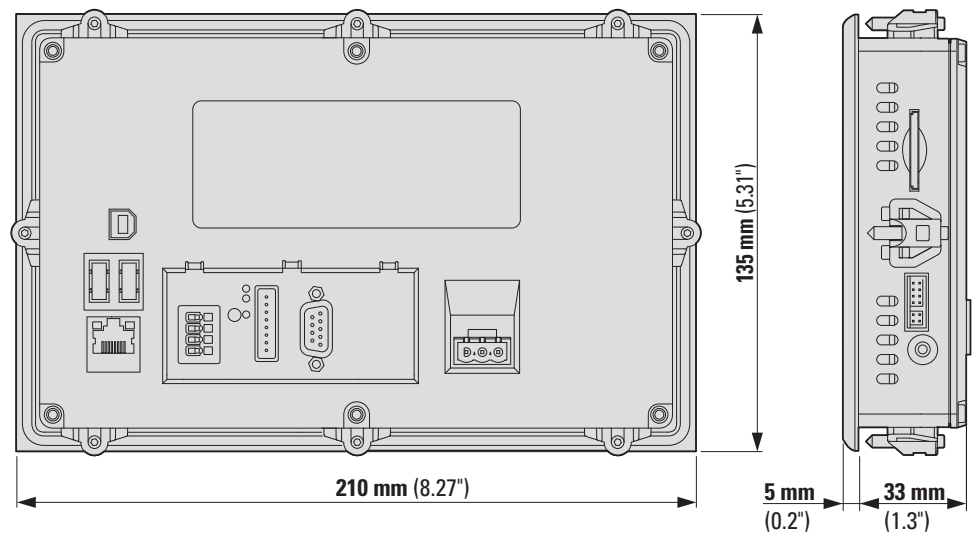

Figure 29: Dimensions NZM-XMC-MDISP70-...

Alphabetical index

A	
Ambient conditions	17
B	
Battery	14
Bus Termination	32
C	
Cable screen	22
Commissioning the SmartWire-DT	30
Communication Interfaces	8
configuration	31
D	
Description of device	7
Device models	8
Dimensions	44
Disposal	15
E	
Equipment supplied	13
Ethernet interface	26
H	
Hotline	15
I	
Installation	17
Installation cut-out	35
Installation position	18
Interferences	39
M	
Marine approvals	12
Mounting	34
N	
Nameplate	13
O	
Operation	37
P	
Package contents	9
Pictures showing the back of the devices ..	20, 21
Power supply	23
R	
Repair	14
Resistive touchscreen	
Cleaning	14
Recalibrating	14
RS485 interface	32
RS485-topology	33
S	
SD card	38
Service	15
SmartWire-DT master interface	27
Control and display elements	28
Storage	14
Stray currents	16
T	
Technical data	40
Topology	9
Torque	17
transport	15
Troubleshooting	39
U	
UL, requirements	17
USB host interface	27
V	
ventilation	18
W	
Warranty	15
wiring	22, 24, 29
Wiring diagram	10

Eaton is dedicated to ensuring that reliable, efficient and safe power is available when it's needed most. With unparalleled knowledge of electrical power management across industries, experts at Eaton deliver customized, integrated solutions to solve our customers' most critical challenges.

Our focus is on delivering the right solution for the application. But decision makers demand more than just innovative products. They turn to Eaton for an unwavering commitment to personal support that makes customer success a top priority. For more information, visit www.eaton.eu.

Eaton Adressen weltweit:
www.eaton.com/Worldwide Sites

E-Mail: info-bonn@eaton.com
Internet: www.eaton.eu/nzm

Eaton Industries GmbH
Hein-Moeller-Str. 7-11
D-53115 Bonn

© 2014 by Eaton Corporation
All rights reserved
MN048013 EN Doku/IAB 11/16



Powering Business Worldwide