

Definite Purpose Molded-Case Circuit Breakers

Contents

| Description | Page |
|--|------|
| Type GP 15–100A Three-Pole | 2 |
| Type GP 15–100A Three-Pole Cutout and Drilling Plan | 3 |
| Type FP 15–225A Three-Pole | 4 |
| Type FP 15–225A Three-Pole Cutout and Drilling Plan | 5 |
| Type KP 200–400A Three-Pole | 6 |
| Type KP 200–400A Three Pole Cutout and Drilling Plan | 7 |
| Type LP 450–600A Three-Pole | 8 |
| Type LP 450–600A Three-Pole Cutout and Drilling Plan | 9 |
| Type MP 700–800A Three-Pole | 10 |
| Type MP 700–800A Three-Pole Cutout and Drilling Plan | 10 |



Powering Business Worldwide

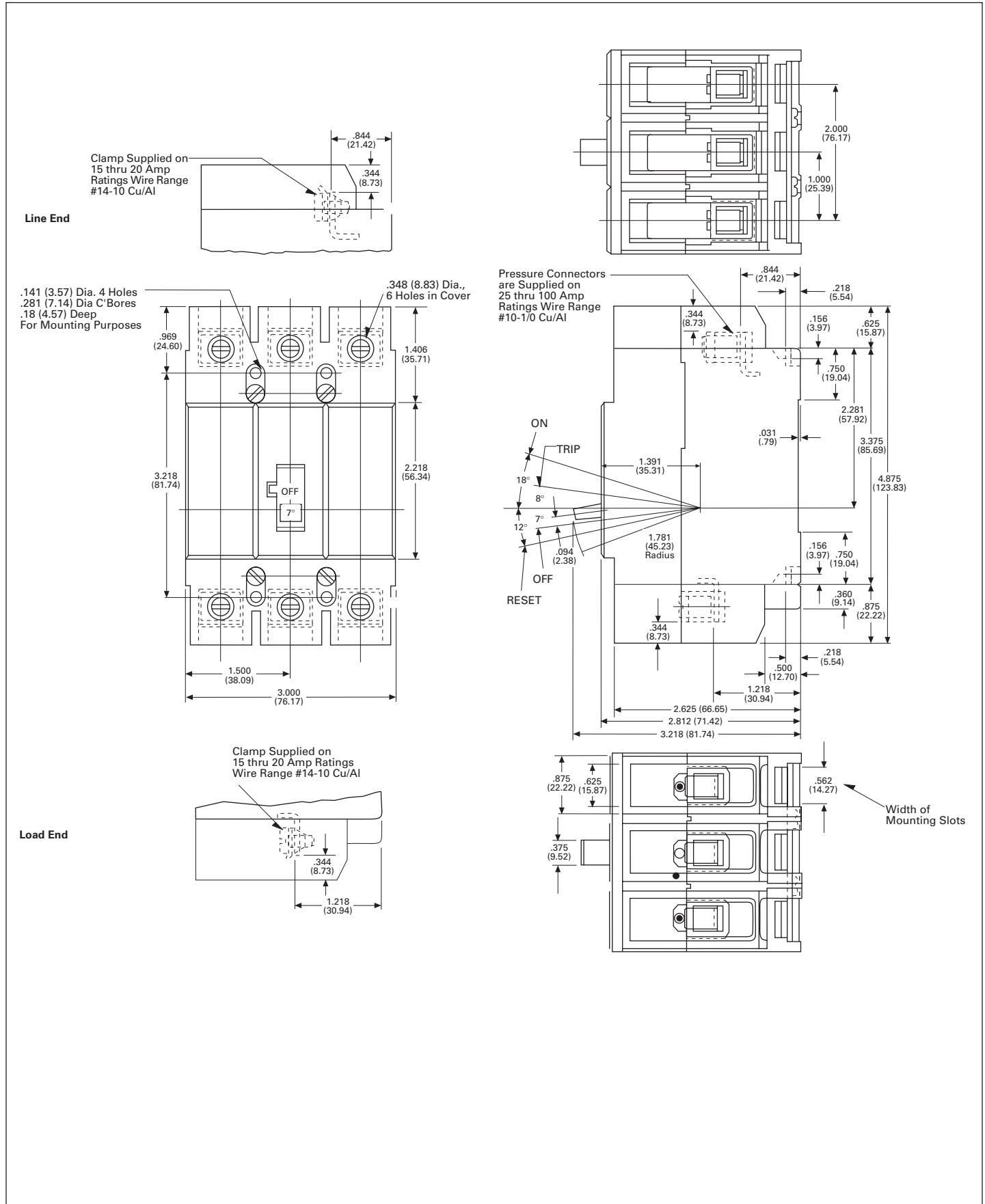

Figure 1. Type GP 15-100A Three-Pole—Dimensions in Inches (mm).

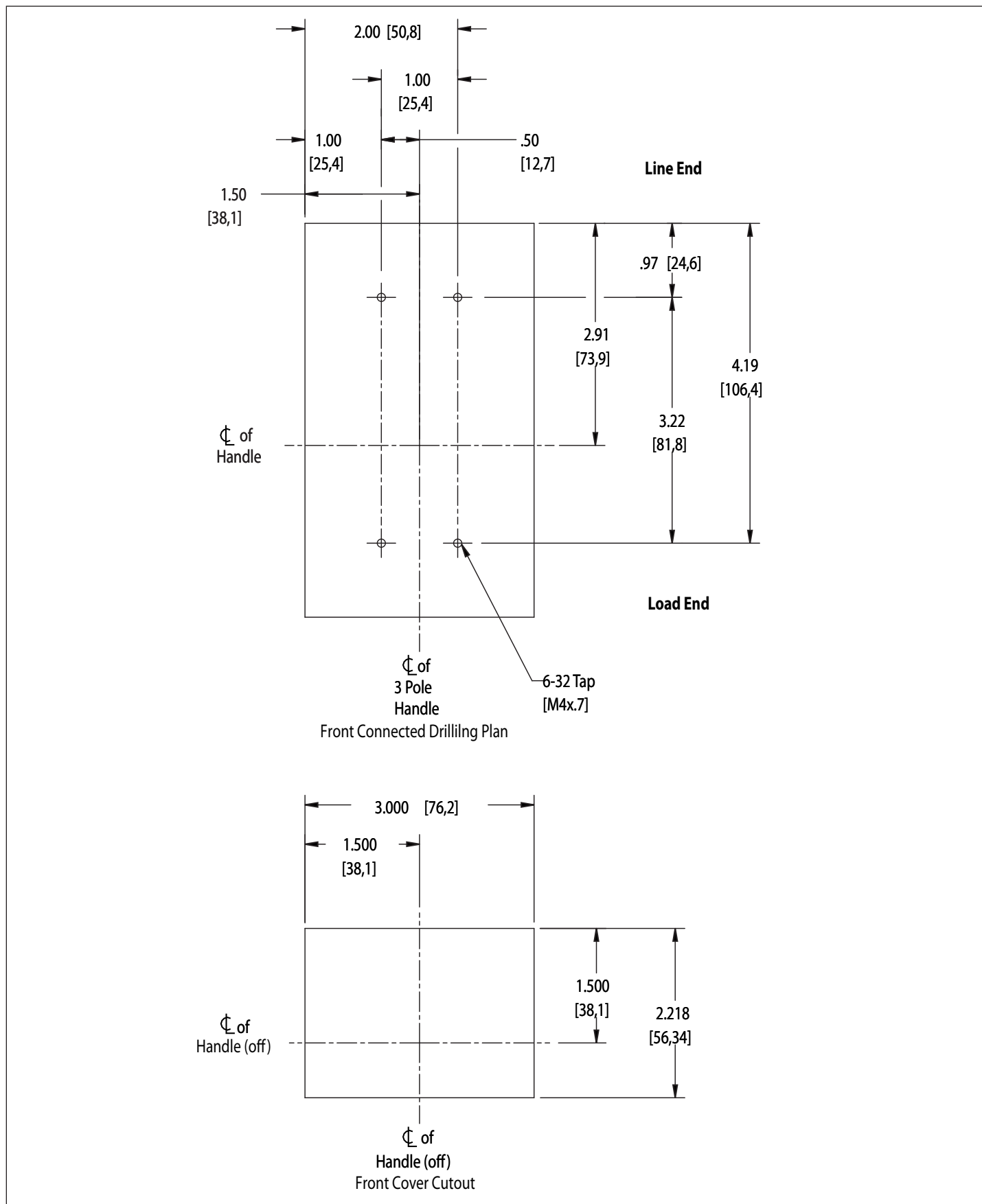

Figure 2. Type GP 15-100A Three Pole Cutout and Drilling Plan - Dimensions in Inches (mm).

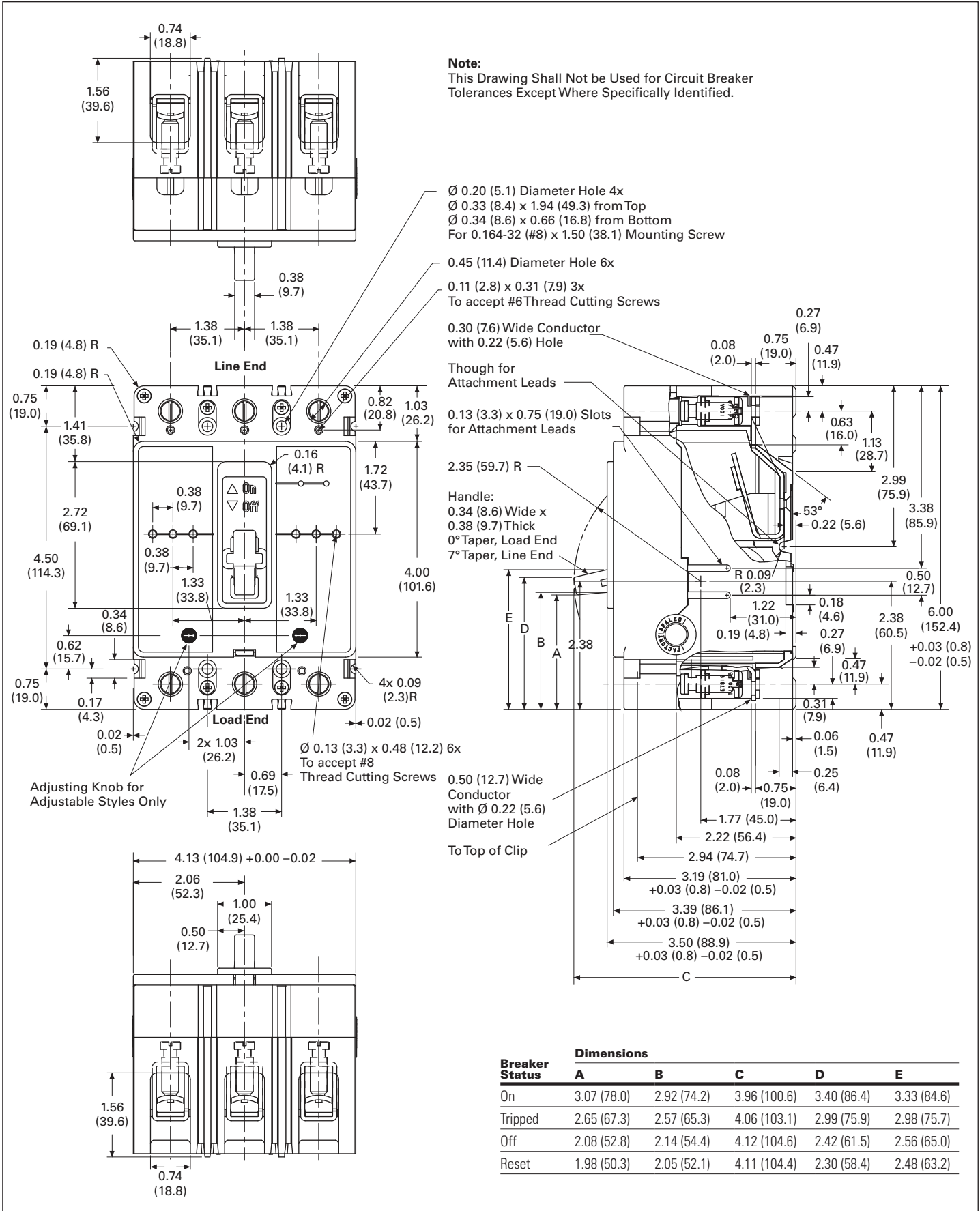

Figure 3. Type FP 15-225A Three-Pole—Dimensions in Inches (mm).

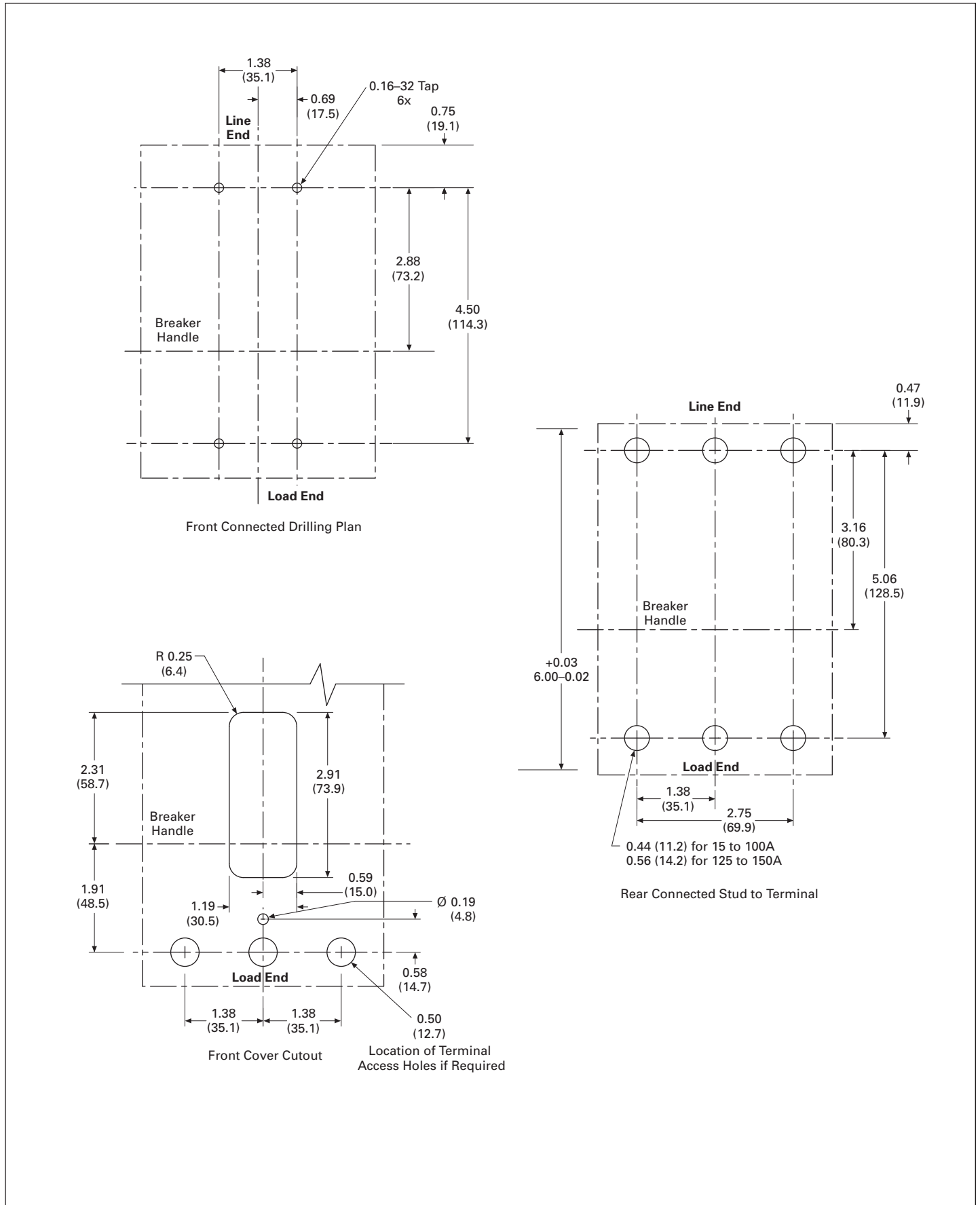

Figure 4. Type FP 15-225A Three-Pole Cutout and Drilling Plan—Dimensions in Inches (mm).

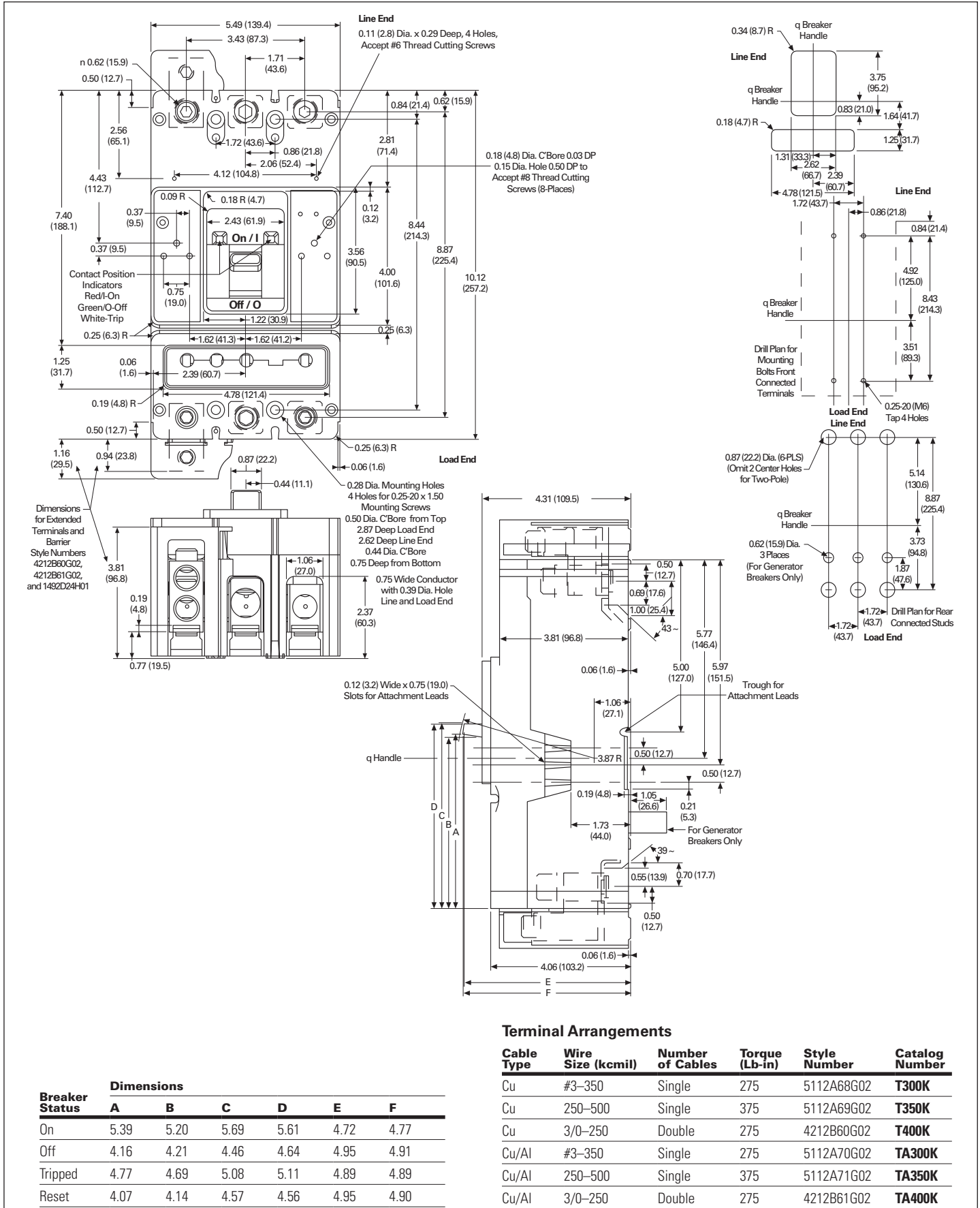

Figure 5. Type KP 200-400A Three-Pole—Dimensions in Inches (mm).

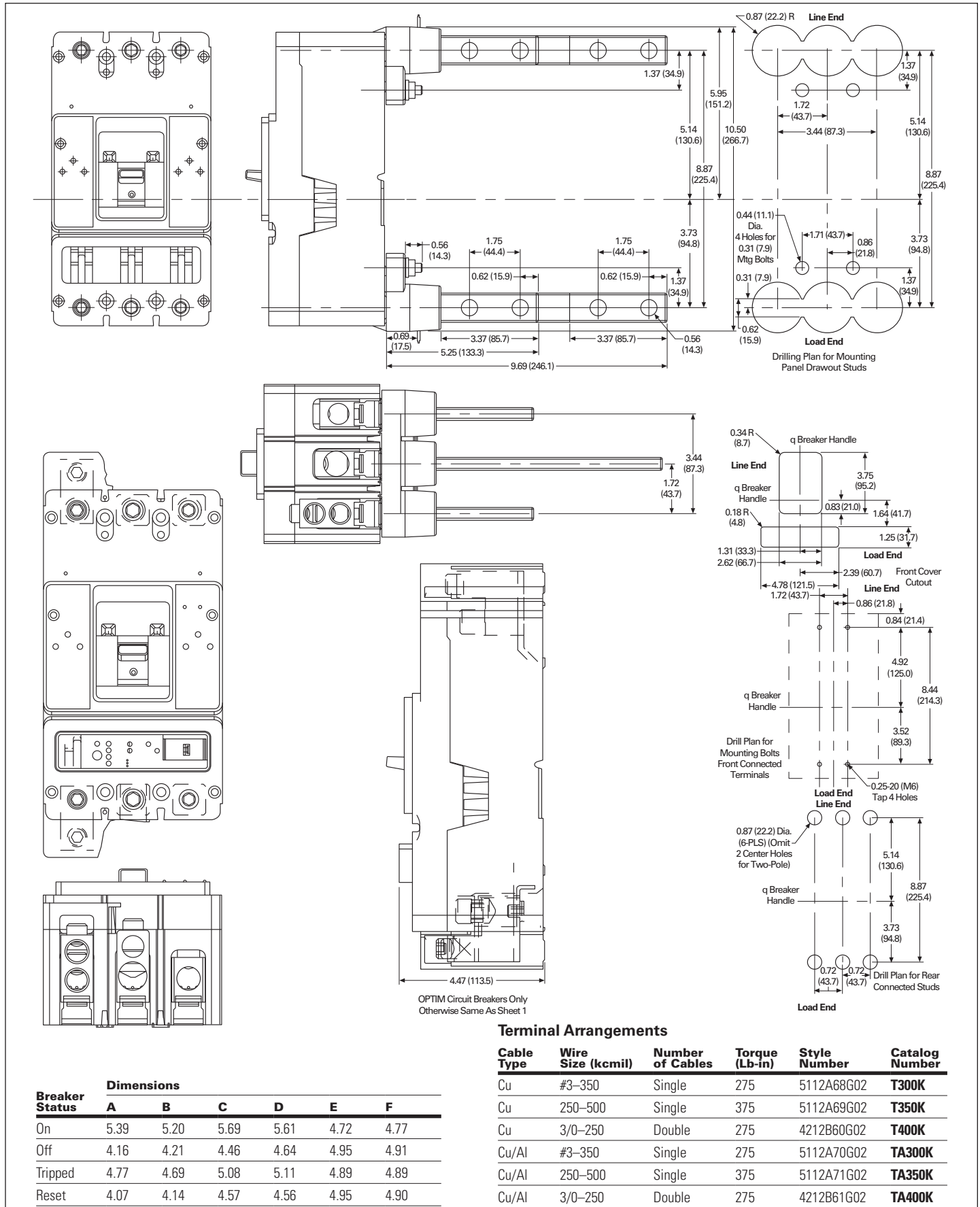

Figure 6. Type KP 200-400A Three Pole—Dimensions in Inches (mm).

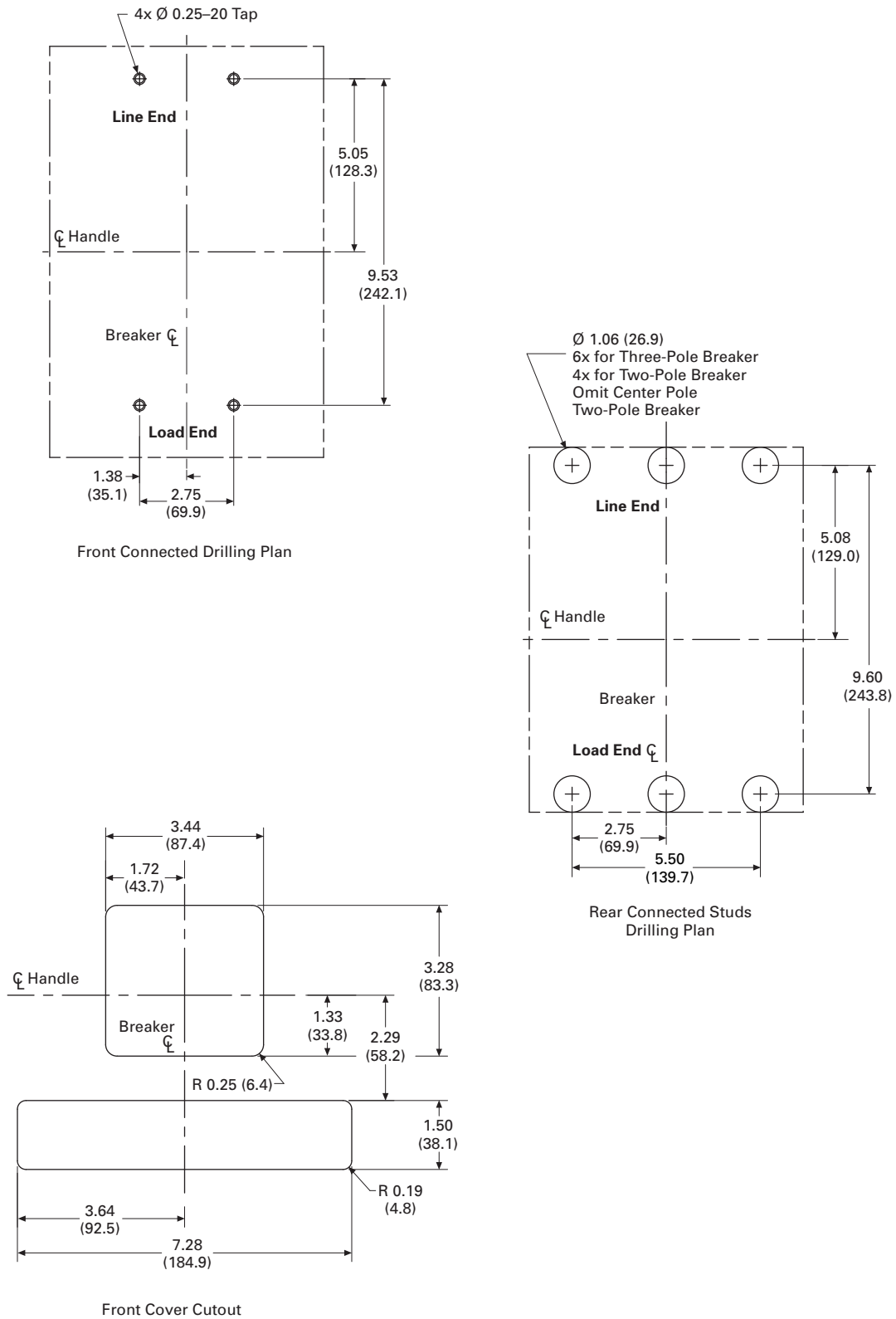

Figure 8. Type LP 450-600A Three-Pole Cutout and Drilling Plan—Dimensions in Inches (mm).

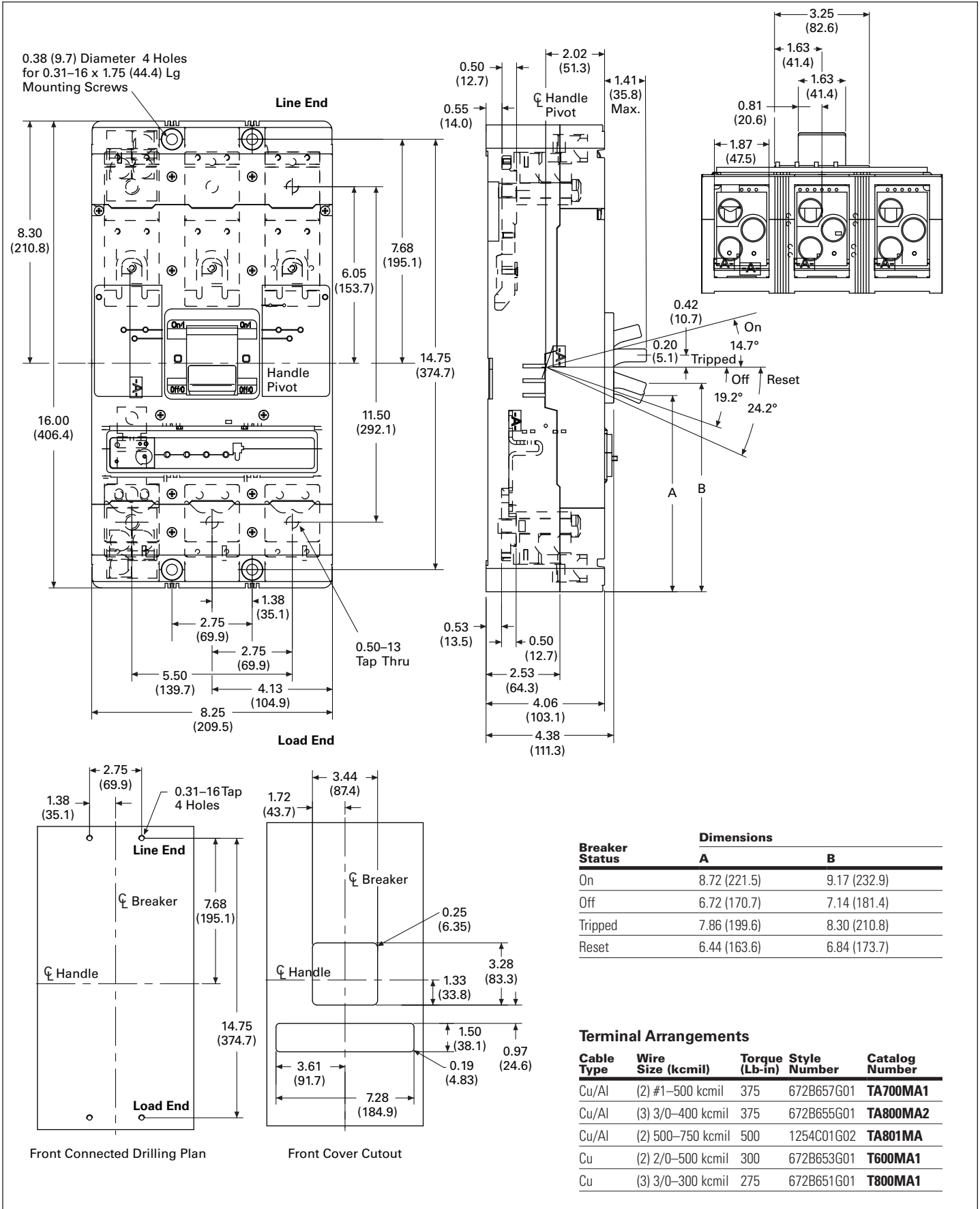

Figure 9. Type MP 700-800A Three-Pole Cutout and Drilling Plan—Dimensions in Inches (mm).

Notes:

Eaton Corporation
Electrical Sector
1111 Superior Ave.
Cleveland, OH 44114
United States
877-ETN-CARE (877-386-2273)
Eaton.com

© 2012 Eaton Corporation
All Rights Reserved
Printed in USA
Publication No. TD01208006E / TBG000879
March 2012



Eaton is a registered trademark of
Eaton Corporation.

All other trademarks are property of their
respective owners.