

MEDIUM VOLTAGE VACUUM CIRCUIT BREAKERS

Type VCP-W Vacuum Circuit Breakers
ANSI 5/15 kV at 1200-3000 Amperes
250-1500 MVA, 60-95 kV BIL
IEC 3.6/17.5 kV at 630-2000 Amperes
25-40 kA, 40-95 kV BIL

OEM SWITCHGEAR COMPONENT PRODUCTS

The leading value-added modular approach for assembling metal-clad switchgear featuring Cutler-Hammer medium voltage vacuum circuit breakers, structures and accessories.



EATON

Cutler-Hammer

Cutler-Hammer Products

The Industry Leader
in Vacuum Circuit Breakers

VacClad-W, the Cutler-Hammer vacuum switchgear family, has been engineered to feature a standardized design, interchangeable parts, slot and tab construction, and industry-leading vacuum interrupter technology. This world class switchgear includes the Type VCP-W Vacuum Circuit Breaker which meets both ANSI and IEC electrical standards.

Industry-Leading Vacuum Technology Provides Unequaled Reliability

Cutler-Hammer now provides the industry's most complete family of technologically advanced vacuum circuit breakers at 5 kV, 15 kV, 27 kV, and 38 kV. Type VCP-W Vacuum Circuit Breakers incorporate many design features which have been field proven with more than 25 years of vacuum interrupter design and manufacturing experience...coupled with over 70 years of power circuit breaker design and manufacturing experience.

Type VCP-W Vacuum Circuit Breakers are available in a complete range of ANSI and IEC ratings:

ANSI 5 kV through 38 kV,
continuous currents from
600 through 3000 amperes.

IEC 3.6 kV through 36 kV,
continuous currents from
630 through 2000 amperes.

ISO Certified Facilities

Type VCP-W Vacuum Circuit Breakers, including the vacuum interrupter, are assembled by Cutler-Hammer in ISO 9002 certified facilities. The breakers are fully tested to ANSI and IEC standards and each is provided with its unique Quality Assurance Certificate that documents all tests and inspections performed.

Assembly Flexibility

Assembly flexibility is provided with a variety of industry leading value-added approaches for assembling premier metal-clad switchgear. Customers have the unique opportunity to select the appropriate building block approach to match their manufacturing capabilities with those of Cutler-Hammer.

The OEM Value-Added Approach to Circuit Protection... Flexibility that Exceeds the Customer's Requirements



Type VCP-W Vacuum Circuit Breakers

*Industry Leading Vacuum Technology
in ANSI 5/15 kV or IEC 3.6/17.5 kV*

- Type VCP-W.
- Type VCPW-SE.
- Type VCPW-ND.



Power Modules

*Complete Structures
Including Fully Equipped Breaker
Compartment and Auxiliary Provisions*



Mini Modules

*A Simple Building Block Approach
Easily Configured to Any Project Specification*

Mini Modules Configured as:

- A One-High Fully Equipped Breaker Compartment for 1200, 2000, or 3000 Amperes.



Circuit Breaker Compartment Kits

*Provide the Opportunity to Add the Most
Value and Include All Key Breaker/Cell
Interfacing Parts Necessary to Build
a Breaker Compartment*



Auxiliary Drawer Compartment Kits

*All Parts Necessary for Building Potential
Transformer, Control Power Transformer,
or Fuse Drawer Compartments*



Tools and Accessories

*A Complete Selection of Standard
and Optional Tools and Accessories*

Cutler-Hammer 5/15 kV Medium Voltage Switchgear Components

5/15 kV Medium Voltage Breaker Rating Chart

ANSI Standards – Type VCP-W Vacuum Circuit Breaker Rated on Symmetrical Current Rating Basis^①

Identification			Rated Values												Weight
Circuit Breaker Type	Nominal Voltage Class	Nominal 3-Phase MVA Class	Voltage		Insulation Level		Continuous Current at 60 Hz	Short Circuit Current (at Rated Maximum kV)	Interrupting Time ^④	Permissible Tripping Delay	Maximum Voltage Divided by K	Current Values			Weight
			Maximum Voltage	Voltage Range Factor ^③	Withstand Test Voltage	Power Frequency (1 Minute)						Impulse	Maximum Symmetrical Interrupting Capability	Closing and Latching Capability	
			E	K	kV rms	kV Peak	Amperes	kA rms	Cycles	Seconds	kV rms	kA rms	kA Peak	kA rms	lbs.
50VCPW-ND250	4.16	250	4.76	1.24	19	60	1200	29	5	2	3.85	36	97	58	345
50VCP-W250	4.16	250	4.76	1.24	19	60	1200 2000 3000	29	5	2	3.85	36	97 132 ^②	58 78 ^②	350 410 525
50VCP-W350	4.16	350	4.76	1.19	19	60	1200 2000 3000	41	5	2	4.00	49	132	78	460 490 525
75VCP-W500	7.2	500	8.25	1.25	36	95	1200 2000 3000	33	5	2	6.60	41	111	66	375 410 525
150VCP-W500	13.8	500	15.00	1.30	36	95	1200 2000 3000	18	5	2	11.50	23	62 97 ^②	37 58 ^②	350 410 525
150VCP-W750	13.8	750	15.00	1.30	36	95	1200 2000 3000	28	5	2	11.50	36	97 130 ^②	58 77 ^②	350 410 525
150VCP-W1000	13.8	1000	15.00	1.30	36	95	1200 2000 3000	37	5	2	11.50	48	130	77	460 490 525
150VCP-W1500	13.8	1500	15.00	1.00	36	95	1200 2000 3000	63	5	2	15.00	63	170	101	525 530 550

IEC-56 Standards – Type VCP-W Vacuum Circuit Breaker Rated on Symmetrical Current Rating Basis^⑥

Identification		Rated Values							Weight
Circuit Breaker Type	Voltage Class	Insulation Level		Normal Current	Short Circuit Breaking Current	Short Time (3 Second) Current	Short Circuit Making Current	Cable Charging Breaking Current	Weight
		Power Frequency	Impulse Withstand						
		kV rms	kV Peak	kV Peak	Amperes	kA rms	kA rms	kA Peak	Amperes
36VCPW-ND25	3.6	10	40	630, 1250	25	25	63	25	159
36VCPW-ND32	3.6	10	40	630, 1250	31.5	31.5	79	25	159
72VCPW-ND25	7.2	20	60	630, 1250	25	25	63	25	159
72VCPW-ND32	7.2	20	60	630, 1250	31.5	31.5	79	25	159
36VCP-W25	3.6	10	40	630, 1250, 2000	25	25	63	25	188
36VCP-W32	3.6	10	40	1250, 2000	31.5	31.5	79	25	188
36VCP-W40	3.6	10	40	1250, 2000	40	40	100	25	225
72VCP-W25	7.2	20	60	630, 1250, 2000	25	25	63	25	188
72VCP-W32	7.2	20	60	1250, 2000	31.5	31.5	79	25	188
72VCP-W40	7.2	20	60	1250, 2000	40	40	100	25	225
120VCP-W25	12	28	75	630, 1250, 2000	25	25	63	25	195
120VCP-W32	12	28	75	1250, 2000	31.5	31.5	79	25	195
120VCP-W40	12	28	75	1250, 2000	40	40	100	25	225
175VCP-W25	17.5	38	95	1250, 2000	25	25	63	31.5	195
175VCP-W32	17.5	38	95	1250, 2000	31.5	31.5	79	31.5	195
175VCP-W40	17.5	38	95	1250, 2000	40	40	100	31.5	225

① Applicable ANSI standards C37.04 - 1979, C37.09 - 1979, and C37.06 - 1987. Operating duty cycle CO-15 seconds-CO. Operating time values: opening 30-45 ms, closing 45-60 ms and reclosing 18 cycles (300 ms).

② Nonstandard circuit breakers with High Close and Latch (momentary) rating for special applications.

③ Consult Application Data 32-265 for further information.

④ Optional interrupting time of 3 cycles is available.

⑤ Also 3 second short time current carrying capability.

⑥ Interrupting time is 3 cycles at 50/60 Hz. Rated operating sequence: O-3 minutes-CO-3 minutes-CO.

Cutler-Hammer Products

Metering, Protection, and Communications

Cutler-Hammer Power Management Products provide the solutions to monitor and manage all aspects of an electrical distribution system. These innovative meters, relays and communications software applications make it possible to realize greater reliability, increased productivity and significant cost savings.

METERS

IQ Analyzer 6400/6600 Series

The Premier Power Quality Meter

The IQ Analyzer provides comprehensive diagnostic capabilities with over 150 metered values. This device assists in preventing process disruptions and equipment damage by storing trends, analyzing harmonics and capturing waveforms. Historical data captured by the IQ Analyzer helps to identify problems in an electrical distribution system. Energy usage and costs are controllable through highly accurate energy measurement, on-board energy value storage and time-of-use energy registers. Optional graphical waveform and harmonic spectrum display available on the 6600 series.



IQ DP-4000

Metering and Voltage Protection

The IQ DP-4000 provides complete electrical metering and system voltage protection. This device measures and displays over 74 electrical system values. It measures % total harmonic distortion (%THD) for both current and voltage to help find the source of problems. The IQ DP-4000 keeps track of total energy used along with the maximum demand to aid in energy management. Optional digital I/O available on the 4100 series.



IQ 200

Switchboard Metering

The IQ 200 family is a group of revenue accurate ANSI C12.16 meters that provide big features in a small and flexible package. They are ideal for panelboard and switchboard applications where panel space is at a premium. Energy management information is provided by direct reading of metered values. With built-in communications the IQ 200 base can be used as a metering transducer for submetering applications.



PROTECTIVE RELAYS

MP-3000

Award-Winning Motor Protection

The MP-3000, winner of a Plant Engineering magazine Product of the Year award, protects three-phase induction motors of any size and voltage. Integral Intel-I-Trip™ overload protection develops protection curves based on motor data and adaptive characteristics based on measured RTD temperatures. The MP-3000 records motor history and time-stamped event logging in nonvolatile memory. This device is available in a quick-release drawout case model.



FP-5000

Integrated Protection, Metering and Control for Electric Power Distribution

The FP-5000 provides advanced protection for mains, tiers and feeder circuits of any voltage level. This device provides complete three-phase and ground protection, time overcurrent protection with 11 user-selectable characteristic curve shapes, three custom curves, over and under voltage and frequency protection, phase sequence voltage protection, current unbalance protection and breaker failure protection. It provides complete metering and advanced data logging capabilities. The FP-5000 is available in a quick-release drawout case model.



Digitrip 3000

Increased Protection for Medium Voltage Circuit Breakers

The Digitrip 3000 provides three-phase and ground overcurrent instantaneous protection in a single, cost-effective package. It also provides current and monitoring capability. Optional zone selective interlocking is an alternative to high bus cost differential protection. The selectable long time curve slope (ANSI: Moderately inverse, very inverse, and extremely inverse and thermal curves: It, T²t, T³t, flat) provides protection for a wide range of protection capability in a single device.



COMMUNICATIONS

PowerNet

Flexible Power Management System

PowerNet software is designed to manage the power distribution system. It's ideal for managing energy usage and costs, troubleshooting power quality problems and ensuring the reliability and integrity of the electrical distribution system. A PowerNet Power Management System consists of PowerNet software networked with meters, relays, trip units, motor protectors, starters and transfer switch controllers. PowerNet has an extensive library of third-party interfaces, facilitating integration with other manufacturers' devices and building management systems.

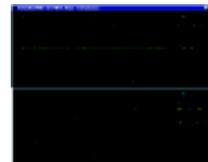

PowerPort

Single Device Monitoring and Configuration Software

PowerPort is free software downloadable from <http://www.ch.cutlerhammer.com/pmp/PowerPort.html>. It is a scaled-down version of Power Net. PowerPort simplifies the setup and configuration of select Cutler-Hammer devices, including the IQ Analyzer, MP-3000 and FP-5000, by enabling the user to enter the device setpoints via a user-friendly PC interface. Then the information can be downloaded to the device, eliminating the need to scroll through the device menu at the faceplate. A single device can be monitored via PowerPort.

GENESIS32™

Web-Based HMI Software

GENESIS32 is Cutler-Hammer's graphical solution and includes GraphWorx, TrendWorx, AlarmWorx and Web HMI software. The basic bundle also includes an integrators tool of Modbus to OPC to facilitate the communications with Modbus devices in your network. These applications provide customized graphical displays, ease of integration and portability of data throughout the enterprise network, even via a web browser thin client. This bundle provides the flexible and powerful graphic applications that are easily deployed.

GENESIS32 is a trademark of ICONICS.

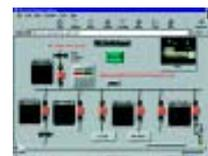

ACCESSORIES

EZC Minalites®



Compact indicating lights for general indicating or signaling. They are quickly and easily mounted on panels up to and including 1/4 inch in thickness. Round and rectangular designs are available.

Industry Leading Vacuum Technology Enhances Breaker and Switchgear Reliability

Type VCP-W Vacuum Circuit Breakers

The highly dependable performance of Cutler-Hammer vacuum circuit breakers results from our commitment to a continuing research and development program.

Beginning with early research in 1929, we have been a leader in the vacuum interrupter field. Production was launched in the mid-1960s, and since that time hundreds of thousands of vacuum interrupters have been in reliable operation worldwide.

Cutler-Hammer experience has resulted in many significant vacuum interrupter breakthroughs including:

- Copper chrome contact materials that provide longer life.
- A smaller envelope size with higher performance.
- Lower chop currents.
- Improved dielectric strength.

Consequently, Cutler-Hammer vacuum interrupters are maintenance free...and provide increased service life and optimum operator safety.

Type VCP-W Vacuum Circuit Breakers Are Designed with the Patented V-Flex Nonsliding, Nonrolling Current Transfer System

The current transfer system consists of a series of tin-plated, high-conductivity copper leaf conductors that are swaged onto the movable interrupter stem.



World-class VCP-W Vacuum Circuit Breakers designed with a patented V-Flex nonsliding current transfer system.



Unique swaged design benefits include:

- Improved current flow because the multipoint contact offers very low electrical and thermal resistance.
- Unlike sliding or rolling designs, there are no moving parts to wear out...therefore, no maintenance.
- Longer circuit breaker service life.

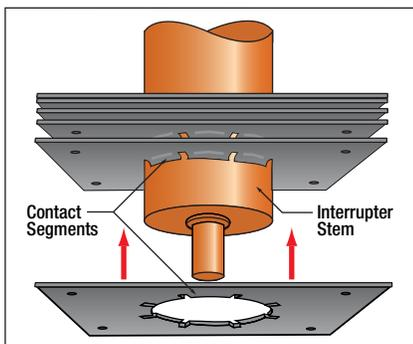

Nonsliding Current Transfer System

Connecting each leaf conductor to the vacuum interrupter stem initiates a flattening operation of the segments which are, in turn, swaged into contact with the stem. Each leaf, therefore, provides a multipoint connection. As the stem moves up and down, the V-Flex system flexes, eliminating the sliding action to provide a minimal wear and maintenance-free system.

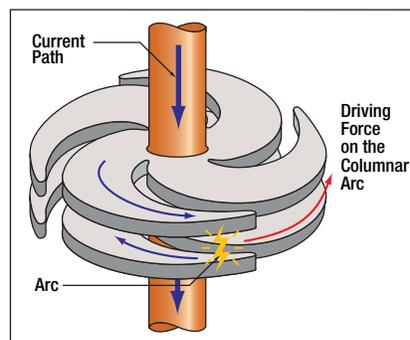

Arcing and Interruption in Vacuum

Inside the vacuum bottle, the spiral contact design configuration provides a self-induced magnetic effect that moves the arc root around the contact periphery. This type of arc control prevents hot spot formations and minimizes electrode erosion. The low resistance of the spiral design results in less heat to dissipate, providing the smallest possible envelope size.

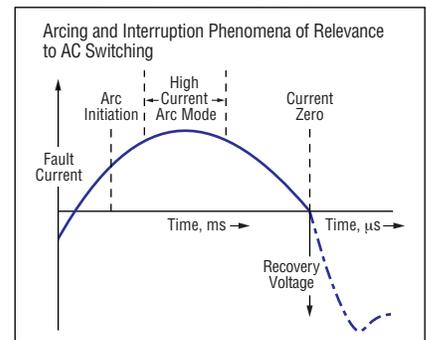

Arcing and Interruption Phenomena of Relevance to AC Switching

The important arcing and interruption phenomena that occur during fault current interruption in a vacuum are depicted above. These phenomena influence the design of the interrupter, particularly its size, configuration, and material of the contacts. Full dielectric strength is re-established to withstand transient recovery voltage (TRV) within a few microseconds, the fastest available.

Cutler-Hammer Products

Type VCP-W Vacuum Circuit Breaker... A New Level of Standardization

All Type VCP-W Vacuum Circuit Breakers, regardless of voltage or interrupting capacity, have the same time proven stored energy mechanism...and are significantly smaller than conventional medium voltage drawout breakers in *both* size and weight. Refer to weights table on page 11.

Three Methods of Easy Installation

Lower Compartment Installation

1. A roll off the floor ramp.
2. A dockable dolly.

The floor ramp or dockable dolly is used for quick lower cell installation or removal.

Upper and Lower Compartment Installation

3. A lifting yoke that is compatible with any standard lifting device.

Since the breaker rides on extension rails, alignment problems are eliminated and installation time is reduced. Additionally, a position indicator shows when the breaker is in the fully connected or disconnected position.

Designed for Operator Safety

Two dead front shields are provided to isolate the operator from high voltage when the breaker is energized.

During levering, safety interlocks render the breaker mechanically trip free and the breaker is grounded throughout its travel. The "T" handle latch which engages and disengages the breaker is at the bottom of the breaker, far from energized parts.

When the breaker is withdrawn, steel shutters automatically rotate to cover the primary disconnect supports...and a current transformer barrier is located in front of the shutters. This prevents the operator from accidental contact with primary voltage parts and controls.



VCP-W Vacuum Circuit Breaker Compartment

- 1 Metal shutters
- 2 Ground stab assembly
- 3 Breaker position indicator
- 4 Levering mechanism
- 5 MOC/TOC switch location
- 6 Drawout type secondaries



VCP-W Vacuum Circuit Breaker

- 7 Vacuum interrupter
- 8 Patented V-Flex nonsliding, non-rolling current transfer system
- 9 Direct reading contact erosion indicator
- 10 Breaker wheels
- 11 Removable glass polyester insulating barriers



- 12 Front panel controls and indicators
- 13 Removable dead front cover
- 14 "T" handle latch
- 15 Drawout type secondaries

Cutler-Hammer 5/15 kV Medium Voltage Switchgear Components

Tools and Accessories

Cutler-Hammer provides several standard and optional accessories including equipment used to transport the breaker and lift and lever it into a compartment, as well as a manually operated ground and test device.

The optional portable lifter is used to lift the breaker from or onto the extension rails.



Optional accessories include (clockwise): lifting yoke, test cabinet, spin-free levering crank, and test jumper.



Standard accessories include (top to bottom): manual charging handle, left and right removable extension rails, rail clamps, and levering crank.

A dockable dolly for transporting the lower breaker to or from the lower compartment.

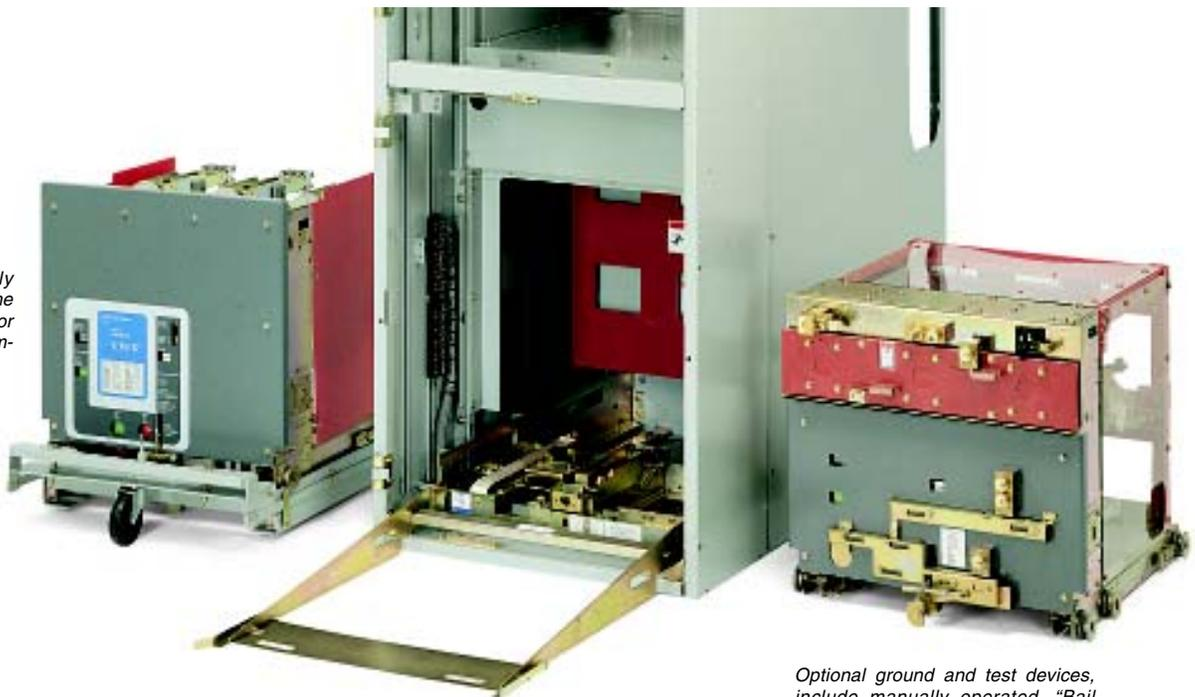

A roll off the floor ramp is used to move the lower breaker from the floor to the bottom compartment.

Optional ground and test devices, include manually operated, "Bail Type" manually operated, electrically operated, and "Consolidated Edison" user type (shown). Dummy elements are also available.

Cutler-Hammer Products

Auxiliary Drawer Compartment Kits for Power Modules, Mini Modules, or Breaker Compartment Kit Value Added Approaches

These kits include all major parts used in assembling an auxiliary compartment. Each kit is shipped in a single carton with detailed instructions and drawings that include important dimensions, clearances and configurations. Power Module B-Planes are prepunched to accommodate any auxiliary compartment kit.

Potential Transformer Drawer Kit



 UL Recognized

Parts include:

- Left and right drawout rails.
- PT truck assembly. (Potential transformers and fuse mountings are not included.)
- Primary and secondary contact assemblies, standoff insulators, and cable supports.
- Shutter assembly.
- Hardware for cell mountings and alignment brackets.
- Horizontal sectioning barriers.
- Drawings are provided for manufacturing the back sheet. They also detail the clearances and locations of integral parts.
- Detailed assembly instructions.
- Available for 36 inch wide standard and 26 inch wide narrow design switch-gear configurations.



Control Power Transformer Drawer Kit

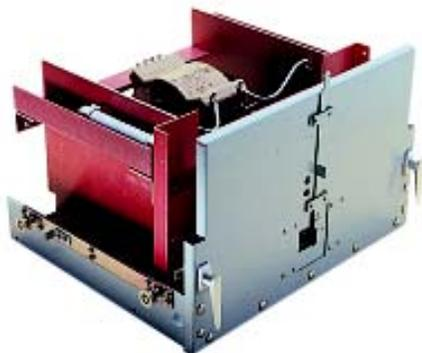

 UL Recognized

Parts include:

- Left and right drawout rails.
- CPT truck assembly including glass polyester barriers and secondary fuse mountings. (Control power transformers are not included.)
- Primary and secondary contact assemblies.
- Shutter assembly, standoff insulators, and cable supports.
- Hardware for all configurations and alignments including mounting and alignment brackets.
- Horizontal sectioning barriers.
- Drawings are provided for manufacturing the back sheet. They also detail the clearances and locations of integral parts.
- Detailed assembly instructions.
- Available for 36 inch wide standard and 26 inch wide narrow design switch-gear configurations.



Fuse Drawer Kit



 UL Recognized

Parts include:

- Left and right drawout rails.
- Fuse truck assembly including fuse holder assembly and various fuse mountings. (Fuses are not included.)
- Primary contact assemblies.
- Shutter assembly, standoff insulators, and cable supports.
- Hardware for all configurations and alignments including mounting and alignment brackets.
- Horizontal sectioning barriers.
- Drawings are provided for manufacturing the back sheet. They also detail the clearances and locations of integral parts.
- Detailed assembly instructions.
- Available for 36 inch wide standard and 26 inch wide narrow design switch-gear configurations.



Cutler-Hammer Vacuum Circuit Breakers Are Convenient to Operate, Simple to Inspect, and Easy to Maintain

User-Friendly Operation

Type VCP-W Vacuum Circuit Breaker controls and indicators are functionally grouped on the front control panel and include: contact position indicator, closing spring status, close and trip button, operation counter, and a breaker "T" handle latch (located at the bottom of the control panel).

The simplified design includes just five major components: vacuum interrupter pole units, stored energy mechanism, push rod assembly, primary disconnecting contacts, and removable glass polyester insulating barriers.

Convenient Inspection

The breaker is withdrawn on removable extension rails and no separate lifting device is required. There is no need to remove the breaker from the switchgear. With the breaker withdrawn, both the compartment and contact erosion indicator, and "T" cutout loading spring indicator can be visually inspected.

Both stored energy mechanism and control components are conveniently located behind the easily removed front panel. The current transformer barrier is easily removed for inspection and access to the current transformers. Auxiliary drawers use extension rails to provide for easy inspection and fuse replacement.

Easy Maintenance

Type VCP-W Vacuum Circuit Breakers are easily maintained. The easy access mechanism and control components can be conveniently inspected and minor maintenance (such as lubricating the mechanism and replacing control components) is uncomplicated.

A Standardized Line

Type VCP-W Vacuum Circuit Breakers represent a standard line that utilizes common parts. Standardization provides for fewer total parts which, in turn, reduces and simplifies the spare parts inventory. Type VCP-W Vacuum Circuit Breakers of the same ratings are totally interchangeable between structures.

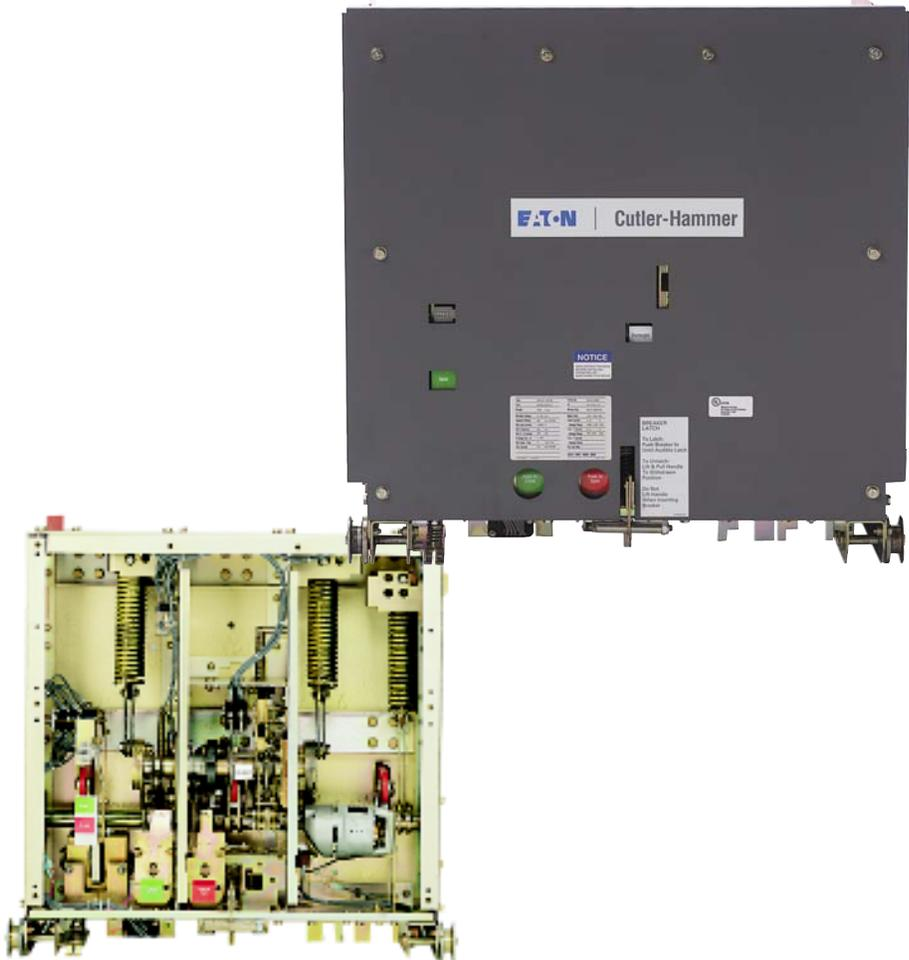

Stored energy mechanism is conveniently located behind the removable front panel. The front mounting of the mechanism provides two dead front shields between the operator and high voltage when the circuit breaker is energized.

Simplified Maintenance through Visual Inspection of Indicators

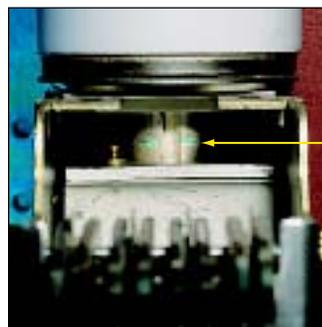

Contact Erosion Indicator

Easy-to-See Contact Erosion Indicator

The vacuum interrupter direct reading contact erosion indicator is clearly visible. Only periodic inspection of the erosion indicator is required.

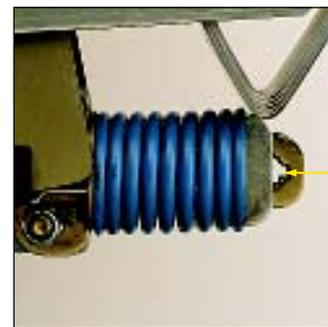

"T" Cutout Indicator

Convenient Loading Spring Indicator

Visual inspection of the "T" cutout loading spring indicator insures that when closing the breaker, the loading springs are applying proper pressure to the contacts.

Cutler-Hammer Products

No More than You Want...
No Less than You Need

A Modular Value-Added Approach to Circuit Protection...Exclusively from Cutler-Hammer

	26-Inch Narrow Design	36-Inch Standard Design
<p>5/15 kV Power Modules</p> <p><i>Provide OEMs with a Complete Structure</i></p>  		
<p>5/15 kV Mini Modules</p> <p><i>Provide OEMs with a More Value-Added Approach</i></p>  		
<p>5/15 kV Circuit Breaker Compartment Kits</p> <p><i>Provide OEMs with the Opportunity to Add the Most Value</i></p>  		
<p>5/15 kV Vacuum Circuit Breakers</p> 		

 UL Recognized

 UL Recognized

 UL Recognized

 Listed option is available

Type VCPW-ND

Type VCP-W / VCP-WC

Type VCP-WG

Type VCPW-SE

Power modules are ideal for OEMs who supply standard through complex switchgear. The OEM provides value-added items such as doors, bus, cable area compartments, instruments, relays and associated wiring. The power module incorporates individual vertical sections which will enclose a maximum of two Type VCP-W Circuit Breakers or four auxiliary drawers or a combination of one Type VCP-W Circuit Breaker and two auxiliary drawers.

- A complete structure including fully equipped circuit breaker and blank auxiliary compartment, control compartment, and main bus compartment...plus side and back sheets, roof assembly, door hinges/stops, and ventilation chimney.
- 36 inch wide design available in 10 configurations.
- 26 inch wide narrow design available in four configurations.

- The breaker can be inserted in the upper or lower compartment.
- Two auxiliary drawers (for PTs, CPT, or fuses) can be located in the upper or lower blank auxiliary compartment.
- Auxiliary compartment kits can be easily installed into any blank auxiliary power module compartment to suit any PT, CPT, or fuse drawer.
- All blank auxiliary B-Planes are prepunched to accept a PT, CPT, or fuse drawer kit.
- Exclusive 3,000 ampere breaker in the upper compartment with a single auxiliary drawer in the lower compartment.
- 4000 ampere forced air cooled power modules are also available.
- Available with glass polyester or porcelain insulating tubes for either 41 kA, 50 kA, or 63 kA applications.

Power Module Ampere Ratings

26" Narrow Design	1200A
36" Standard Design	1200A, 2000A, 3000A

Available Configurations

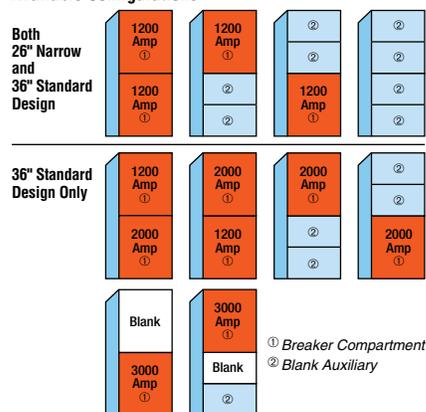

A simple building block approach in which the OEM provides value-added items such as doors, bus, cable area compartment, side sheets, instruments, relays, and associated wiring. Easily configured to suit many applications. Mini modules are available as:

- 1200, 2000, or 3000 ampere breaker compartment designs.

- Different bus terminal configurations available for upper or lower compartments.
- Boxed frame, levering-in assembly, glass polyester or porcelain insulating tubes for either 41 kA, 50 kA, or 63 kA applications, current transformer barrier, and shutter assembly.

Mini Module Ampere Ratings

26" Narrow Design	1200A
36" Standard Design	1200A, 2000A, 3000A

Circuit breaker compartment kits provide a maximum value-added approach to building switchgear, combining maximum design flexibility with cost competitiveness. Each circuit breaker compartment kit includes:

- Slot and tab design that assures all critical breaker/structure interfaces are maintained, eliminating the potential distortion problems that can occur with conventional weld/bend designs.
- Breaker levering-in assembly with left and right drawer drawout rails.

- Primary disconnect supports (upper and lower).
- Current transformer barrier assembly.
- Shutter assembly.
- Glass polyester or porcelain insulating tubes for either 41 kA, 50 kA, or 63 kA applications.
- Drawings that include dimensions and clearances are provided. B-Plane sheets are provided by the OEM to maximize a staged production process.

Compartment Kit Specifications

Ampere Rating	Primary Disconnect Supports	Stab Arrangements
26" Narrow Design		
1200A	Glass Polyester	Line and Load
36" Standard Design		
1200A	Glass Polyester or Porcelain	Line and Load or Line/Line Line and Load or Line/Line
2000A	Glass Polyester or Porcelain	Line and Load or Line/Line Line and Load or Line/Line
3000A	Glass Polyester or Porcelain	Line and Load Line and Load

Type VCPW-ND Medium Voltage Vacuum Circuit Breaker

The Type VCPW-ND Circuit Breaker offers proven industry leading vacuum circuit breaker technology in a 26 inch wide switchgear design, making it ideal for use when the benefits of a vacuum breaker are required and installation space is limited. The breaker is ANSI rated at 5 kV and IEC rated at 3.6/7.2 kV.*

Type VCP-W / VCP-WC / VCP-WG Medium Voltage Vacuum Circuit Breaker

As with all Cutler-Hammer vacuum circuit breakers, reliability of the standard design Type VCP-W Vacuum Circuit Breaker has been proven by over 25 years of vacuum circuit breaker design and manufacturing experience. The breaker is designed for 36 inch wide switchgear and is ANSI rated at 5/15 kV and IEC rated at 3.6/17.5 kV.*

Type VCPW-SE Medium Voltage Vacuum Circuit Breaker

The Type VCPW-SE Vacuum Circuit Breaker is designed for 36 inch wide switchgear applications and includes cycloaliphatic epoxy insulation and cross linked polyolefin insulated control wire, making it ideal for use in harsh industrial environments. The breaker is ANSI rated at 5/15 kV, and IEC rated at 3.6/17.5 kV.*

* Refer to page 11 for specific breaker ratings. UL listing, 3-cycle ratings, undervoltage release, and second shunt trip are optionally available.

**The World's Most Complete
Line of Medium Voltage
Vacuum Circuit Breakers**



Breaker Type	Voltage Class	Insulation BIL	Interrupting Ratings	Continuous Current	Application
VCPW-ND	ANSI 5 kV	60 kV	250 MVA	1200A	26" Wide New Metal-Clad Switchgear or Upgrades to Existing Airbreak Switchgear
	IEC 3.6-7.2 kV	40-60 kV	25-31.5 kA	630-1250A	
VCP-W	ANSI 5-15 kV	60-95 kV	250-1500 MVA	1200-3000A	36" Wide New Metal-Clad Switchgear or Upgrades to Existing Switchgear
	IEC 3.6-17.5 kV	40-95 kV	25-40 kA	630-2000A	
VCPW-SE	ANSI 5-15 kV	60-95 kV	250-1500 MVA	1200-3000A	36" Wide Special Environment Metal-Clad Switchgear Featuring Breakers with Cycloaliphatic Epoxy Insulation for Harsh Industrial Environments
	IEC 3.6-17.5 kV	40-95 kV	25-40 kA	630-2000A	
VCP-W	ANSI 27 kV	125 kV	16-40 kA	600-2000A	36" Wide Metal-Clad Switchgear or Upgrades to Existing Switchgear
	IEC 24 kV	125 kV	16-25 kA	630-2000A	
VCP-W	ANSI 38 kV	170 kV	16-40 kA, 1500 MVA	600-2500A	42" Wide Metal-Clad Switchgear
VCP-W (Outdoor)	ANSI 15.5 kV	110 kV	16-31.5 kA	600-1200A	Outdoor Station Distribution Breakers
W-VAC	IEC 3.6-17.5 kV	40-95 kV	16-40 kA	630-2000A	600-750 mm Wide IEC Medium Voltage Switchgear
W-VAC	IEC 3.6-17.5 kV	40-95 kV	31.5-50 kA	2500-3150A	1000 mm Wide IEC Medium Voltage Switchgear
W-VAC	IEC 36 kV	170 kV	16-31.5 kA	630-2000A	42" Wide IEC Metal-Clad Switchgear
DHP-VR	ANSI 5-15 kV	60-95 kV	250-1000 MVA	1200-3000A	DHP Metal-Clad Switchgear Technology Upgrades with the DHP-VR Direct Roll-in Vacuum Replacement Breakers from the Original Manufacturer
VCP-WR Series 18, 20, and 29	ANSI 5-15 kV	60-95 kV	250-1500 MVA	1200-3000A	Modular Fixed Vacuum Circuit Breakers in 18", 20", and 29" Widths for Conversions/Retrofits, Metal Enclosed Switchgear and Mining Switchgear
VCP-WC	ANSI 5-17.5kV	95kV	25-63kA	1200-3000A	36" wide Metal-Clad Switchgear
VCP-WG	ANSI 5-15kV	95kV	50-63kA	1200-3000A	36" wide Metal-Clad Switchgear
VCP-T	ANSI 5-15kV	95kV	16-25kA	800-1200A	Smaller frame breaker
VCP-TR	IEC 3.6-17.5kV	95kV	16-25kA	630-1250A	Smaller frame breaker

Eaton Corporation
Cutler-Hammer business unit
1000 Cherrington Parkway
Moon Township, PA 15108
United States
tel: 1-800-525-2000
www.cutler-hammer.com

© 2003 EATON CORPORATION
ALL RIGHTS RESERVED
PRINTED IN USA
FORM NO. BR01301006E
SEPTEMBER 2003

