

Type VCP-W Manual Ground and Test Device (Complex)

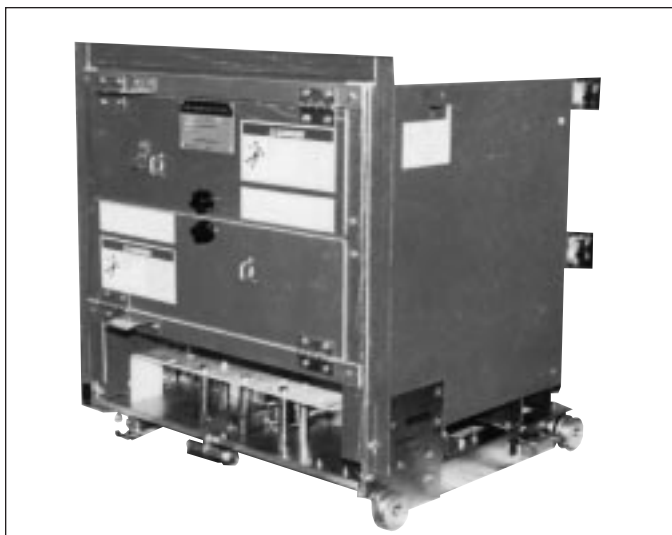

Figure 1 Type VCP-W Manual Ground and Test Device

TABLE OF CONTENTS

1-0	Introduction	1
1-1	Description	1
1-2	Operation	2



WARNING

READ AND UNDERSTAND THESE INSTRUCTIONS BEFORE ATTEMPTING TO USE THIS DEVICE. IMPROPER USE CAN RESULT IN DEATH, BODILY INJURY AND/OR PROPERTY DAMAGE.



CAUTION

BECAUSE OF THE UNIQUE APPLICATION AND VAST VARIETY OF SYSTEM AND USER REQUIREMENTS, SPECIFIC OPERATING PROCEDURES MUST BE DEVELOPED BY THE USER. FAILURE TO DEVELOP THESE PROCEDURES COULD LEAD TO IMPROPER USE OR OTHER MORE SERIOUS CONSEQUENCES.

1-0 INTRODUCTION

Type Vac Clad-W switchgear assemblies are designed with all the bus work completely insulated for safety. Since the current carrying parts are not readily accessible, type VCP-W Manual Ground and Test Device is designed for insertion into the breaker compartment to gain access to the primary stationary contacts. It provides a convenient means to:

1. Ground a circuit for maintenance work;
2. Apply potential for cable testing; and,
3. Access both bus and line circuits for "phasing out" tests.



CAUTION

BECAUSE OF THE UNIQUE APPLICATION AND VAST VARIETY OF SYSTEM/USER REQUIREMENTS, SPECIFIC SAFE OPERATING PROCEDURES FOR THE USE OF THIS DEVICE MUST BE DEVELOPED BY THE USER.

1-1 DESCRIPTION

The device consists of a drawout element that can be inserted into a circuit breaker compartment in the same manner as a type VCP-W circuit breaker. It includes six terminals and ground bus connections. Each terminal is isolated from each other and the ground bus connection by insulating barriers. The upper and lower terminals are accessible upon opening the respective front hinged door. The ground connection is located in the lower front section of the device.

Vac Clad-W switchgear is a two-high arrangement. In the lower compartment the top terminals normally connect to the main bus and the bottom terminals normally connect to the incoming line or feeders. In an upper compartment, the opposite normally holds true, i.e., the top terminals connect to the incoming line or feeders and the bottom terminals connect to the main bus. This must be verified for each application. Because of this two-high arrangement, the bus and the line positions of the grounding and test device terminals will vary depending upon whether the device is used in an upper or lower compartment. Therefore, **it is most important that the bus or line terminals be correctly identified for each compartment before using this device.**

Code plates are provided to prevent insertion of 1200/2000 amp device into 3000 amp compartment and vice-versa. Type VCP-W manual grounding and test devices are also available with either the upper or the lower terminals only. Devices of the same rating with only the upper terminals or with only the lower terminals are coded to make them non-interchangeable by the addition of an overlay code plate 8243A53H01 in the breaker compartments.

1-2 OPERATION



WARNING

READ AND UNDERSTAND THESE INSTRUCTIONS BEFORE ATTEMPTING TO USE THIS DEVICE. IMPROPER USE CAN RESULT IN DEATH, BODILY INJURY AND/OR PROPERTY DAMAGE.

The following general safe practices are recommended:

- Store the device in a clean, dry area free from dust, dirt, moisture, etc.
- Keep all insulating surfaces, which include primary support insulation and insulation barriers, clean and dry.
- Check all primary circuit connections to make certain that they are clean and tight.
- Permit only authorized trained personnel to use this device.
- Take extreme care while using this device to avoid contacting “Live” or “Hot” (energized) terminals.
- **Correctly identify line and bus terminals for the breaker compartment before using this device.**
- Check for correct code plate(s) on the device. Do not attempt to force the device into the compartment.

The grounding of either upper or lower terminals is accomplished by connecting cables (provided with the device) from either the upper or the lower terminals to the device ground connection. Cable testing or “phasing out” testing may be accomplished by connecting suitable test equipment, as required to the terminals.

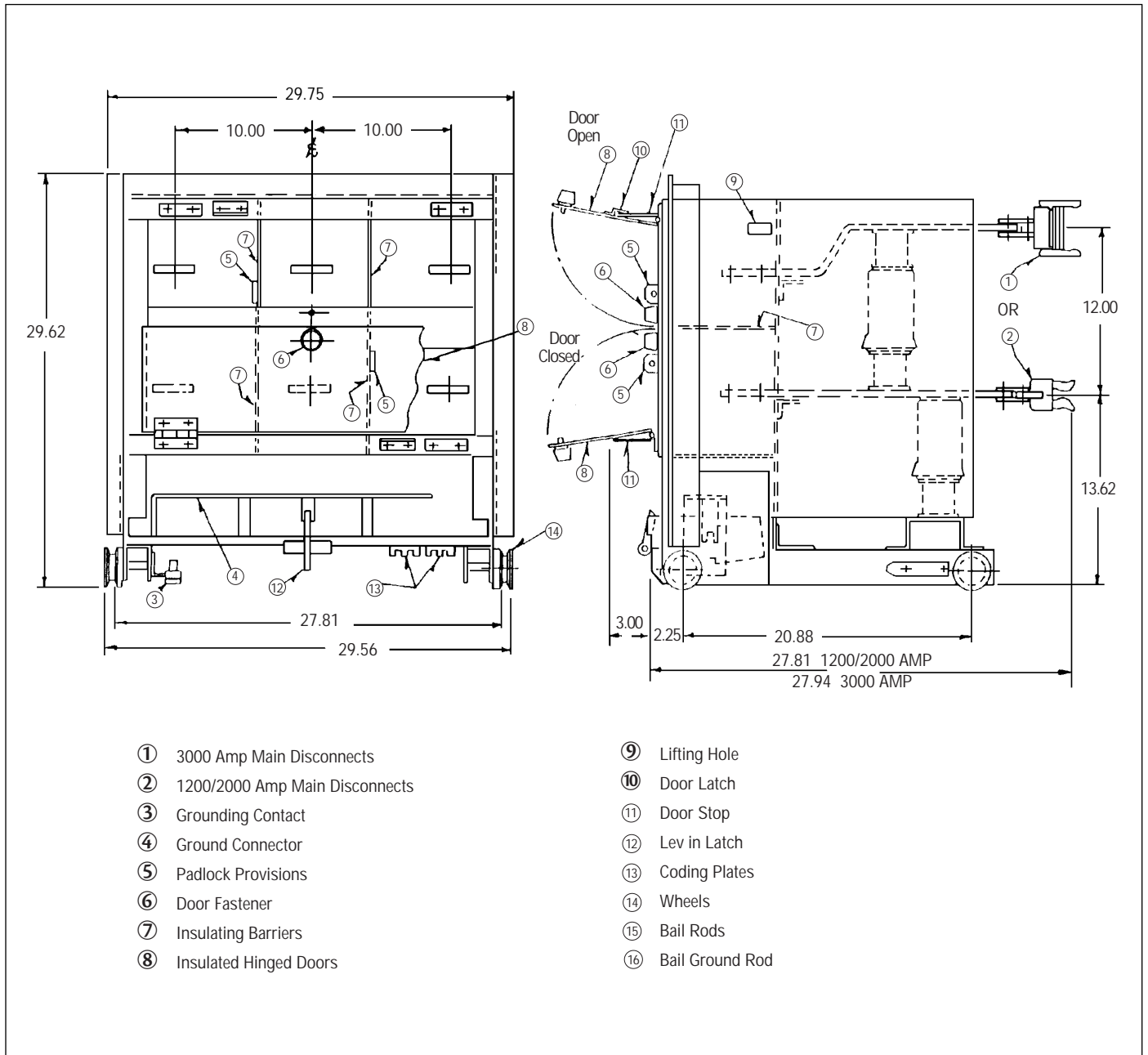

Figure 2 Standard Device

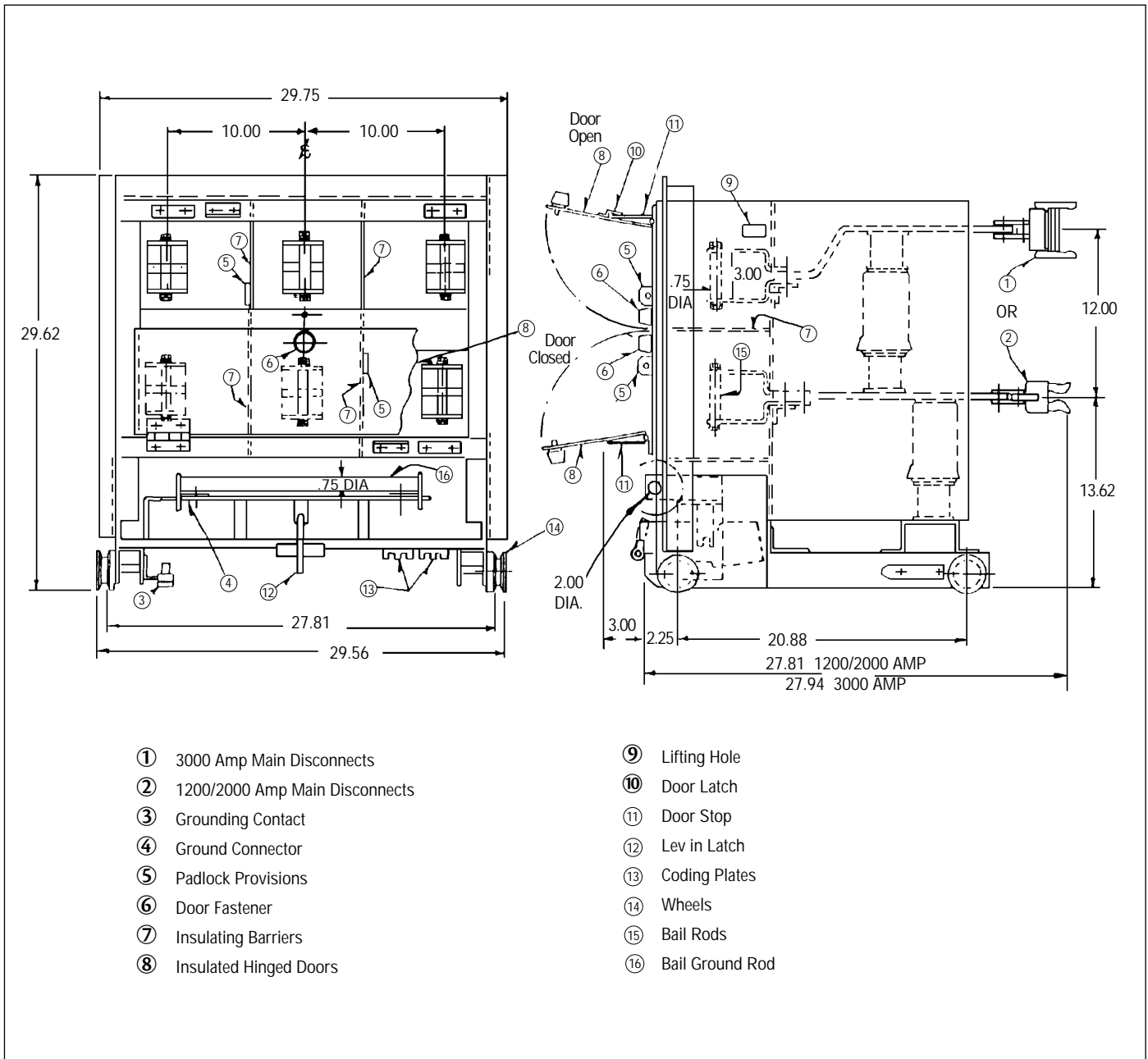
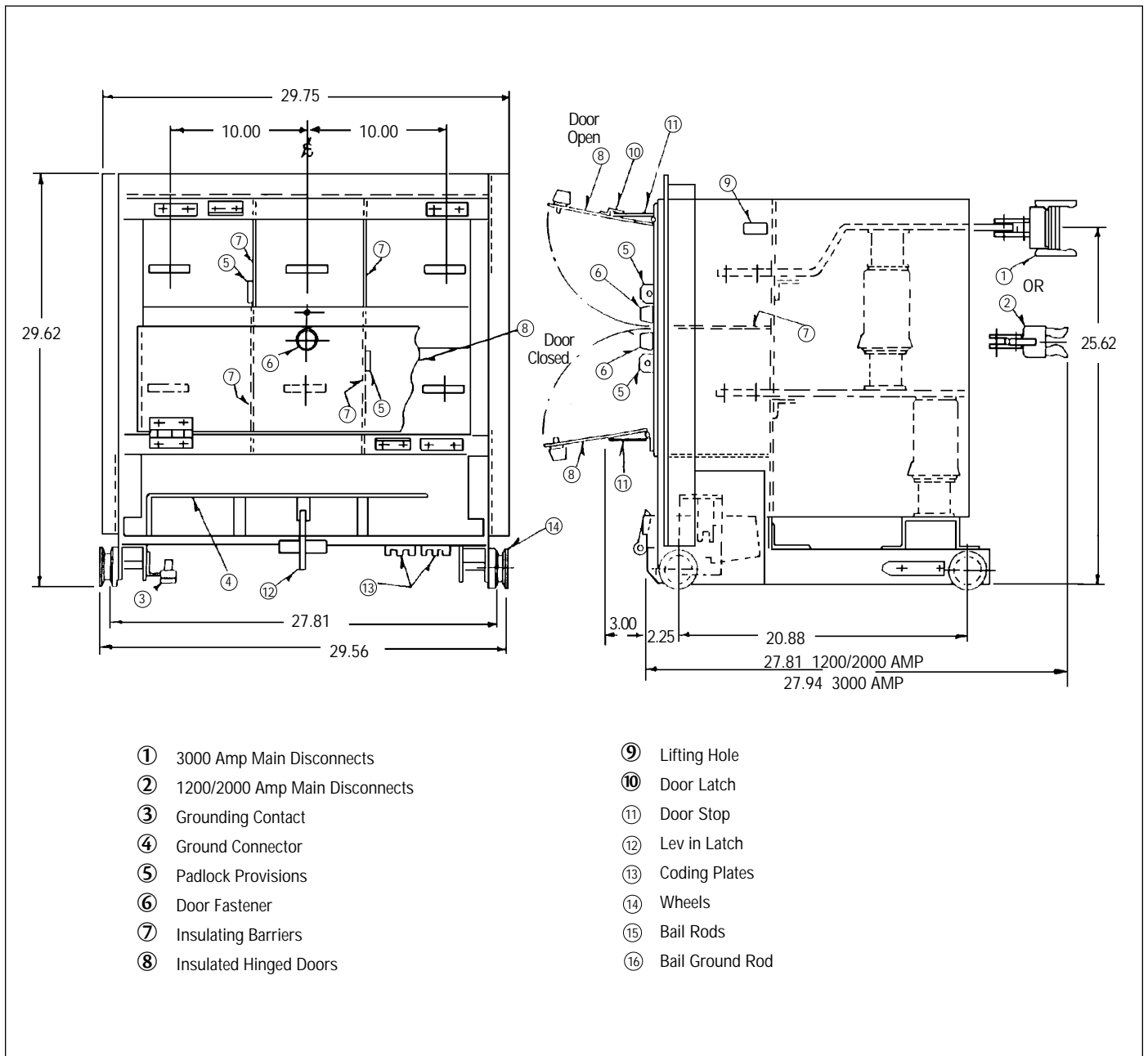

Figure 3 Device With Bails



- | | |
|----------------------------------|-------------------|
| ① 3000 Amp Main Disconnects | ⑨ Lifting Hole |
| ② 1200/2000 Amp Main Disconnects | ⑩ Door Latch |
| ③ Grounding Contact | ⑪ Door Stop |
| ④ Ground Connector | ⑫ Lev in Latch |
| ⑤ Padlock Provisions | ⑬ Coding Plates |
| ⑥ Door Fastener | ⑭ Wheels |
| ⑦ Insulating Barriers | ⑮ Bail Rods |
| ⑧ Insulated Hinged Doors | ⑯ Bail Ground Rod |

Figure 4 Standard Device (Upper)

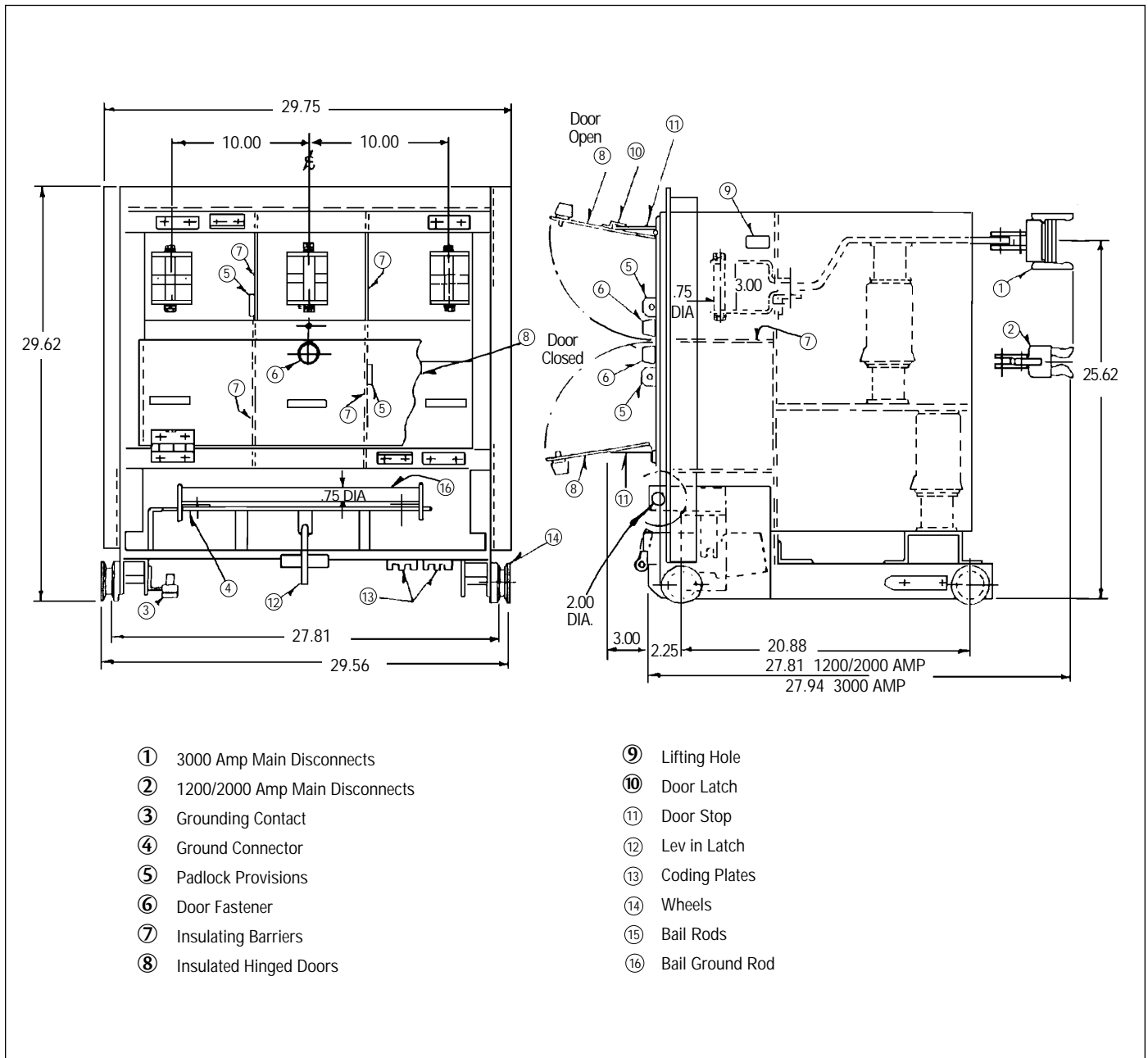

Figure 6 Device With Bails (Upper)

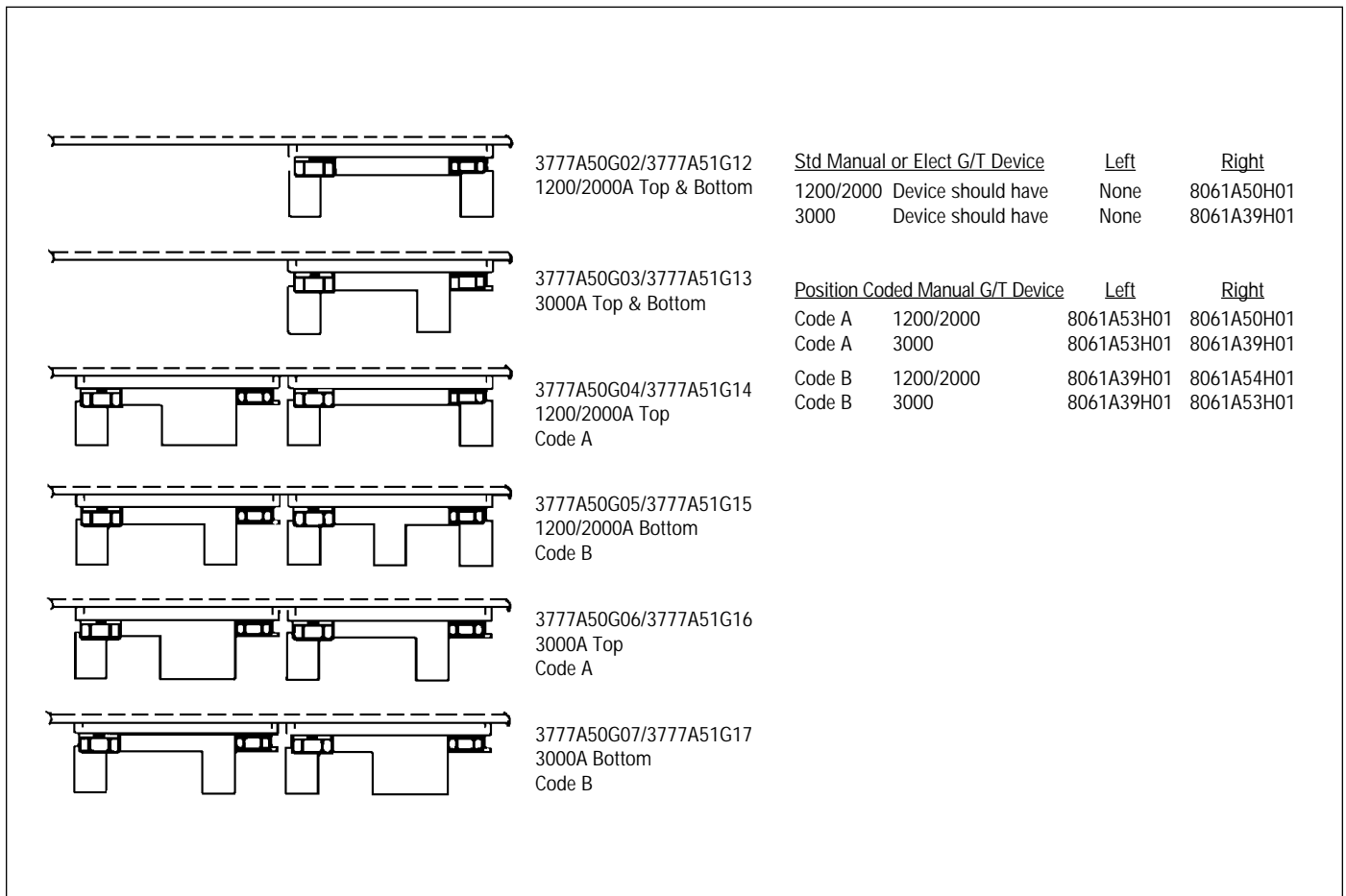

Figure 8 Code Plate Legend

