

Trip indicator with manual reset in Magnum low voltage circuit breakers

⚠ WARNING

- (1) ONLY QUALIFIED ELECTRICAL PERSONNEL SHOULD BE PERMITTED TO WORK ON THE EQUIPMENT
- (2) ALWAYS DE-ENERGIZE PRIMARY AND SECONDARY CIRCUITS IF A CIRCUIT BREAKER CANNOT BE REMOVED TO A SAFE WORK LOCATION
- (3) DRAWOUT CIRCUIT BREAKERS SHOULD BE LEVERED (RACKED) OUT TO THE DISCONNECT POSITION.
- (4) ALL CIRCUIT BREAKERS SHOULD BE SWITCHED TO THE OFF POSITION AND MECHANISM SPRINGS DISCHARGED.

FAILURE TO FOLLOW THESE STEPS FOR ALL PROCEDURES DESCRIBED IN THIS INSTRUCTION LEAFLET COULD RESULT IN DEATH, BODILY INJURY, OR PROPERTY DAMAGE.

⚠ WARNING

THE INSTRUCTIONS CONTAINED IN THIS IL AND ON PRODUCT LABELS MUST BE FOLLOWED. OBSERVE THE FIVE SAFETY RULES.

- **DISCONNECTING;**
- **ENSURE THAT DEVICES CANNOT BE ACCIDENTALLY RESTARTED;**
- **VERIFY ISOLATION FROM THE SUPPLY;**
- **EARTHING AND SHORT-CIRCUITING; AND;**
- **COVERING OR PROVIDING BARRIERS TO ADJACENT LIVE PARTS.**

Section 1: General information

A red, pop-out mechanical trip indicator is an optional feature located above the trip unit on the breaker's front faceplate. It operates by releasing and popping out any time the circuit breaker trips due to an overcurrent condition or by an enhanced protection feature (if programmed, available on Digitrip 1150+ and PXR).

An optional overcurrent trip switch (bell alarm) that is operated by the position of the mechanical trip indicator is also available. The switch is reset when the trip indicator is reset.

This product is intended for use in Magnum circuit breakers with PXR or Digitrip trip units.

Note: All images show a Magnum circuit breaker with a PXR trip unit unless stated otherwise. Some components, such as the trip unit, not shown for clarity. Trip indicator assembly is shown with optional overcurrent trip switches in images.

Required tools

- 1/4-inch socket drive (with torque measuring capabilities)
- 10 mm socket
- Phillips head screwdriver (#2 recommended)

Kit parts identification

Refer to **Figure 1** for visual identification of the parts listed below:

- (A) Trip indicator (one)
- (B) Accessory kit labels (one)
- (C) M3.5 x 13 hi-lo screw (two)
- (D) M3.5 flat washer (two)

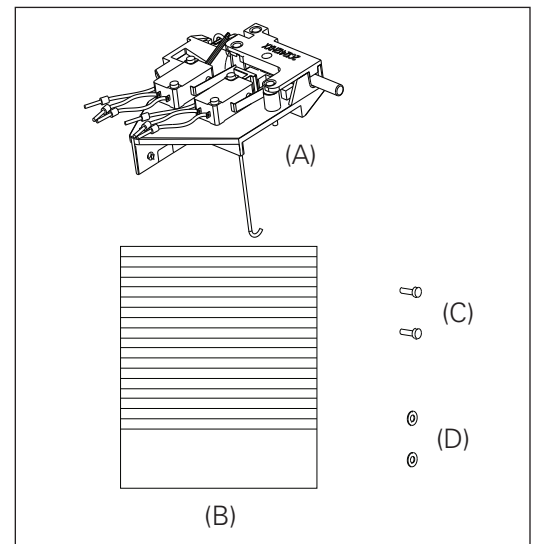

Figure 1. Contents of kit.

EATON

Powering Business Worldwide

Section 2: Installation of manual reset trip indicator kit

Proceed with the following steps:

Step 1: Remove the front cover by unscrewing the hex-head captive bolts (four for three-pole, six for four-pole) that join the cover to the breaker housing using a 10 mm 1/4-inch drive socket. Then hold the charge handle down approximately 45 degrees to pull off the cover.

Step 2: Place the trip indicator option label (B) on the front cover nameplate space located under "Accessories."

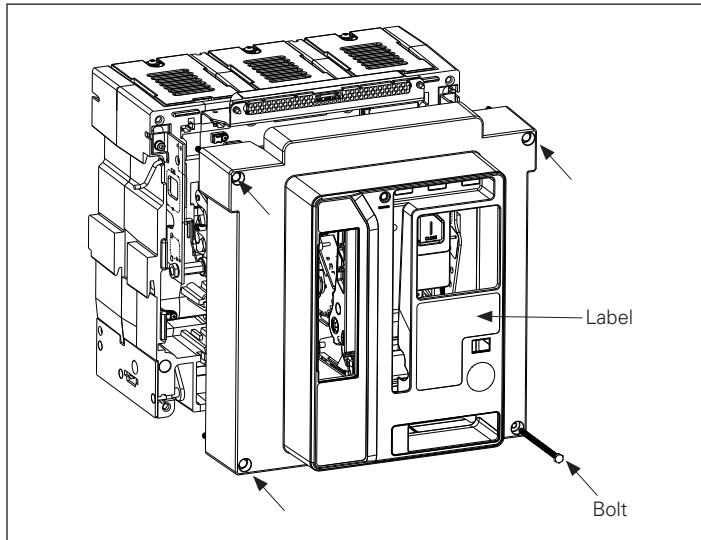

Figure 2. Step 1 and Step 2.

Step 3: First insert the hooked end hanging from the trip indicator through the hole in the lever on the mechanism.

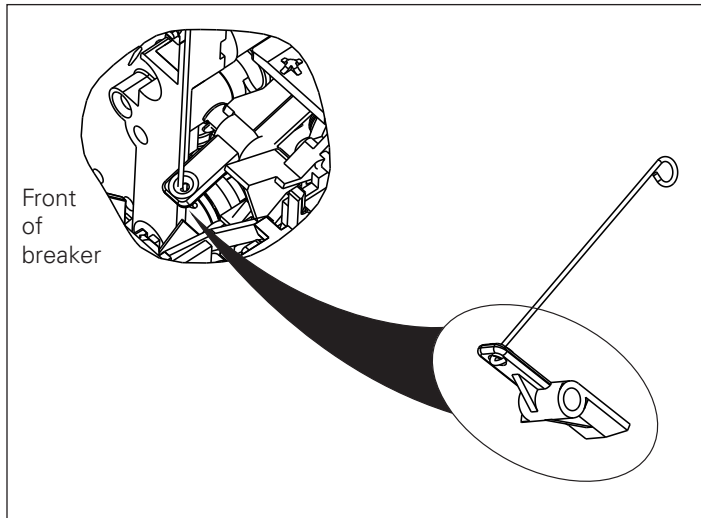

Figure 3. Step 3

Step 4: If the installed trip unit is a Digitrip 520 trip unit or a PXR trip unit, skip this step and proceed directly to Step 5. If the installed trip unit is a Digitrip 1150 trip unit, complete this step as outlined below and then proceed to Step 6.

Mount the trip indicator assembly to the top two posts of the trip unit's mounting deck directly above the Digitrip 1150 trip unit using the supplied hardware (two M3.5 x 13 hi-lo screws (C), two M3.5 flat washers (D)) as shown. Torque to 18–22 in-lbs (2.0–2.5 Nm).

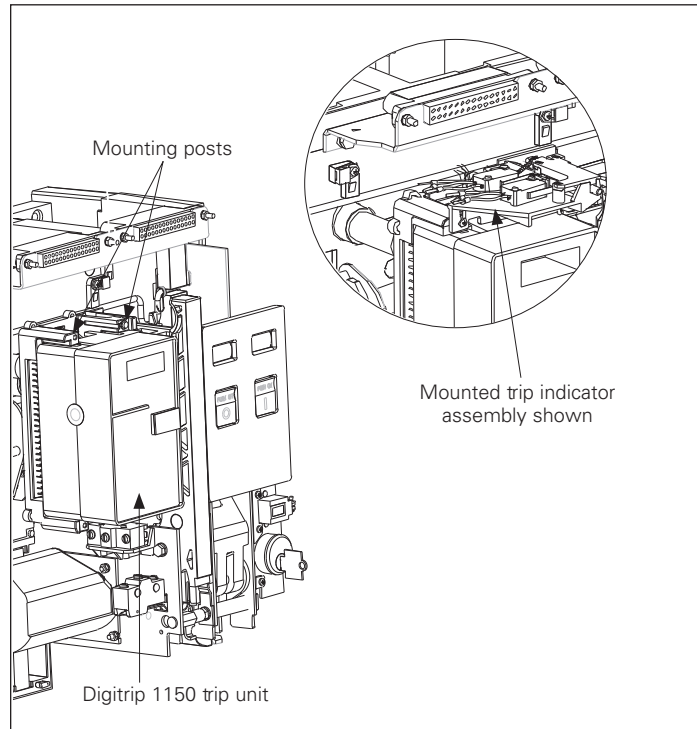

Figure 4. Step 4 Magnum with a Digitrip 1150.

Step 5: If the installed trip unit is a Digitrip 520 trip unit or a PXR trip unit, and a metal plate is already mounted to the two top posts of the trip unit's mounting deck, remove the two screws from the top of the mounting plate. Position the trip indicator assembly between the metal plate and the two mounting posts. Secure the trip indicator assembly and the metal plate in position using the two mounting screws just removed. Torque to 18–22 in-lbs (2.0–2.5 Nm).

Note: The trip indicator (A) is shown, with optional overcurrent trip switches, here without the push rod attached for mounting orientation illustration only.

Step 6: After installation, verify that the trip indicator assembly remains latched when the breaker is operated with the push buttons. Verify that the mechanical trip indicator trips when the breaker opens with the trip actuator.

Step 7: Static trip actuator test—As the trip latch rotates slowly, the trip actuator must not trip before the breaker trips. The indicator may not trip during this test but the breaker must trip.

Step 8: Optional overcurrent trip switch (bell alarm) wiring installation:

If the indicator assembly was supplied with an overcurrent trip switch (bell alarm) wiring option, wire to the secondary connector as referenced in **Table 1**. Terminal maps for the secondary connectors are located on top of the secondary connectors.

Verify that the overcurrent trip switches are in the open position when the trip indicator has tripped. Verify that the overcurrent trip switches are in the closed position when the trip indicator has not tripped.

Table 1. Secondary connector overcurrent trip switch positions

Trip unit	OTS 1 make	OTS 1 com	OTS 1 break	OTS 2 make	OTS 2 com	OTS 2 break
Digitrip (Fig. 5)	A1	A2	A3	A4	A5	A6
PXR (Fig. 6)	C1	C2	C3	C4	C5	C6

Step 9: Reinstall front cover removed in Step 1.

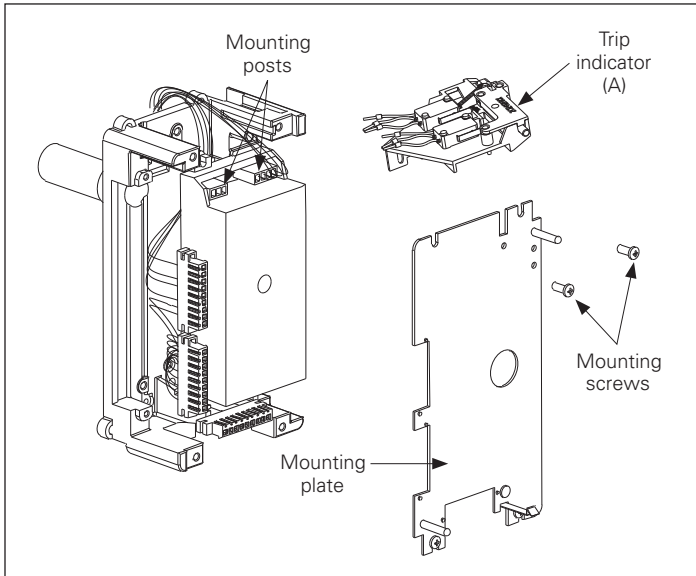

Figure 5. Step 5 Magnum with a Digitrip 520.

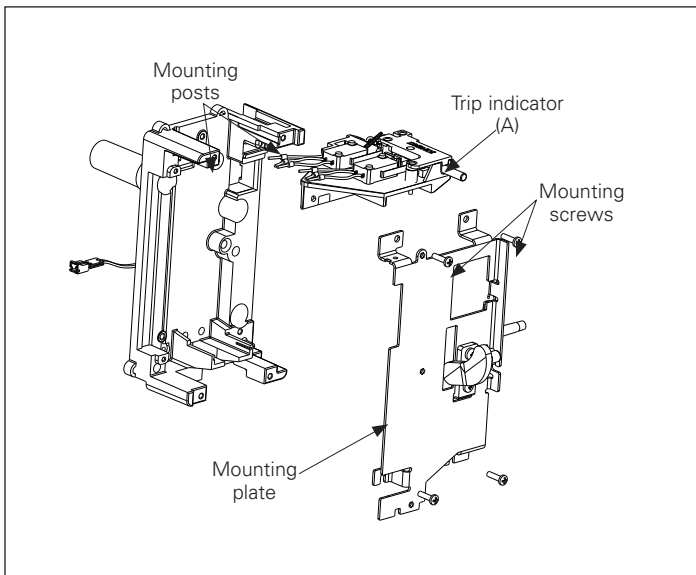

Figure 6. Step 5 Magnum with PXR.

Disclaimer of warranties and limitation of liability

The information, recommendations, descriptions, and safety notations in this document are based on Eaton Corporation's ("Eaton") experience and judgment, and may not cover all contingencies. If further information is required, an Eaton sales office should be consulted.

Sale of the product shown in this literature is subject to the terms and conditions outlined in appropriate Eaton selling policies or other contractual agreement between Eaton and the purchaser.

THERE ARE NO UNDERSTANDINGS, AGREEMENTS, WARRANTIES, EXPRESSED OR IMPLIED, INCLUDING WARRANTIES OF FITNESS FOR A PARTICULAR PURPOSE OR MERCHANTABILITY, OTHER THAN THOSE SPECIFICALLY SET OUT IN ANY EXISTING CONTRACT BETWEEN THE PARTIES. ANY SUCH CONTRACT STATES THE ENTIRE OBLIGATION OF EATON. THE CONTENTS OF THIS DOCUMENT SHALL NOT BECOME PART OF OR MODIFY ANY CONTRACT BETWEEN THE PARTIES.

In no event will Eaton be responsible to the purchaser or user in contract, in tort (including negligence), strict liability, or otherwise for any special, indirect, incidental, or consequential damage or loss whatsoever, including but not limited to damage or loss of use of equipment, plant or power system, cost of capital, loss of power, additional expenses in the use of existing power facilities, or claims against the purchaser or user by its customers resulting from the use of the information, recommendations, and descriptions contained herein.

The information contained in this manual is subject to change without notice.

Eaton
1000 Eaton Boulevard
Cleveland, OH 44122
United States
Eaton.com

© 2022 Eaton
All Rights Reserved
Printed in USA
Publication No. IL2C14893H02/TBG 001573
January 2022