

# Spring release latch check switch (LCS) for Magnum low voltage circuit breakers

## ⚠ WARNING

- (1) ONLY QUALIFIED ELECTRICAL PERSONNEL SHOULD BE PERMITTED TO WORK ON THE EQUIPMENT
- (2) ALWAYS DE-ENERGIZE PRIMARY AND SECONDARY CIRCUITS IF A CIRCUIT BREAKER CANNOT BE REMOVED TO A SAFE WORK LOCATION
- (3) DRAWOUT CIRCUIT BREAKERS SHOULD BE LEVERED (RACKED) OUT TO THE DISCONNECT POSITION.
- (4) ALL CIRCUIT BREAKERS SHOULD BE SWITCHED TO THE OFF POSITION AND MECHANISM SPRINGS DISCHARGED.

FAILURE TO FOLLOW THESE STEPS FOR ALL PROCEDURES DESCRIBED IN THIS INSTRUCTION LEAFLET COULD RESULT IN DEATH, BODILY INJURY, OR PROPERTY DAMAGE.

## ⚠ WARNING

THE INSTRUCTIONS CONTAINED IN THIS IL AND ON PRODUCT LABELS MUST BE FOLLOWED. OBSERVE THE FIVE SAFETY RULES.

- DISCONNECTING;
- ENSURE THAT DEVICES CANNOT BE ACCIDENTALLY RESTARTED;
- VERIFY ISOLATION FROM THE SUPPLY;
- EARTHING AND SHORT-CIRCUITING; AND;
- COVERING OR PROVIDING BARRIERS TO ADJACENT LIVE PARTS.

## Section 1: General information

A latch check switch (LCS) indicates when the circuit breaker is “ready to close” (**Figure 1**). The Internal version of the LCS is wired to the spring release. It will not permit activation of the spring release until the circuit breaker is fully charged and the trip latch is reset.

This product is intended for use in Magnum circuit breakers with PXR or Digitrip trip units.

### Required tools

- 1/4-inch drive ratchet
- 10 mm socket

### Kit parts identification

Refer to **Figure 1** for visual identification of the contents of kit:

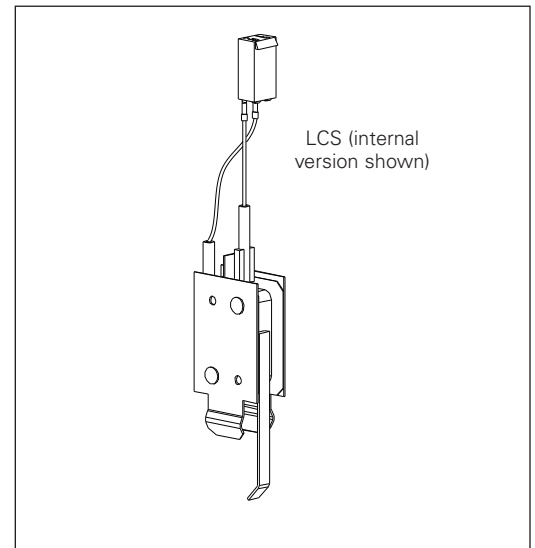

**Figure 1. Contents of kit.**

**Note:** All images show a Magnum circuit breaker with a PXR trip unit unless stated otherwise. Some components, such as the trip unit, not shown for clarity.

# EATON

Powering Business Worldwide

## Section 2: Installation of internal remote LCS

To install the LCS, proceed with the following steps:

**Step 1:** Remove the front cover by unscrewing the hex-head captive bolts (four for three-pole, six for four-pole) that join the cover to the breaker housing using a 10 mm 1/4-inch drive socket. Then hold the charge handle down at about a 45-degree angle to pull off the cover.

**Step 2:** Place the appropriate label on the front cover nameplate space located under "Accessories".

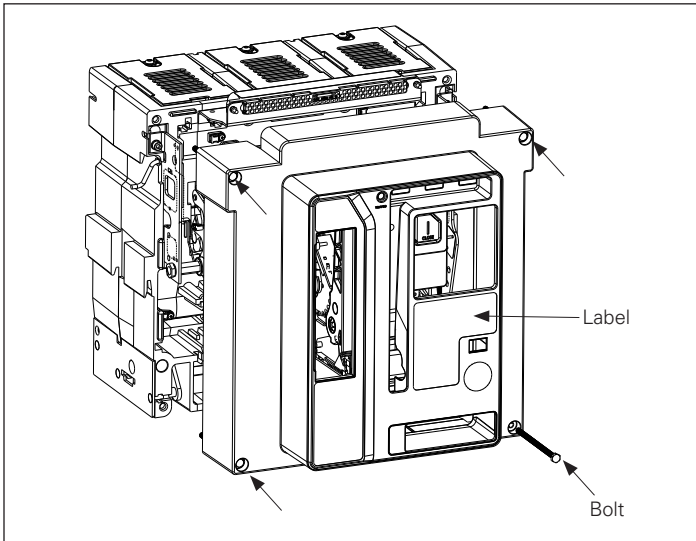

Figure 2. Steps 1 and 2.

**Step 3:** Remove the accessory (if installed) and the spring release (SR) from the indicated positions on the accessory tray by lifting its lock up and sliding the accessory toward the front of the breaker. Then lift accessory up and out of tray. Do not disconnect the wiring.

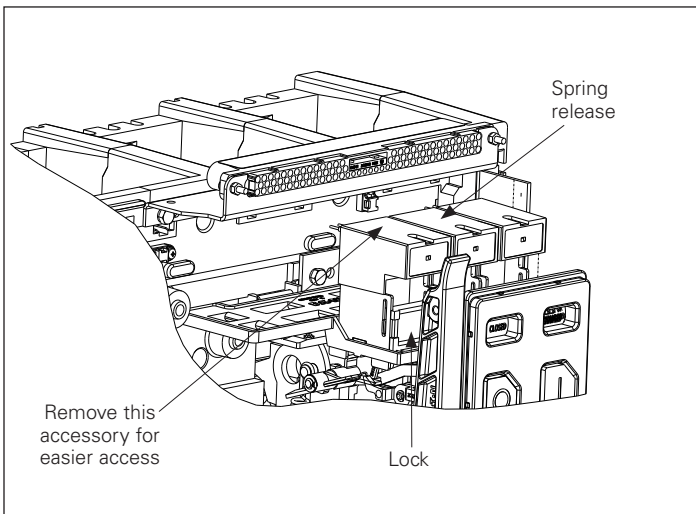

Figure 3. Step 3.

**Step 4:** Plug the connector from the LCS onto the two pins of the spring release circuit board. Then push the LCS into the slot in the accessory tray. Make sure the LCS is fully seated.

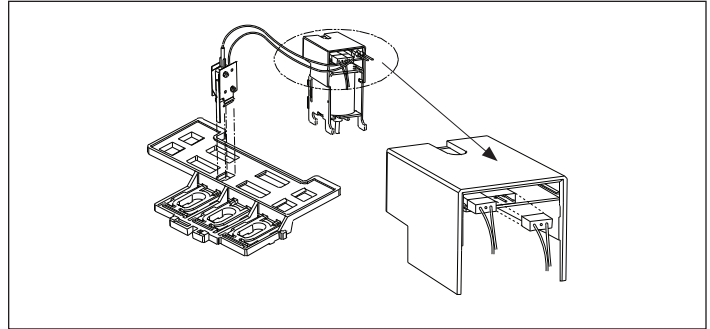

Figure 4. Step 4.

**Step 5:** Reinstall any accessory that was removed in Step 3.

**Step 6:** Test the installation.

### CAUTION

**PUSH THE OFF BUTTON FIRST TO ENSURE THAT THE BREAKER IS NOT CLOSED. FAILURE TO FOLLOW THIS ACTION COULD RESULT IN A SERIOUS INJURY.**

With the breaker OPEN and DISCHARGED, push down on the trip lever platform (to its stop) and release. The LCS should not operate. This is indicated by the absence of an audible "click" from the switch.

Now charge the breaker using the manual handle. When the breaker is fully charged, the trip lever will return to the latched (platform level) position. Repeat the above test by pushing the trip lever platform down and releasing it. An audible "click" from the switch should be heard.

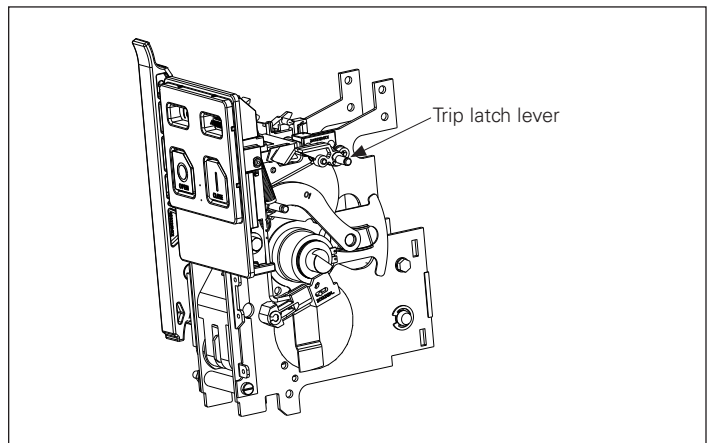

Figure 5. Step 6.

**Step 7:** Reinstall the front cover. Push the CLOSE and then the OPEN pushbuttons to discharge all energy from the mechanism, leaving it in an OPEN and DISCHARGED status.

**Notes:**

## Disclaimer of warranties and limitation of liability

The information, recommendations, descriptions, and safety notations in this document are based on Eaton Corporation's ("Eaton") experience and judgment, and may not cover all contingencies. If further information is required, an Eaton sales office should be consulted.

Sale of the product shown in this literature is subject to the terms and conditions outlined in appropriate Eaton selling policies or other contractual agreement between Eaton and the purchaser.

THERE ARE NO UNDERSTANDINGS, AGREEMENTS, WARRANTIES, EXPRESSED OR IMPLIED, INCLUDING WARRANTIES OF FITNESS FOR A PARTICULAR PURPOSE OR MERCHANTABILITY, OTHER THAN THOSE SPECIFICALLY SET OUT IN ANY EXISTING CONTRACT BETWEEN THE PARTIES. ANY SUCH CONTRACT STATES THE ENTIRE OBLIGATION OF EATON. THE CONTENTS OF THIS DOCUMENT SHALL NOT BECOME PART OF OR MODIFY ANY CONTRACT BETWEEN THE PARTIES.

In no event will Eaton be responsible to the purchaser or user in contract, in tort (including negligence), strict liability, or otherwise for any special, indirect, incidental, or consequential damage or loss whatsoever, including but not limited to damage or loss of use of equipment, plant or power system, cost of capital, loss of power, additional expenses in the use of existing power facilities, or claims against the purchaser or user by its customers resulting from the use of the information, recommendations, and descriptions contained herein.

The information contained in this manual is subject to change without notice.

**Eaton**  
1000 Eaton Boulevard  
Cleveland, OH 44122  
United States  
Eaton.com

© 2021 Eaton  
All Rights Reserved  
Printed in USA  
Publication No. IL2C12769H08/TBG 001546  
December 2021