

Instructions for Digitrip RMS 610 Trip Unit

Table of Contents	Page
1.0 General Description - RMS 610 Trip Unit System	1
1.1 Basic RMS 610 Trip Unit	1
1.1.1 Operational Status and TRIP Indicators.	2
1.1.2 General Over-Current Protection	2
1.1.3 DIScriminator (Making Current Release)	4
1.1.4 OverRiDe (Fixed Instantaneous) TRIP	4
1.1.5 Zone Interlocking	7
1.2 Four-Character Information Display Window	7
1.2.1 Values Displayed During Normal Service	7
1.2.2 Messages for ALARM or TRIP Conditions	7
1.2.2.1 "ROM Error... See I.L."	8
1.3 Rating Plugs, Frame Ratings, Sensor Ratings.	8
1.4 Power / Relay Module	11
1.5 Auxiliary Power Module	12
2.0 UL Listed Devices	12
3.0 Protection Settings.	12
3.1 General	12
3.2 Long Delay Current Setting	13
3.3 Long Delay Time Setting	13
3.4 Short Delay Current Setting	13
3.5 Short Delay Time Setting	13
3.6 Instantaneous Current Setting	14
3.7 NO Instantaneous Current Setting	14
3.8 Ground Fault Current Setting.	14
3.9 Ground Fault Time Delay Setting	15
4.0 Test Procedures	15
4.1 General	15
4.2 When to Test	16
4.3 Testing Provisions	16
4.4 Conducting Tests	16
4.4.1 Not Tripping the Breaker	17
4.4.2 Tripping the Breaker	18
4.5 Testing Back-up Battery - Inside Rating Plug	18
4.5.1 Back-up Battery Check	18
4.5.2 Replacing the Back-up Battery	18
5.0 References	19
5.1 Digitrip RMS Trip Unit Assemblies	19
5.2 DS / DSL Low-Voltage AC Power Ckt. Breakers	19
5.3 SPB Systems Pow-R Circuit Breakers	19
5.4 Series C [®] R-Frame Molded Case Ckt. Breakers	19
Lists of Figures, Tables, and Appendices.	19

RESULT FROM CONTACT WITH ENERGIZED EQUIPMENT. ALWAYS VERIFY THAT NO VOLTAGE IS PRESENT BEFORE PROCEEDING WITH THE TASK, AND ALWAYS FOLLOW GENERALLY ACCEPTED SAFETY PROCEDURES. EATON IS NOT LIABLE FOR THE MISAPPLICATION OR MISIN-STALLATION OF ITS PRODUCTS.

It is strongly urged that the user observe all recommendations, warnings and cautions relating to the safety of personnel and equipment, as well as all general and local health and safety laws, codes, and procedures.

The recommendations and information contained herein are based on experience and judgment, but should not be considered to be all-inclusive or covering every application or circumstance which may arise. If you have any questions or need further information or instructions, please contact your local representative, or the Customer Support Center for the type of circuit breaker you have.

Circuit Breaker Type	Call Telephone Number	Send to FAX Number
DS/DSL	(412) 937-6029	(412) 937-6396
SPB	(412) 937-6029	(412) 937-6396
Series C	(412) 937-6490	(412) 937-6010
R-Frame		

1.0 GENERAL DESCRIPTION - DIGITRIP RMS 610 TRIP UNIT

1.1 Basic Digitrip RMS 610 Trip Unit

The Digitrip RMS 610, illustrated in Fig.1, is a Trip Unit, suitable for use in types DS and DSL Low-Voltage AC power circuit breakers and type SPB Systems Pow-R circuit breakers and Series C R-Frame molded case circuit breakers. The Digitrip RMS 610 Trip Unit provides four basic functions:

Function	Section
Protection	1.1.2 - 1.1.5 and 3
Information	1.1.1 and 1.2
Monitors Current	1.2.1
Testing	4

Digitrip RMS 610 provides true RMS current sensing for proper correlation with the thermal characteristics of conductors and equipment. Interchangeable rating plugs are provided to establish the continuous current rating of



WARNING

DO NOT ATTEMPT TO INSTALL OR PERFORM MAINTENANCE ON EQUIPMENT WHILE IT IS ENERGIZED. DEATH OR SEVERE PERSONAL INJURY CAN

each circuit breaker. The Digitrip RMS 610 Trip Unit is designed for use in industrial circuit breaker environments where the ambient temperatures can range from -20 C to +85 C and rarely exceed 70 to 75 C. If, however, temperatures in the neighborhood of the Trip Unit do exceed this range, the Trip Unit performance may be degraded. In order to insure that the tripping function is not compromised due to an over-temperature condition, the Digitrip RMS 610 microcomputer chip has a built-in over-temperature protection feature, factory set to trip the breaker if the chip temperature exceeds 95 C. If over-temperature is the reason for the trip, the Long Delay Time LED will light "RED", and the word "TEMP" will appear in the display window.

The Trip Unit employs the Eaton custom

designed integrated circuit $S\mu RE+$ ™ chip, which includes a micro-computer to perform its numeric and logic functions. The principle of operation is described by the block diagram shown in Fig. 2.

In the Digitrip RMS 610 Trip Unit, all required sensing and tripping power to operate its **protection function** is derived from the current sensors in the circuit breaker. The secondary currents from these sensors provide the correct input information for the protection functions, as well as tripping power, whenever the circuit breaker is carrying current. These current signals develop analog voltages across the appropriate calibrating resistors including:

- 1) Phase currents
- 2) Ground current or Neutral current (when supplied)
- 3) Rating plug

The resulting analog voltages are digitized by the custom designed integrated circuits. The micro-computer, in cyclic fashion, repeatedly scans the voltage values across each calibrating resistor and enters these values into its Random Access Memory (RAM). These data are used to calculate true RMS current values, which are then repeatedly compared with the protection function settings and other operating data stored in the memory. The software program then determines whether to initiate protection functions, including tripping the breaker through the low energy trip device (Flux Transfer Shunt Trip or Direct Trip Actuator) in the circuit breaker.

1.1.1 Operational Status and Protection TRIP Indicators

The "Green" Light Emitting Diode (LED) in the lower right corner of the Trip Unit (Fig. 1) "blinks" once each second to indicate the Trip Unit is operating normally.

Note: If the LED is steadily "GREEN", i.e. not blinking, the Trip Unit is not ready. Check the 120 VAC control power to the Power / Relay Module, if the LED is not blinking. (See Section 1.4.)

The LEDs, shown in Figs. 1 and 3.1 thru 3.6 on the face of the Trip Unit, light "RED" to indicate the reason for any automatic trip operation. As indicated in Figs. 3.1-3.6, each LED is strategically located in the related segment of the time-current curve depicted on the face of the Trip Unit. The reason for trip is identified by the segment of the time-current curve where the LED is lighted "RED", and shown by the "code" in the Display. Following an automatic protection trip operation, the external control power to the Power/Relay Module (See Section 1.4) will maintain the LED "RED" and will **continue** to send a **TRIP** signal to **LOCKOUT** the circuit breaker until the Trip Unit is **RESET**. The Digitrip RMS 610 Trip Unit can be **RESET** by pressing and releasing the "**TRIP RESET**" button. (See Fig. 1 lower right corner just above the "UNIT STATUS" LED.)

In the event that control power is lost, the back-up battery in the Rating Plug (See Section 1.3 and Figs. 1 and 4) continues to supply power to the LEDs. To check the status of the battery, see Section 4.5.

Note: The Digitrip RMS 610 performs all of its protection functions regardless of the status of the battery. The battery serves only to maintain the indication of the reason for automatic trip.

Press and release the "**TRIP RESET**" push-button shown in Fig. 1, to turn "Off" the LEDs following a trip operation.

1.1.2 General Over-Current Protection

The Digitrip RMS 610 Trip Unit is completely self-contained and when the circuit breaker is closed, requires no external control power to operate its **protection systems**. It operates from current signal levels and control power derived through current sensors integrally mounted in the circuit breaker.

The Digitrip RMS 610 Trip Unit is available in six different types. Each Trip Unit may be equipped with a maximum of five phase and two ground (time-current) settings (See Section 3) to meet specific application requirements. The protection available for each type is summarized in Table 1, and illustrated in Figures 3.1 through 3.6:

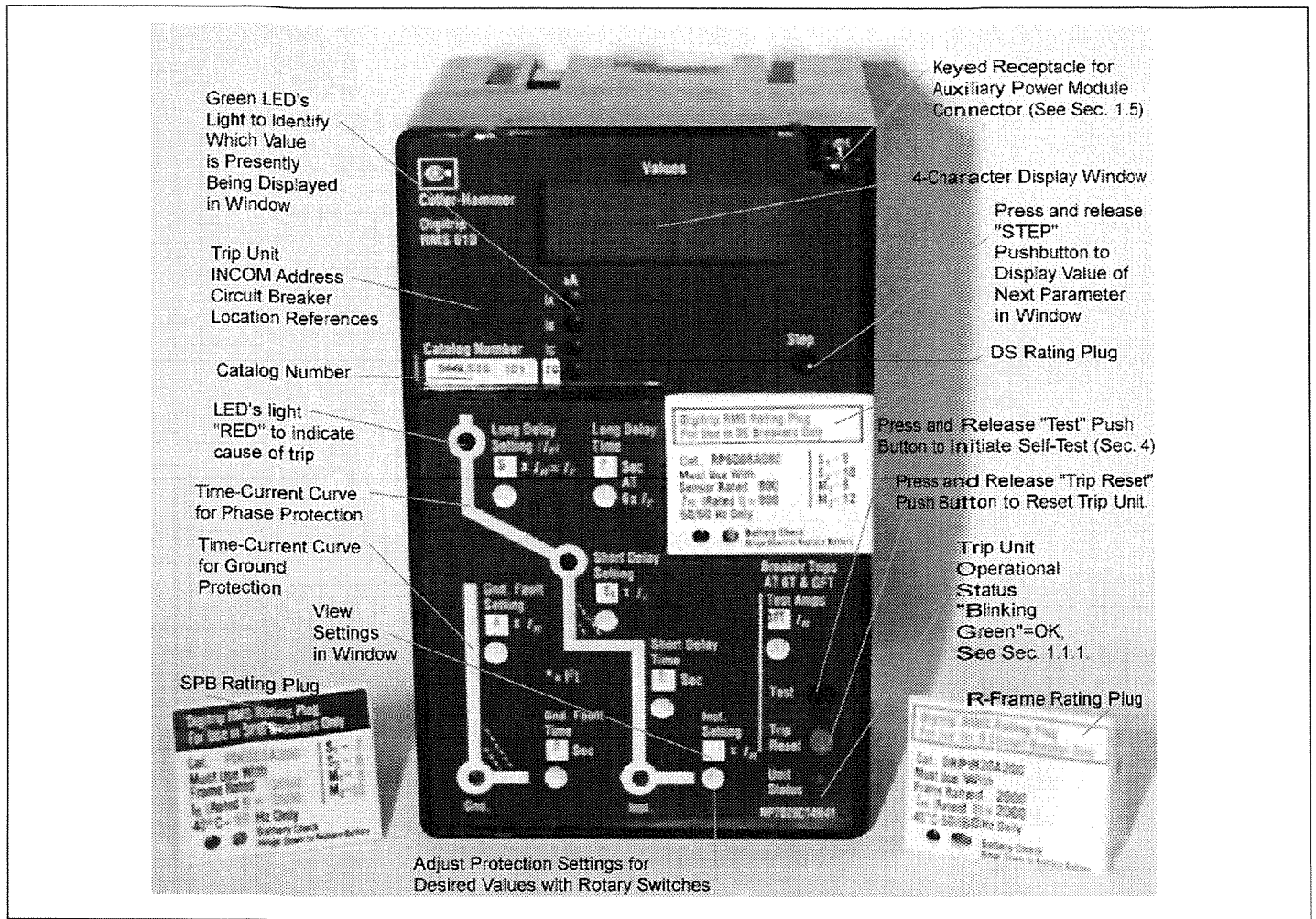

Fig. 1 Digitrip RMS 610 Trip Unit Type LSIG with Rating Plug

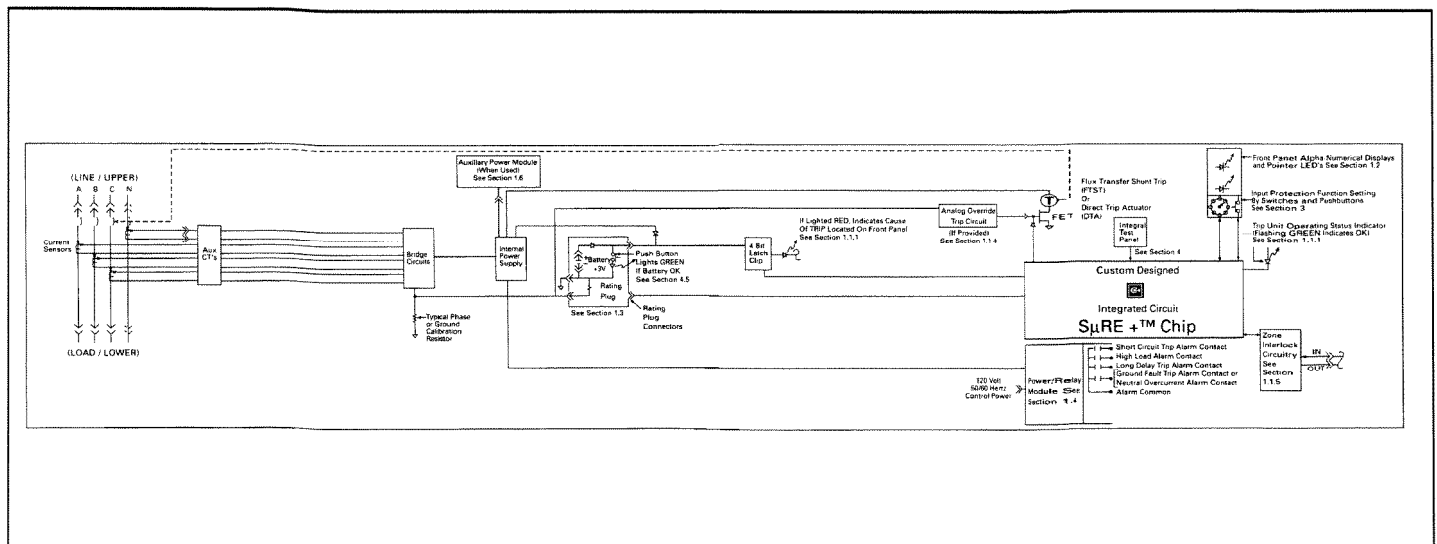

Fig. 2 RMS Digitrip 610 Trip Unit - Block Diagram

Protection Functions	Type	Figure
Long Time / Instantaneous	LI*	3.1
Long Time / Short Time	LS*	3.2
Long Time / Short Time / Instantaneous	LSI*	3.3
Long Time / Instantaneous / Ground	LIG	3.4
Long Time / Short Time / Ground	LSG	3.5
Long Time / Short Time / Instantaneous / Ground	LSIG	3.6

NOTE*: RMS Digitrip Type LI, LS and LSI Trip Units can be applied on 3-pole or 4-pole circuit breakers for protection of the neutral circuit, *IF the circuit breaker is wired and MARKED for NEUTRAL PROTECTION.* Refer to the National Electric Code for appropriate application of 4-pole breakers.



NOTICE

AFTER EACH TRIP OPERATION THE AUTOMATIC LOCKOUT AFTER-TRIP FEATURE OF THE DIGITRIP RMS 610 TRIP UNIT MAINTAINS THE CIRCUIT BREAKER IN A “TRIP-FREE” CONDITION, PROVIDED 120 VAC CONTROL POWER REMAINS AVAILABLE TO THE POWER / RELAY MODULE. THE TRIP UNIT MUST BE RESET, BEFORE THE CIRCUIT BREAKER CAN BE CLOSED AGAIN. THE RESET CAN BE ACCOMPLISHED BY PRESSING AND RELEASING THE “TRIP RESET” PUSH BUTTON. (SEE FIG. 1.)

After an over-current trip operation, the following information is stored in the Trip Unit memory:

- the cause of trip,
- the values of currents thru the breaker at time of trip.

1.1.3 DIScriminator (High Initial Current Release) (For Types LS and LSG Trip Units only)

When the Digitrip RMS 610 Trip Unit is not equipped with an adjustable instantaneous protection setting, i.e. types LS or LSG, a DIScriminator circuit (or high initial current release) is provided. The non-adjustable release is pre-set at eleven (11) times the installed rating plug current (I_n). The DIScriminator is enabled for approximately ten (10) cycles following the initial current flow through the circuit breaker, provided the load current exceeds approximately 10% of the circuit breaker frame (or current sensor) rating. Should the load current through the circuit breaker drop to less than the 10% value, the release will reset. The release, once reset will remain enabled until the load current passing through the circuit breaker has exceeded the 10% value for 10 cycles. The

DIScriminator will trip the circuit breaker instantaneously, the “OVERRIDE / DIS” LED will light “RED”, and the Display will read “DISC”.

In the event the breaker is not intended to trip out on a circuit whose current could initially be higher than $11 \times I_n$, it is possible to make the DIScriminator inactive.

If a circuit breaker would close onto a high short-circuit current, when the DIScriminator is inactive, type LS or LSG Trip Units will wait for the short-time delay setting before tripping. If the fault current exceeds the short-time withstand current capability of the circuit breaker, the OverRide protection function will trip the breaker without delay. (See Section 1.1.4.) Also, please see Section 1.1.5 for other exceptions when Zone Interlocking is employed.

The DIScriminator (high initial current release) can be made inactive by turning the “OVERRIDE/” setting switch (nearest the bottom edge of the Trip Unit) from the “DIS” position, to the “[blank]” position. (See Figs. 3.2 and 3.5)

Notes: This switch has eight (8) positions, and seven (7) of the positions show “DIS” in the window, ONLY ONE position shows “[blank]”.

When the “OVERRIDE/” window shows “[blank]”, the only fast-acting high short-circuit protection available is the *OVERRIDE* (Fixed Instantaneous). (See Section 1.1.4.)

1.1.4 OVERRIDE (Fixed Instantaneous)

Each Digitrip RMS 610 Trip Unit has a Fixed Instantaneous “Override” analog trip circuit automatically pre-set to a value no greater than the short-time withstand current rating of the circuit breaker in which the Trip Unit is installed. Since the specific values vary for different circuit breaker types and ratings, refer to time-current curves, listed in Section 5, for the values applicable to your breaker. If breaker trips due to high instantaneous current, the “OVERRIDE/” LED will light “RED”, and the display will read “ORID”.

Trip Unit TYPE	RMS DIGITRIP 610						Refer to I.L. Section Number
Catalog Number	S	S	S	S	S	S	
Suffix Number	61	62	63	64	65	66	
Instruction Leaflet No.	I. L. 29-886						
Long-Time Delay Protection							
Adj. Current Setting (Pick-up)	X	X	X	X	X	X	3.2
Adj. Time Delay Setting	X	X	X	X	X	X	3.3
Long Time Memory	X	X	X	X	X	X	3.3
High Load Alarm							
ALARM Indication at Trip Unit	X	X	X	X	X	X	Table 3
Remote ALARM Signal Contacts	X	X	X	X	X	X	1.3
Short-Time Delay Protection							
Adj. Current Setting (Pick-up)		X	X		X	X	3.4
Adj. Time Delay Setting		X	X		X	X	3.5
Opt. "I squared T" Curve Shape		X	X		X	X	3.5
Opt. Zone Interlocking		X	X		X	X	1.1.5
Instantaneous Protection							
Adj. Current Setting (Pick-up)	X	X		X	X	X	3.6
DISCRIminator (11 x) IN or OUT			X		X		1.1.3
OverRIDE (> short time current rating)	1	1	1	1	1	1	1.1.4
Neutral Current Protection	n	n	n				1.1.1
Ground Fault Protection							
Adj. Current Setting (Pick-up)				X	X	X	3.8
Adj. Time Delay Setting				X	X	X	3.9
Opt. "I squared T" Curve Shape				X	X	X	3.9
Opt. Zone Interlocking				X	X	X	1.1.5
Ground Fault Time Memory				X	X	X	3.9
Trip Unit Over-Temp. TRIP	X	X	X	X	X	X	1.1
Auto Lock-Out after TRIP	c	c	c	c	c	c	1.1.2
LED Indicators on TRIP Unit:							
Trip Unit Status (OK = Blinking)	X	X	X	X	X	X	1.1.2
Long-Time Delay TRIP	X	X	X	X	X	X	1.1.2
Short-Time Delay TRIP		X	X		X	X	1.1.2
INSTantaneous TRIP	X	X		X	X	X	1.1.2
OverRIDE / DISCRIminator TRIP			X		X	X	1.1.2
Ground Fault TRIP				X	X	X	1.1.2
Rating Plug Back-up Battery Status	X	X	X	X	X	X	4.5
Integral Test Provision	X	X	X	X	X	X	4
POWER / RELAY MODULE							
Output Signal Contacts:	X	X	X	X	X	X	1.4
Long-Time Delay TRIP	X	X	X	X	X	X	1.4
Short-Circuit TRIP (includes any of:)	X	X	X	X	X	X	1.4
*Short-Time Delay TRIP							
*INSTantaneous TRIP							
*OverRIDE / DISCRIminator TRIP							
Ground Fault TRIP				X	X	X	1.4
Neutral Current ALARM	X	X	X				1.4
High Load ALARM	X	X	X	X	X	X	1.4

LEGEND:
 x = Function included for this trip unit
 c = 120 VAC Control Power required to maintain Lockout
 n = Circuit Breaker must be equipped for Neutral Protection
 * = "DISCRIminator" is also called "Making Current Release"
 1 = n/a for Type DS Breakers
 "blank" = Function n/a for this trip unit

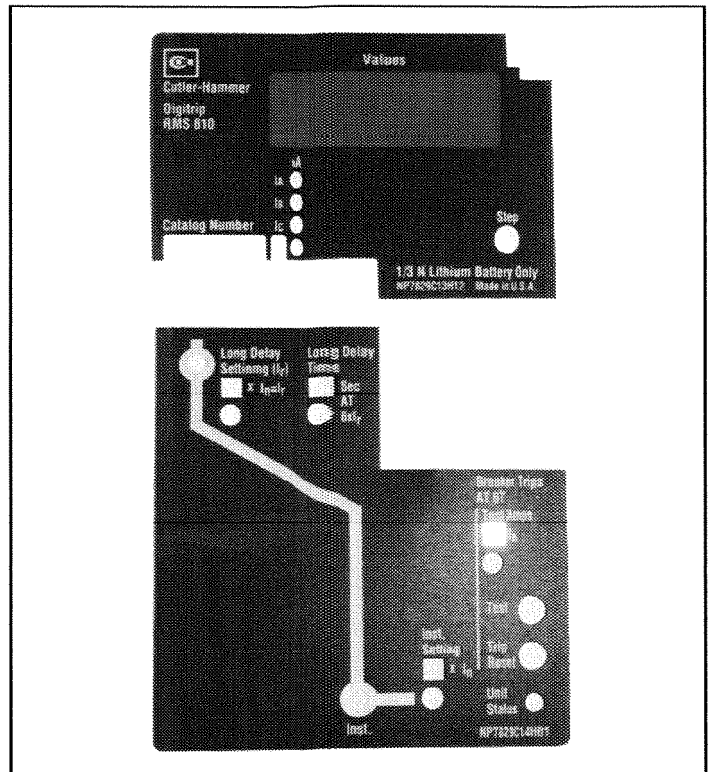

Fig. 3.1 Digitrip RMS 610 Type LI

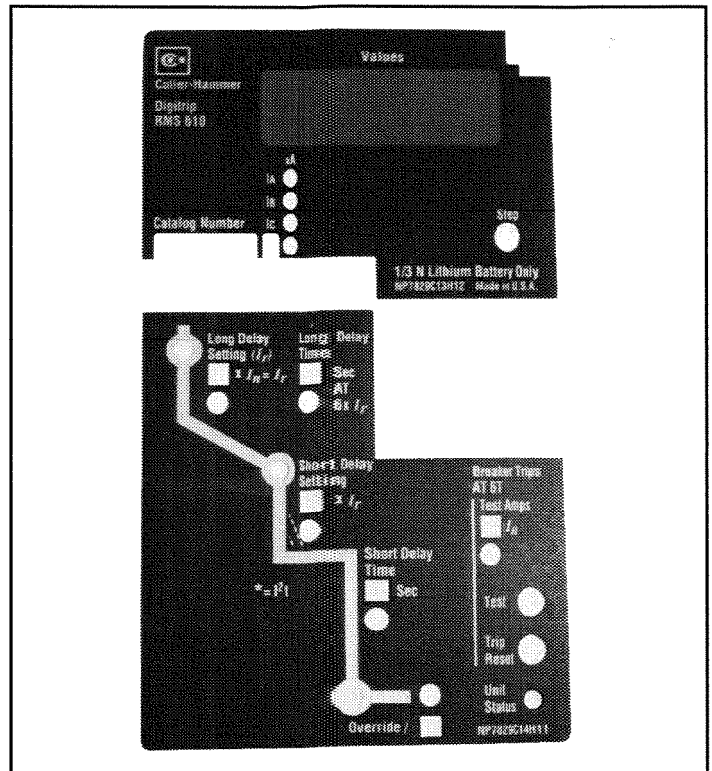

Fig. 3.2 Digitrip RMS 610 Type LS

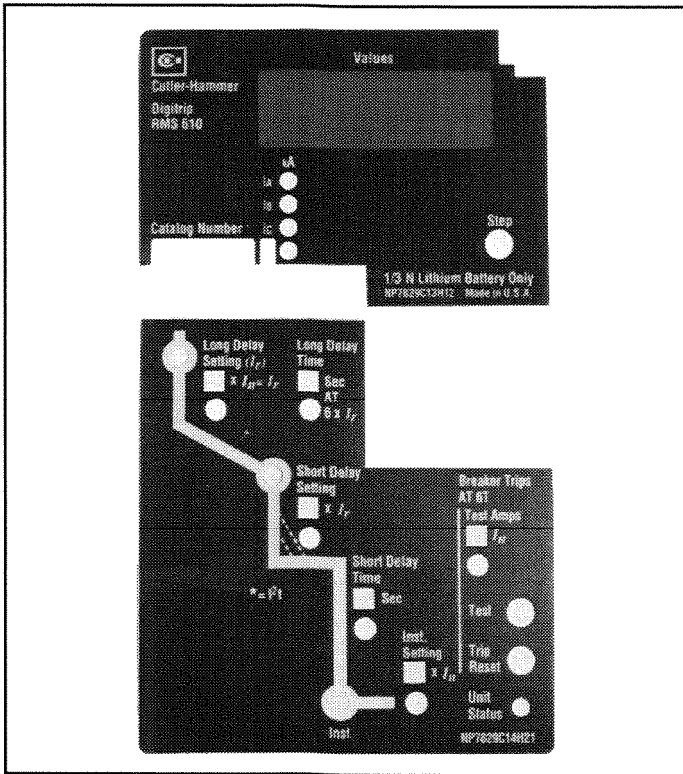

Fig. 3.3 Digitrip RMS 610 Type LSI

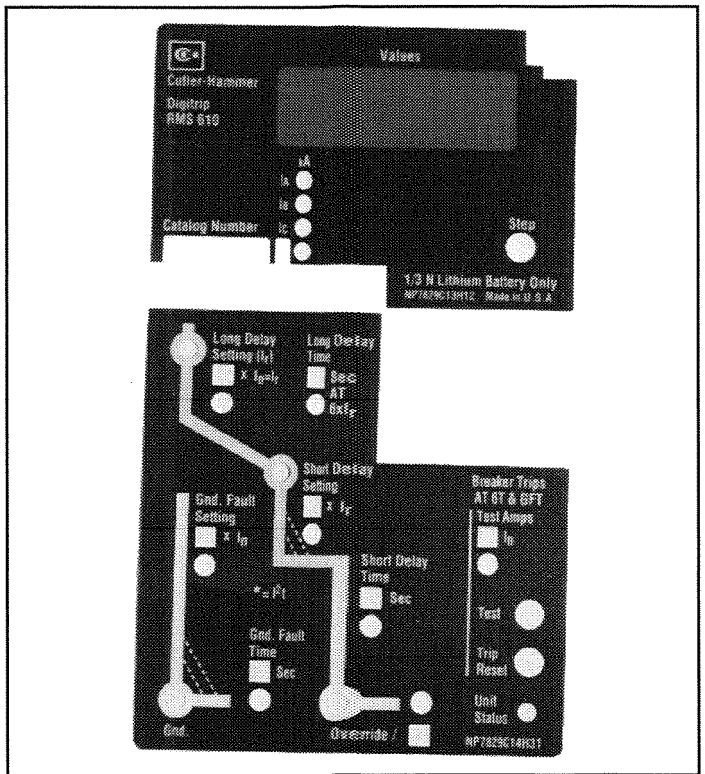

Fig. 3.5 Digitrip RMS 610 Type LSG

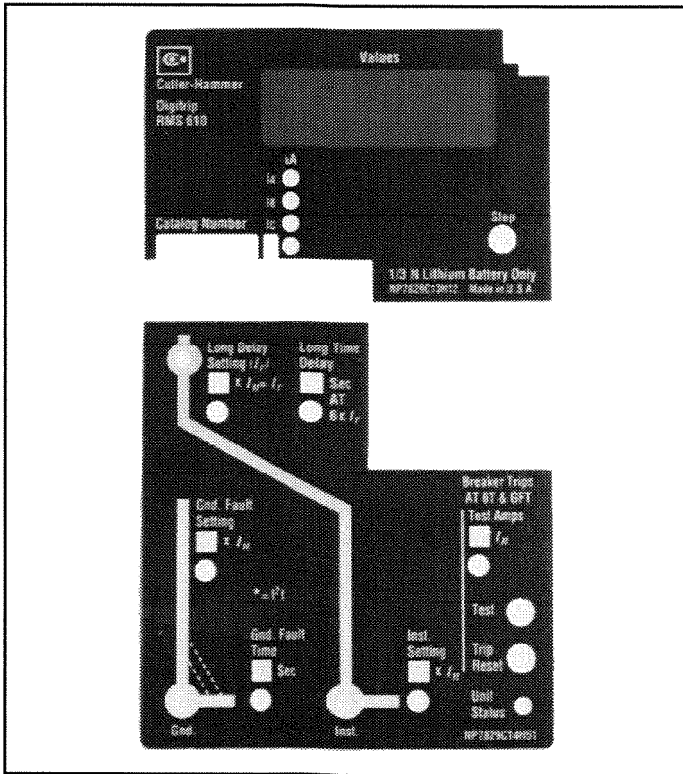

Fig. 3.4 Digitrip RMS 610 Type LIG

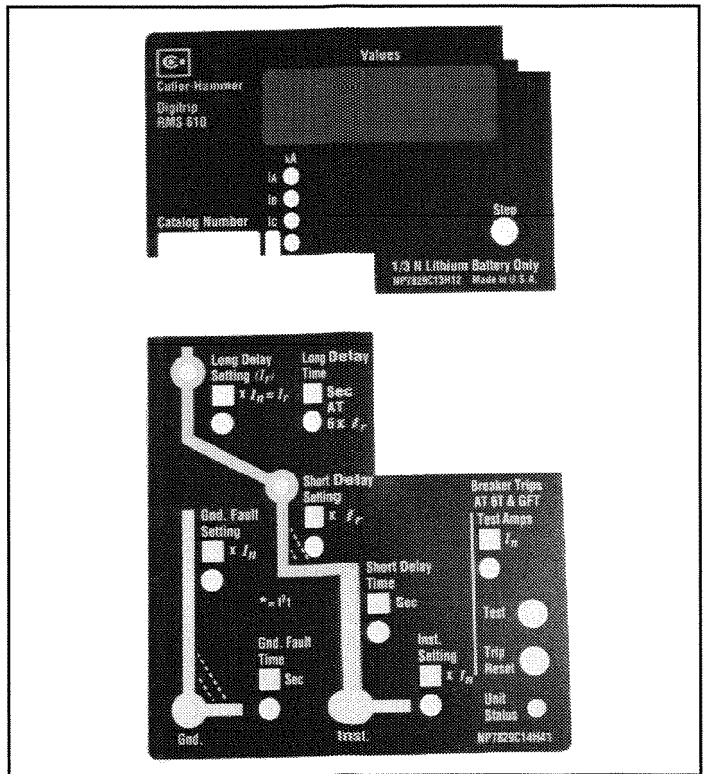

Fig. 3.6 Digitrip RMS 610 Type LSIG

1.1.5 Zone Interlocking

Zone Selective Interlocking (or Zone Interlocking) is available (See Fig. 2) for Digitrip RMS Trip Units having Short Delay and/or Ground Fault protection. Zone Selective Interlocking provides the fastest possible tripping for faults within the breaker's zone of protection, and yet also provides positive coordination among all breakers in the system (mains, ties, feeders and downstream breakers) to limit the outage to the affected part of the system only. When Zone Interlocking is enabled, a fault within the breaker's zone of protection will cause the Trip Unit to:

- Trip the affected breaker instantaneously, and
- Send a signal to upstream RMS Digitrip Trip Units to restrain from tripping immediately. The restraining signal causes the upstream breakers to follow their set coordination times, so that only the minimum service is disrupted, while the fault is cleared in the shortest time possible.

This signal requires only a single pair of wires from the output terminals of the downstream breaker's Trip Unit, to the input terminals of the upstream breaker's Trip Unit. For specific instructions see the applicable connection diagrams for your breaker listed in Section 5.

Note: If a breaker (M) receives a Zone Interlocking signal from another breaker (F) that is tripping, but the fault current level is less than the setting for breaker (M), the presence of the Zone Interlocking signal from the other breaker (F) can not cause breaker (M) to trip.



CAUTION

IF ZONE INTERLOCKING IS NOT TO BE USED (I.E. STANDARD TIME-DELAY COORDINATION ONLY IS INTENDED), THE ZONE INTERLOCKING TERMINALS MUST BE CONNECTED WITH JUMPER WIRES, AS SPECIFIED ON THE CONNECTION DIAGRAMS FOR YOUR BREAKER (SEE SECTION 5), SO THE TIME DELAY SETTINGS WILL PROVIDE THE INTENDED COORDINATION.

For examples of how Zone Selective Interlocking may be used, See Appendix A.

1.2 Four Character Information Display Window

The four-digit alpha-numeric display window, illustrated in Figs. 1 and 2, serves two basic purposes: instrumentation and mode of trip and trouble indication. The information displayed in the window is listed in Tables 2 and 3.

1.2.1 Values Displayed During Normal Service

The alpha-numeric display window provides current values under normal service conditions and coded messages after an alarm condition or after an over-current trip operation. The four "Green" LEDs below the display window indicate which value of current is being displayed. The value in the display window indicates the present value of the parameter whose LED is lighted "Green". In Fig. 1, the four "Green" LEDs identify which current (kA) value is being displayed, i.e. phase A current (I_A), phase B current (I_B), phase C current (I_C), ground current (I_G), or current in the fourth pole (neutral) (I_D). During the normal service conditions, with the circuit breaker closed, the Digitrip 610 serves as an ammeter, displaying the individual phase currents (I_A , I_B , I_C) and ground current (I_G) or the fourth pole (neutral) current (I_D), provided the circuit breaker is set up for ground or fourth pole protection. Current values are displayed in kA. The value displayed is current in the pole (or ground) indicated by the "Green" LED that is turned "On". Press and release the (Black) "STEP" push-button to view the values of current in the other phases. (See Fig. 1.) The range, accuracy and wave shape parameters for current values displayed are:

RANGE: 5% to 100% of Frame Rating for Series C[®]
R-Frame or Type SPB circuit breakers,
or 5% to 100% of [Current] Sensor Rating for
Type DS circuit breakers.

ACCURACY: ± 2% of Frame Rating for Series C[®]
R-Frame or Type SPB circuit breakers,
or ± 2% of [Current] Sensor Rating for
Type DS circuit breakers.

WAVE SHAPE: Sinusoidal, ref. IEC 947-2 Appendix F
(Harmonic content included for True RMS reading)

1.2.2 Messages Displayed After ALARM or TRIP

After an ALARM condition or circuit breaker TRIP operation occurs, one of the coded messages listed in Table 3 will appear in the display window, provided control power is still available for the Power/Relay Module (See Section 1.4). When an ALARM condition occurs, the operator has time to take action, such as reducing the load, to correct the situation. The message will remain in the display window until the "STEP" push-button (See Fig. 1) is pressed and released, then the message will disappear and the values of currents (kA) at the present time can be viewed in the window.

Note: Press and release the “STEP” push button several times to be sure you see the values of all the currents. The first value you see may not be the greatest.

Following a circuit breaker TRIP operation, the display window indicates the reason for trip, using coded messages such as, INST (Instantaneous Trip), LDT (Long Delay Trip), etc. As with the ALARM function, press and release the “STEP” push button to clear the reason for trip message and the display window will then show the values of current at the time of trip. (See notes (1), (2) and (3) under Table 3.) The values remain in memory, and the “red” reason for Trip LED (See Figs. 1 and 3.1 - 3.6) remains lighted, until the Trip Unit is reset by pressing and releasing the “TRIP RESET” push-button in the lower right corner of the Trip Unit. (See Fig. 1.)

Note: Be sure to RECORD all values of interest, note which “RED” LEDs are lighted, and correct the cause of the overload or fault BEFORE YOU RESET the Trip Unit.

The LOCKOUT after trip feature requires the Trip Unit to be reset before the breaker can be closed again.

For examples of how to interpret the display after an overload and after a short-circuit, see Appendix B.

1.2.2.1 ROM Error...See I.L.

If you see the message, “ROM Error...See I.L.”, scrolling across the display window, it means that a non-fatal error has been detected somewhere in the Trip Unit’s memory. The condition is not serious, and the Trip Unit will still function to protect the circuit, but the published Time-Current Curve tolerances may be exceeded in some cases by as much as 12%. It is not necessary to trip and lock out the breaker; however, the Trip Unit should be replaced at the earliest opportunity. There may also be errors in values of current displayed, and they could be even greater than 12%. The scrolling message will not remain in the window constantly, and you can read present values of parameters at any time by pressing and releasing the “STEP” push button, as you normally would. The message will automatically reappear every few minutes, and further, every time you press and release the “TRIP RESET” push button, the message will also be displayed, to remind you to replace the Trip Unit at your earliest opportunity.

TABLE 2 - DIGITRIP RMS 610 INFORMATION FUNCTIONS

Trip Unit TYPE	RMS DIGITRIP 610						Refer to I.L. Section Number
	S 6 1 L I	S 6 2 L S I	S 6 3 L S I	S 6 4 L S I	S 6 5 L S I	S 6 6 L S I	
Catalog Number							
Suffix Number	61	62	63	64	65	66	
Instruction Leaflet No.	I. L. 29-886						
4 - Character LED Display	X	X	X	X	X	X	1.2
Current Values:							1.2.1.1
Phase A Current [Ia] (kA)	X	X	X	X	X	X	I
Phase B Current [Ib] (kA)	X	X	X	X	X	X	I
Phase C Current [Ic] (kA)	X	X	X	X	X	X	I
Ground Current [Ig] (kA)				X	X	X	I
Neutral Current [Id] (kA)	n	n	n				1.2.1.1
Local Messages:							TABLE 3
DISC = DISCRIminator Trip			X		X		I
GNDT = GrouND Trip				X	X	X	I
HILD = High LoaD Alarm	X	X	X	X	X	X	I
INST = INSTantaneous Trip	X	X	X	X	X	X	I
LDPU = Long-Time Delay Pick-Up	X	X	X	X	X	X	I
LDT = Long-Time Delay Trip	X	X	X	X	X	X	I
ORID = OverRIDe Trip	1	1	1	1	1	1	I
ORNG = OverRaNGe Trip	X	X	X	X	X	X	I
PLUG = Rating PLUG Problem	X	X	X	X	X	X	I
SDT = Short-Time Delay Trip		X	X		X	X	I
TEMP = OverTEMPerature Trip	X	X	X	X	X	X	I
TEST = TEST ready to begin	X	X	X	X	X	X	TABLE 3
LEGEND: X = Function Included n = Circuit Breaker must be equipped for Neutral Protection 1 = n/a for Type DS Breakers							

1.3 Frame Rating, Sensor Rating (where applicable) and Rating Plugs

The **Frame Rating** of a circuit breaker is the maximum RMS current it can carry continuously. The maximum Short-Circuit Current Ratings of the circuit breaker are usually related to the Frame Rating as well.

It is often times desirable to be able to choose a current value (I_n), less than the full frame rating, to be the basis for the coordination of the circuit breaker’s protection functions, without affecting its short-circuit current capability. For the Digitrip RMS 610 Trip Unit the maximum continuous current (I_n) is set by the **Rating Plug** (and/or **Current Sensors**, where applicable)—see Section 5 for specific instructions for your circuit breaker type.

The **(Current) Sensor Rating** (where applicable) is the maximum RMS current the circuit breaker can carry with the specified current sensors installed. The Sensor Rating can be the same or less than the Frame Rating, but not greater.

The **Rating Plug** (See Fig. 4) fits into a special cavity to complete the Trip Unit (See Fig. 1).

TABLE 3 - DIGITRIP RMS 610 TRIP UNIT MESSAGE CODES AND THEIR MEANINGS			
MESSAGE	MEANING	COMMENT	SEC.
DISC	DISCriminator Trip ^① (High Initial Current Release)	Breaker tripped instantaneously because phase current exceeded 11 x rating plug current I_n Value	1.1.3
GNDT	GrouND-fault Trip ^②	Breaker tripped because ground current exceeded Ground Fault protection settings	3.8, 3.9
HILD	HIGH LoaD Alarm ALARM: Nearing Overload Condition	Phase current has exceeded 85% of Long-Time Current Setting for more than 40 seconds	App'x B Case1
INST	INSTantaneous Trip ^③	Breaker tripped instantaneously because phase current exceeded instantaneous protection setting	3.6
LDPU	Long-Time Delay Pick-Up ALARM: Overload Condition in Progress	Phase current has exceeded Long-Time current setting. Trip unit is timing to trip breaker.	3.2
LDT	Long-Time Delay Trip ^④ (Overload Trip)	Breaker tripped because phase current exceeded Long-Time protection settings	3.2, 3.3
ORID	OverRIDE Trip ^⑤	Breaker tripped instantaneously because phase current exceeded short-time rating of circuit breaker	1.1.4
ORNG	Over RaNGe Trip ^⑥ (Current too high to measure.)	Breaker tripped instantaneously because phase current (or ground current) exceeded 28 x rating plug current I_n value.	1.2.2
PLUG	Rating PLUG Problem	Rating Plug is missing, damaged, or not well connected. If breaker is closed, it will trip, and the instantaneous/override LED will light. If breaker is open, it will not close.	1.3
ROM ERROR...	Nonfatal memory error	Protection functions still operate, but may be up to 12% out-of-tolerance. Replace trip unit at first opportunity.	1.2.2.1
SDT	Short-Time Delay Trip ^④	Breaker tripped because phase current exceeded Short-Time Delay protection settings	3.4, 3.5
TEMP	OverTEMPerature Trip	Breaker tripped because ambient temperature of SURE+™ chip exceeded 95 degrees C	1.1
TEST	TEST and trip breaker is ready to begin	Trip Unit test will begin as soon as you release the push to test button and "TEST" message will disappear. The breaker will trip, and the cause of trip is displayed.	4.0
[blank]	Test (without tripping breaker) is ready to begin or Trip unit not "ON"	Trip Unit test will begin as soon as you release push to test button, and the display shows the elapsed time of test. Control power is out.	4.0

NOTES:

- ① In the case of a high-level fault condition where fast tripping is desirable, the Trip Unit will operate before a complete RMS current value can be calculated. For this reason, the displayed value may be less than the actual RMS fault current.
- ② In the case of a very high fault current (greater than 28 x I_n), the message "ORNG" (indicating over range) appears because the Trip Unit cannot determine the actual value of the fault current.
- ③ OverRide (Fixed Instantaneous) Trip is for type LS and LSG Trip Units (no Instantaneous element), on circuit breakers whose Short-Circuit current interrupting capability exceeds their Short-Time Current withstand capability. (See Section 1.1.4)
- ④ The values of the currents displayed after a TRIP event, are the values at the time the TRIP operation was initiated. Although the magnitude of a fault current, for example, can continue to increase after the TRIP operation is initiated, those values of current occurring after the TRIP operation is initiated, are not displayed.



CAUTION

BEFORE YOU FIT THE RATING PLUG INTO THE TRIP UNIT, BE SURE TO CHECK THAT THE BREAKER TYPE AND FRAME RATING (OR SENSOR RATING IF APPLICABLE), MATCH THOSE PRINTED ON THE RATING PLUG COVER. INSTALLING A RATING PLUG THAT DOES NOT MATCH THE BREAKER TYPE AND FRAME RATING (OR SENSOR RATING, IF APPLICABLE), CAN PRODUCE SERIOUS MISCOORDINATION AND/OR FAILURE OF THE PROTECTION SYSTEM

After installing the Rating Plug, press and release the "TRIP RESET" push-button. The purpose of the rating

plug is to set the value of I_n , the basis for the Trip Unit protection function current settings. (See Section 3 for details.) Each circuit breaker frame rating represents the maximum current it can carry continuously. However for proper coordination of over-current protection, it is often desirable to choose different levels of I_n for different circuit breakers of the same frame rating. An assortment of rating plugs with different I_n values is available for each breaker frame rating (See circuit breaker instruction leaflet supplements listed in Section 5) to give the user flexibility to change the value of I_n without having to change the primary current sensors on the breaker. By changing the rating plug, the user can easily change the range of current protection settings without having to remove the circuit breaker from its enclosure.

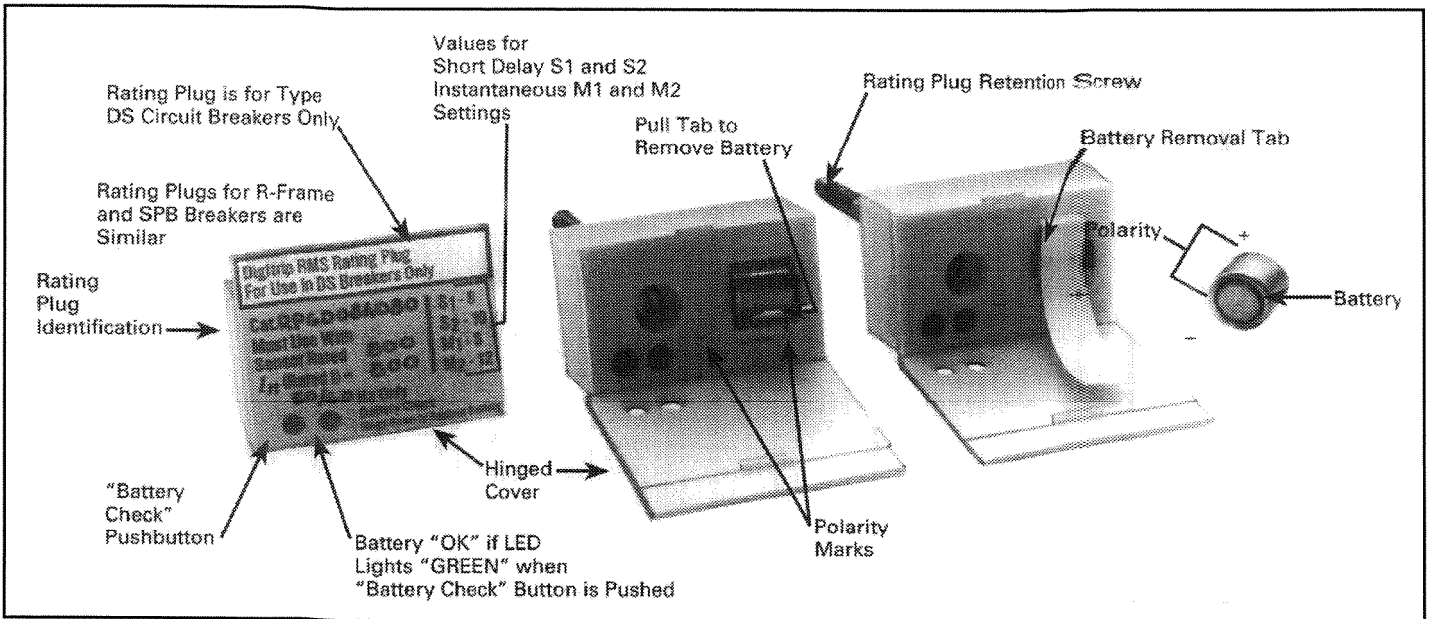

Fig. 4 Rating Plug

For example, if one expects a circuit to carry 600 A initially, but then increase to 1400 A in the future, one could initially install 1600 A cables and a 1600 A breaker frame with the Trip Unit rating plug whose $I_n = 800$ A. Then later on when the additional load is ready to come on line, the rating plug could be exchanged for one with $I_n = 1600$ A, without having to remove the breaker from its enclosure. The available settings would give the following choices:

Long Delay Setting

$$I_r = I_n \times : .5 \quad .6 \quad .7 \quad .8 \quad .85 \quad .9 \quad .95 \quad 1.0$$

Plug $I_n = 800$ A

LDPU $I_r = :400 \quad 480 \quad 560 \quad 640 \quad 680 \quad 720 \quad 760 \quad 800$ A

Plug $I_n = 1600$ A

LDPU $I_r = :800 \quad 960 \quad 1120 \quad 1280 \quad 1360 \quad 1440 \quad 1520 \quad 1600$ A

Note: Rating plugs from Digitrip models 500 / 600 / 700 / 800 CANNOT be used with model 610 Trip Units. The connection pins are located in different positions, so one cannot accidentally use the incorrect type of plug.

Rating Plugs for the Digitrip RMS 610 Trip Units are marked for, and may be applied on both 50 and 60 Hz systems.

Rating plugs have two current ratings listed on their covers (See Fig. 4).

- the "Must Use With Frame Rated" current value (or "Sensor Rated", if applicable),

and

- " I_n (Rated I) =" current value.

This latter value (I_n) is the basis for the Trip Unit current settings:

- The Instantaneous and Ground Current Settings (if applicable) are multiples of (I_n) (See Sections 3.6 and 3.8.)
- The Long Delay Current Setting, I_r , is a multiple of (I_n). Long Delay Current Setting = $I_r = LD \times (I_n)$. (See Section 3.2.)
- The Short Delay Current Setting (if provided) is a multiple of I_r , which in turn is a multiple of (I_n). Short Delay Current Setting = $SD \times I_r = SD \times LD \times (I_n)$ (See Section 3.4.)

If the rating plug is missing or not well connected, then the display will show "PLUG" and the instantaneous / override LED will be lighted. If the circuit breaker is closed, it will trip; if it is open, it will remain trip-free, as long as 120 VAC control power is available to the Power / Relay Module. Even if control power is lost, and the rating plug condition is not corrected, as soon as the three-phase current through the circuit breaker reaches 20% (40% if single-phase current) of the frame / current sensor rating, the Trip Unit will trip the breaker again.

As indicated in Figs. 2 and 4, a back-up battery is provided to maintain the mode of trip LED indication in the Digitrip RMS 610 Trip Unit when external control power to

the Power/Relay module is not available. The back-up battery is located in the rating plug along with a battery check push-button and a green battery check LED. The battery in the rating plug is "OK" if the LED lights "Green" when the "battery check" button next to it is pushed. (See Section 4.5.)

Note: The battery is used only to maintain the cause of TRIP LED indication. It has *no* part in the *protection* function of the Trip Unit, and, it does *not* light the display window.

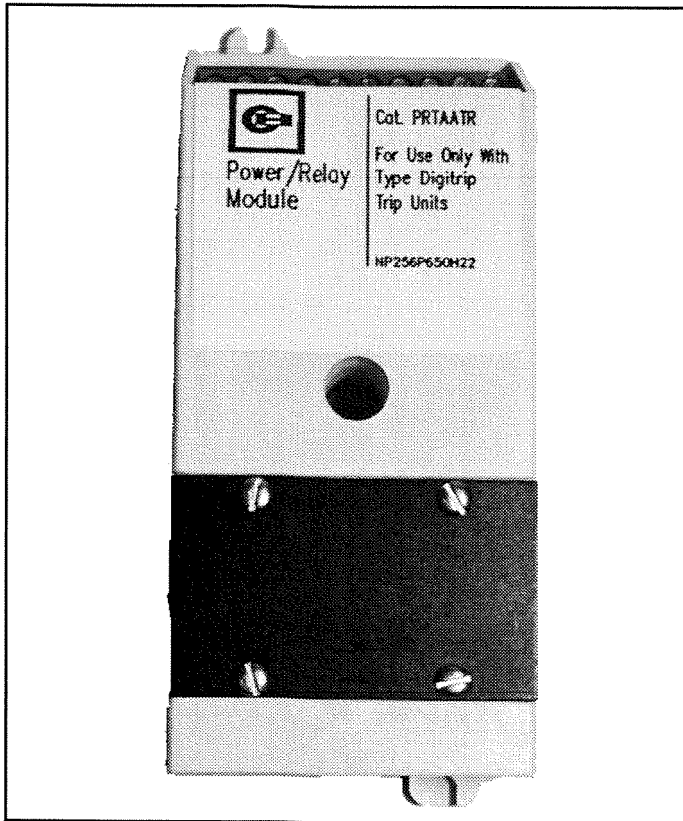

Fig. 5 Power/Relay Module

1.4 Power / Relay Module

The Power / Relay Module (PRM) (see Fig.5) is separate from the RMS Digitrip 610 Trip Unit itself, and is **not required** for the Trip Unit to perform its **protection functions**. The Power / Relay Module performs two functions. First, it uses available external control power (120V 50/60 Hz AC, 6 VA) to operate the display window and reason for trip LED indicators. Second, it has internal signal relays for use by other devices in the control scheme, at locations remote from the circuit breaker. The internal

relays operate when the Trip Unit detects the following conditions:

- Short-Circuit Trip Alarm
- High Load Alarm
- Long Delay Trip Alarm
- Ground Fault Trip Alarm (types LIG, LSG, LSIG) or Neutral Over-Current Alarm (Types LI, LS LSI)

as shown in Fig. 2.

Each relay contact is rated for 120V, 50/60 Hz AC, 1.0 Ampere.

The Short-Circuit Trip Alarm contact operates after the breaker TRIPS due to an INSTantaneous trip, Short-Delay Trip, DISCrminator trip, a Fixed Instantaneous OverRIDE trip, or a Rating PLUG trip as applicable.

The High Load Alarm contact operates after the load current has exceeded 85% of the long delay current setting, I_r , for 40 seconds. The 40-second delay allows the system to "ride through" momentary high load conditions and avoid nuisance alarms.

The Long Delay Trip Alarm contact operates after the breaker TRIPS due to over-load conditions which exceeded the Long Delay Trip settings.

For Type LSG, LIG and LSIG Trip Units, the ground Fault Trip Alarm contact operates after the breaker TRIPS due to conditions which exceed the Ground Fault protection settings. For Type LS, LI, and LSI Trip Units, the Neutral Current Alarm contact operates when the neutral current exceeds the Long Delay Current protection setting, I_r .

Even without available external control power, once the load current through the circuit breaker exceeds approximately 20% (40% if single phase) of the frame/current sensor rating, the green LED will flash "On and Off" once each second, to indicate the Trip Unit is energized and operating properly, and all protection functions are functioning. However, the display window will remain dark.

Note: If 120 VAC control power is lost to the Power/Relay Module, the LOCKOUT after trip will reset and the breaker can be closed again. However the cause of trip bit will remain set in the Digitrip's non volatile memory and a cause of trip message will reappear when control power returns. A complete clearing of cause of trip history may be accomplished by depressing the reset push-button when the Digitrip unit is powered up. (Indicated by the Unit Status flashing)

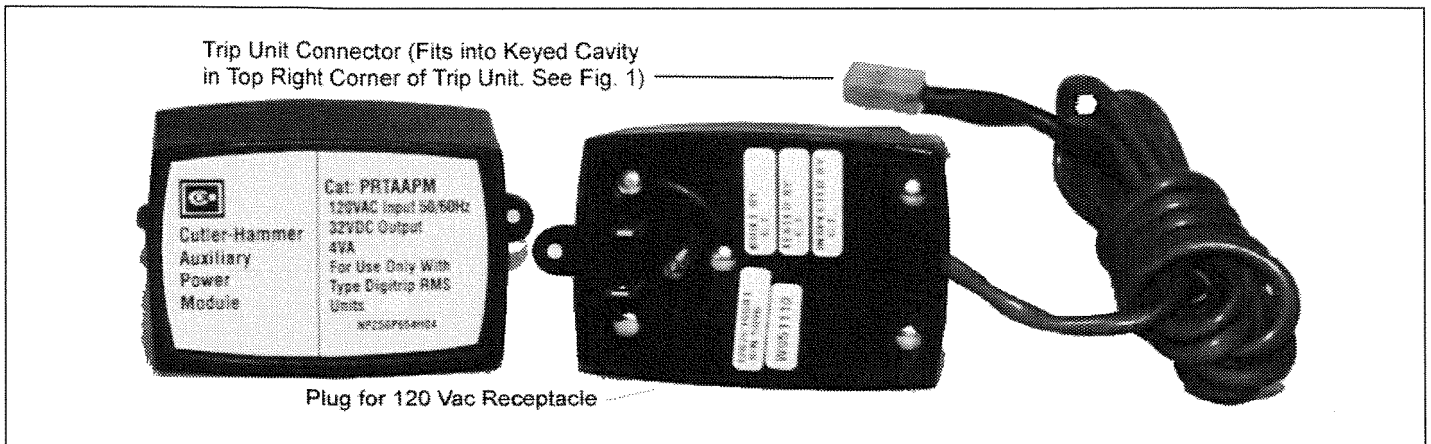

Fig. 7 Auxiliary Power Module

1.5 Auxiliary Power Module

The Auxiliary Power Module or APM (Cat. No. PRTAAPM), illustrated in Fig. 7, is an encapsulated power supply that requires a 120 VAC input at either 50 or 60 Hz. It provides an output of 32 VDC (nominal 40 VDC open circuit) which is used during testing of the Digitrip RMS 610 Trip Unit, whenever 120 VAC control power is not available to the Power/Relay Module. (See Section 1.4.) When a drawout circuit breaker is equipped with a Digitrip RMS 610 Trip Unit, it can be conveniently set and tested while the circuit breaker is either out of its cell or in its cell in the "Test", "Disconnect" or "Withdrawn" positions by using the Auxiliary Power Module.

The Auxiliary Power Module is equipped with a unique plug-in connector suitable only for plugging into the keyed receptacle in the upper right corner of a Digitrip RMS Trip Unit as shown in Fig. 1. This avoids the inadvertent use of an incorrect type power module.

The APM is suitable for use with older Digitrip RMS 500, 600, 700, 800, as well as newer RMS 510, 610 and 810 Models.

2.0 UL LISTED DEVICES

Digitrip RMS 610 Trip Units are "Listed" by the Underwriters Laboratories, Inc.® under UL File E7819, for use in types DS, DSL, SPB and Series C® R-Frame circuit breakers.

3.0 PROTECTION SETTINGS

3.1 General

Prior to placing any circuit breaker in operation, each Trip Unit protection setting must be set to the values specified by the engineer responsible for the installation. The num-

ber of settings that must be made is determined by the protection supplied as illustrated in Figs. 8.1 through 8.7. Each setting is made with a rotary switch, using a small screwdriver. The selected setting for each adjustment appears in its respective rectangular viewing window as illustrated in Fig. 1.

The installed rating plug establishes the maximum continuous current rating (I_n), up to, but not exceeding the Frame Rating of the circuit breaker. Instantaneous and ground current settings are defined in multiples of (I_n).

To illustrate the effect of each protection curve setting, simulated Time-Current curves are pictured on the face of the Trip Unit. The rotary switch used to make each setting is located nearest that portion of the simulated Time-Current curve it controls. Should an automatic "TRIP" occur (as a result of the current exceeding the pre-selected value), the LED in the appropriate segment of the simulated Time-Current curve will light "RED", indicating the reason for the "TRIP".

The available settings, along with the illustrated effect of changing the settings are given in Figs. 8.1 through 8.7.

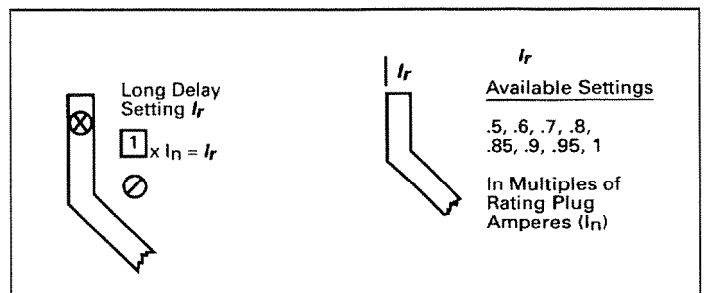

Fig. 8.1 Long Delay Current Settings

3.2 Long Delay Current Setting

There are eight (8) available Long Delay “Pick-up” Current settings, as illustrated in Fig. 8.1. Each setting, called “ I_r ”, is expressed as a multiple (ranging from .5 to 1) of the rating plug current (I_n).

Note: “ I_r ” is also the basis for the Short-Delay Current Setting. (See Section 3.4.)

3.3 Long Delay Time Setting

There are eight (8) available Long Delay Time Settings, as illustrated in Fig. 8.2, ranging from 2 to 24 seconds. These settings are the total clearing times in seconds, when the current value equals six (6) times I_r . The (LS) Time-Current Curve applicable for your circuit breaker gives complete details. (See Section 5.)

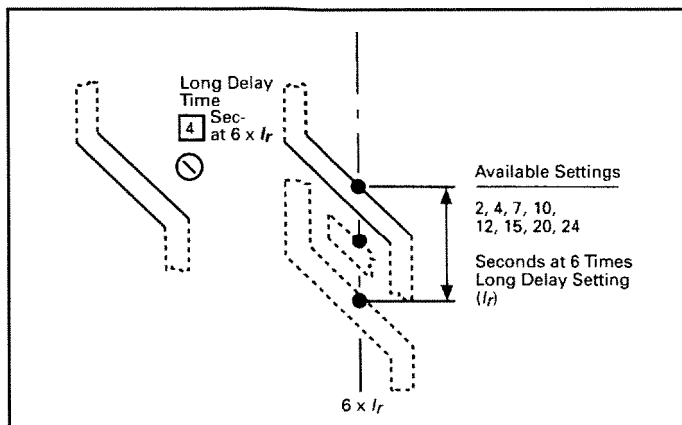

Fig. 8.2 Long Delay Time Settings

Note: In addition to the standard Long Delay Protection Element, the Digitrip RMS 610 Trip Unit also has a Long Time Memory (LTM) function, which serves to protect load circuits from the effects of repeated overload conditions. If a breaker is re-closed soon after a Long Delay Trip, and the current again exceeds the Long Delay Current Setting, I_r , the LTM automatically reduces the time to trip, to allow for the fact that the load circuit temperature is already higher than normal, due to the prior overload condition. Repeated overload conditions can cause the LTM to trip the breaker after a time delay less than the “Long Delay Time setting”. When the load current returns to normal, the LTM begins to reset; and after

about 10 minutes it has reset fully, so that next Long Delay trip time will again be the “Setting” value. To reset the LTM quickly, see Section 4.4, item 3.

3.4 Short Delay Current Setting

There are eight (8) available Short Delay “Pick-up” Current Settings, as illustrated in Fig. 8.3. Six settings are in the range from 2 to 6 times I_r and the other two settings are “S1” or “S2” times I_r . (REMEMBER: I_r is the Long Delay Current Setting). The values that “S1” and “S2” have depend upon the type of circuit breaker, and are specified both on the rating plug label (see Fig. 4) and on the applicable (LS) Time-Current Curve referenced in Section 5.

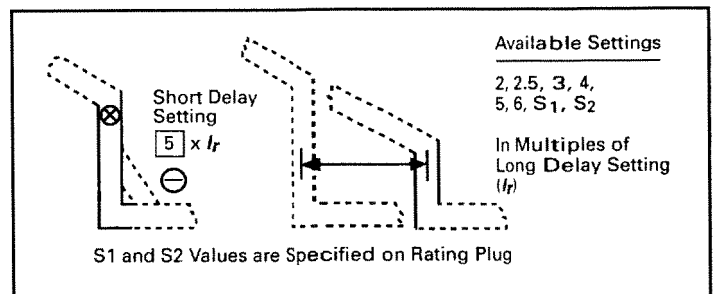

Fig. 8.3 Short Delay Current Settings

3.5 Short Delay Time Setting

As illustrated in Fig. 8.4, there are two different Short Delay curve shapes, i.e., fixed time (flat) and I^2t response. The shape selected depends on the type of selective coordination chosen. The I^2t response will provide a longer time delay in the low-end of the short delay current range than will the flat response.

Five flat (.1, .2, .3, .4, .5 sec.) and three I^2t (.1*, .3*, .5*sec.) response time delay settings are available. The I^2t response settings are identified by the suffix asterisk (*) that appears in the setting viewing window. The I^2t response is applicable to currents less than eight (8) times I_r , the Long Delay setting. For currents greater than 8 times I_r , the I^2t response reverts to the flat response.

Note: See also Section 1.1.5, Zone Interlocking, above.

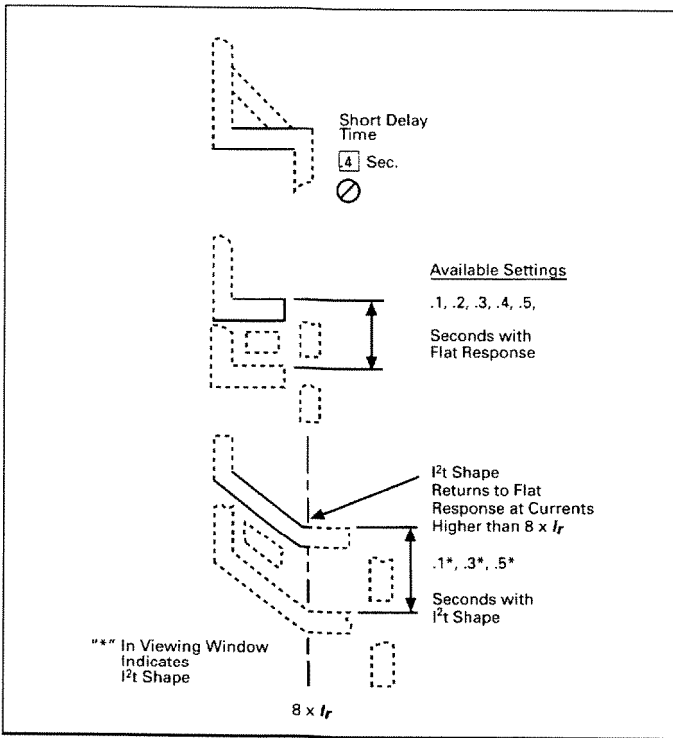

Fig. 8.4 Short Delay Time Settings

3.8 Ground Fault Current Setting

The eight (8) Ground Fault “Pick-up” Current settings are labeled with the code letters “A” through “K” (except there are no “G” or “I” settings), as illustrated in Fig. 8.6. In general, the specific current settings range from 0.25 to 1.0 times (I_n), the rating plug value, but cannot exceed 1200 A. The specific Ground Current Settings for each letter are listed in Table 4 and on the (G) Time-Current Curve applicable for the circuit breaker (see Section 5).

Note: For Testing Purposes Only: When using an external single phase current source to test low level ground fault current settings, it is advisable to use the Auxiliary Power Module (APM) (See Section 1.5 and Fig. 7).

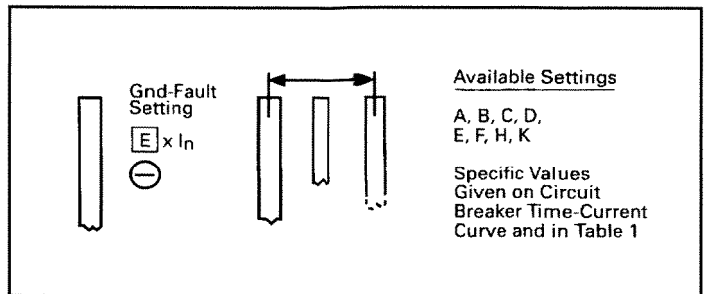

Fig. 8.6 Ground Fault Current Settings

3.6 Instantaneous Current Setting

There are eight (8) available Instantaneous Current Settings, as illustrated in Fig. 8.5. Six settings are in the range from 2 to 6 times the rating plug value (I_n), and the other two settings are “M1” and “M2” times (I_n). The values that “M1” and “M2” have depend upon the type of circuit breaker, and are specified both on the rating plug label (see Fig. 4), and on the applicable (I) Time-Current Curve referenced in Section 5.

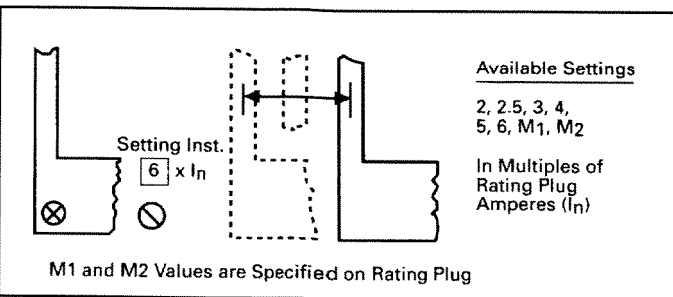

Fig. 8.5 Instantaneous Current Settings

TABLE 4 - GROUND FAULT CURRENT SETTINGS

GROUND FAULT CURRENT SETTINGS (AMPERES)Ⓛ		A	B	C	D	E	F	H	K
INSTALLED RATING PLUG (AMPERES) I _n Ⓜ	100	25	30	35	40	50	60	75	100
	200	50	60	70	80	100	120	150	200
	250	63	75	88	100	125	150	188	250
	300	75	90	105	120	150	180	225	300
	400	100	120	140	160	200	240	300	400
	600	150	180	210	240	300	360	450	600
	630	158	189	221	252	315	378	473	630
	800	200	240	280	320	400	480	600	800
	1000	250	300	350	400	500	600	750	1000
	1200	300	360	420	480	600	720	900	1200
	1250	312	375	438	500	625	750	938	1200
	1600	400	480	560	640	800	960	1200	1200
	2000	500	600	700	800	1000	1200	1200	1200
	2400	600	720	840	960	1200	1200	1200	1200
	2500	625	750	875	1000	1200	1200	1200	1200
	3000/3150	750	900	1050	1200	1200	1200	1200	1200
3200	800	960	1120	1200	1200	1200	1200	1200	
4000	1000	1200	1200	1200	1200	1200	1200	1200	
5000	1200	1200	1200	1200	1200	1200	1200	1200	

Ⓛ Tolerances on settings are ±10% of values shown.
 Ⓜ Refer to Type DS, Type SPB or Series CR-F frame supplemental instruction leaflets given in Section 5 for list of available rating plugs for each type circuit breaker.

3.9 Ground Fault Time Delay Setting

As illustrated in Fig. 8.7, there are two different Ground Fault curve shapes, i.e., fixed time (flat) and I^2t response. The shape selected depends on the type of selective coordination chosen. The I^2t response will provide a longer time delay in the low-end of the ground fault current range than will the flat response.

Five flat (.1, .2, .3, .4, .5 sec.) and three I^2t (.1*, .3*, .5* sec.) response time delay settings are available. The I^2t response settings are identified by the suffix asterisk (*) that appears in the setting viewing window. The I^2t response is applicable to currents less than $0.625 \times I_n$ (The I_n value is marked on the I^2t installed rating plug). For currents greater than $0.625 \times I_n$ the response reverts to the flat response.

Note: See also Section 1.1.5 on Zone Interlocking.

Note: In addition to the standard Ground Fault protection, the Digitrip RMS 610 Trip Unit also has a *Ground Time Memory (GTM)* function, which serves to protect loads in the event of a sputtering arc to ground. Without the *GTM* function, the Trip Unit would normally reset each time the arc sputtered, and begin to time-out all over again, so that a sputtering fault may not have been detected. But with the *GTM* function, the Trip Unit “remembers” the sputtering ground current for up to five (5) times the Ground Fault Time Setting. After that time, it does reset automatically. The *GTM* function does reset rather quickly; on the 0.1 second setting, for example it will reset in 0.5 second.

4.0 TEST PROCEDURES

4.1 General



DANGER

DO NOT ATTEMPT TO INSTALL, TEST OR PERFORM MAINTENANCE ON EQUIPMENT WHILE IT IS ENERGIZED. DEATH OR SEVERE PERSONAL INJURY CAN RESULT FROM CONTACT WITH ENERGIZED EQUIPMENT.

DE-ENERGIZE THE CIRCUIT AND DISCONNECT THE CIRCUIT BREAKER BEFORE PERFORMING MAINTENANCE OR TESTS.

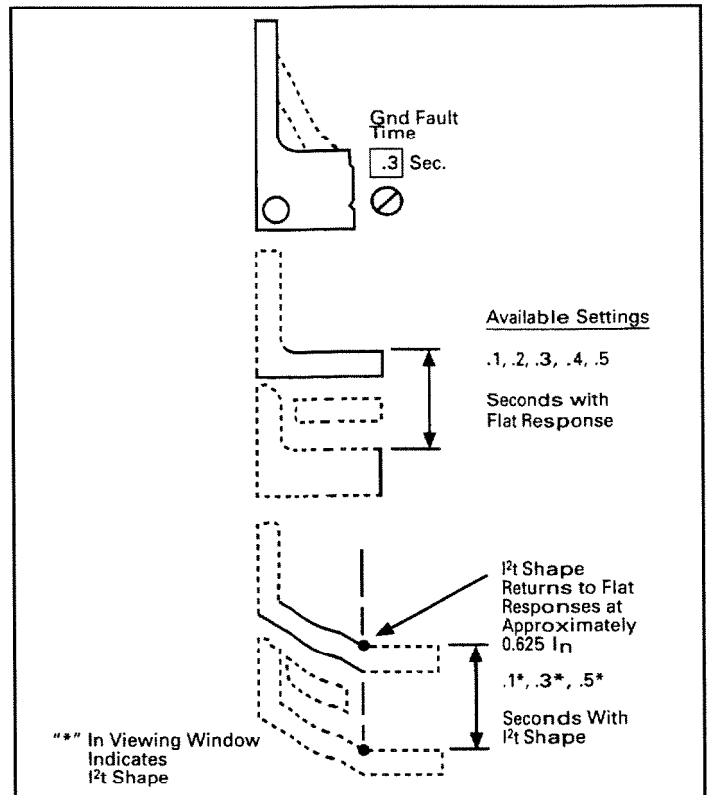

Fig. 8.7 Ground Fault Time Delay Setting

REFER TO THE APPLICABLE CIRCUIT BREAKER INSTRUCTION LEAFLET SUPPLEMENT (LISTED IN SECTION 5) FOR COMPLETE INSTRUCTIONS.



CAUTION

TESTING A CIRCUIT BREAKER UNDER “TRIP CONDITIONS” WHILE IT IS IN SERVICE AND CARRYING LOAD CURRENT, WHETHER DONE BY LOCALLY OR BY REMOTE MEANS, IS **NOT** RECOMMENDED.

ANY TRIPPING OPERATION WILL CAUSE DISRUPTION OF SERVICE AND POSSIBLE PERSONAL INJURY RESULTING FROM UNNECESSARY SWITCHING OF CONNECTED EQUIPMENT.

TESTING OF A CIRCUIT BREAKER THAT RESULTS IN THE TRIPPING OF THE CIRCUIT BREAKER SHOULD BE DONE ONLY WITH THE CIRCUIT BREAKER IN THE “TEST” OR “DISCONNECTED” CELL POSITIONS OR WHILE THE CIRCUIT BREAKER IS ON A TEST BENCH.

4.2 When To Test

Tests can be conducted with the breaker in the “connected” cell position while carrying load current. However, as stated in the caution note in Section 4.1, good practice will limit circuit breaker in-service “trip tests”, where required, to maintenance periods during times of minimum load conditions. Testing is accomplished with the breaker out of its cell or in the “Test”, “Disconnected” or “Withdrawn” (or Removed) cell positions.

Note: Since time-current settings are based on desired system coordination and protection schemes, the protection settings selected and preset in accordance with Section 3 above should not be altered during or as a part of any routine test sequence.

4.3 Testing Provisions

As illustrated in Figs. 1 and 9, an integral test panel is provided to test the Digitrip RMS 610 Trip Unit.

While the Integral Test Panel does enable one to check the performance of many parts of the trip system, including:

- Microprocessor Functions
- Trip Release
- Trip Settings
- LEDs
- Display Panel
- Zone Interlocking Function
- Power Relay Module
- Rating Plug

there are some parts it cannot check, for example:

- Current Sensors
- Auxiliary Current Transformers
- Bridge Circuits
- Calibration Resistors
- Potential Transformer Module
- Analog Override Circuit

and the functions of these elements are best verified by primary current injection testing.

As indicated in Fig. 9, note 1, six different “Test Amps” settings (1, 2, 3, 6T, 8 and 10 x I_n) are available for testing the phase elements of the Trip Unit, and two settings (GF and GFT) are provided for testing the ground element.



CAUTION

A SETTING OF EITHER 6T OR GFT WILL TRIP THE CIRCUIT BREAKER. (SEE SECTIONS 4.1 AND 4.4.2.)

FOR ANY COMBINATION OF THE PHASE PROTECTION SETTINGS, AN APPROPRIATE “NO TRIP” CONDITION CAN BE SET TO TEST THE LONG TIME, SHORT TIME AND INSTANTANEOUS TRIP SETTINGS WITHOUT TRIPPING THE CIRCUIT BREAKER. (SEE SECTION 4.4. 1.)

IN THE “GF” TEST POSITION, THE LEVEL OF TEST CURRENT, BASED ON I_n , IS ADEQUATE TO DEMONSTRATE THE OPERATING CONDITION OF THE TRIP UNIT WITHOUT TRIPPING THE CIRCUIT BREAKER. THIS IS A FUNCTIONAL CHECK ONLY, NOT A CALIBRATION.

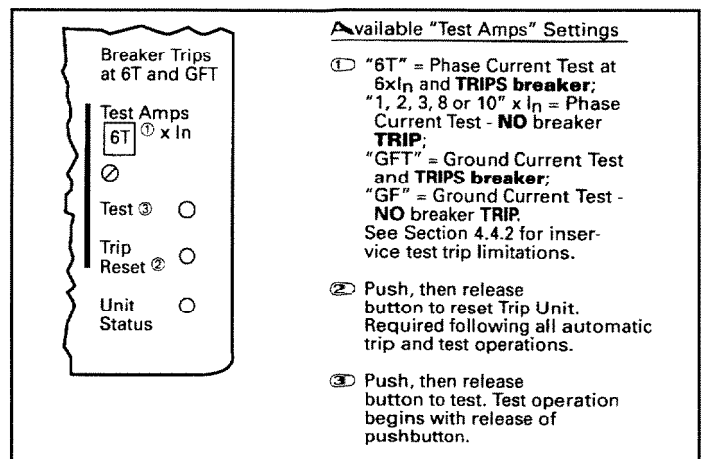

Fig. 9 Integral Test Panel (Lower Right Corner of Trip Unit)

4.4 Conducting Tests

To preserve the primary protection function of the Trip Unit, all in-service testing whether under “Trip” or “No-Trip” conditions is executed **ONLY** if load current values are no greater than $50\% \times I_r$ (I_r = the Long Delay Current Setting). **Any attempt to conduct in-service testing when the load current exceeds 50% of I_r will NOT be executed by the Trip Unit.**

Since the Digitrip RMS 610 Trip Unit is designed to run with control power from the Power / Relay Module for the display window, all testing should be conducted with the control power available, either through the Power Relay Module or, when the breaker is outside the enclosure, through the Auxiliary Power Module (APM) (See Section

1.5 and Fig. 7). Although the Trip Unit is designed to perform all of its Protection Functions without the external control power, and without the display available, results of the tests could be confusing. When performing a single-phase primary current injection test, for example, especially when the single-phase current is low, without the APM it may appear as if the Trip Unit does not respond until the current is well-above the set value, leading the tester to believe there is an error in the Trip Unit when there is none. The reason this occurs is that the single-phase test current is not a good simulation of the normal three-phase circuit. If three-phase current had been flowing, the Trip Unit would actually have performed correctly. Use the APM for correct Trip Unit performance whenever single-phase current injection tests are made.

- 1) **Before starting any test sequence, check the Unit Status (Green LED) in the lower right corner of the Trip Unit (See Figs. 1 and 9) to be sure it is blinking on and off about once each second, which indicates that the Trip Unit is functioning normally.** In the event the Unit Status LED is not blinking, install an Auxiliary Power Module (APM) (See Fig. 7), or if you have already installed one, check to see that it is connected correctly. (See Section 1.5.)
- 2) **If the circuit breaker is carrying current, check that the current is not more than 50% of the Long Delay Current Setting (I_r); because the Trip Unit will not execute your test instructions when it senses that the current through the breaker exceeds the 50% level. If the current through the circuit breaker increases to a value greater than 50% of the Long Delay Current Setting, I_r , the Trip Unit will automatically abort any Trip Unit Test that may be in progress. Should an actual overload or fault condition occur during an in-service, test sequence, the protection function will override the test function, and the circuit breaker will trip automatically in accordance with the actual Time-Current settings.**
- 3) **When performing tests on the Long Delay element, be aware that in addition to the standard protection element, the Digitrip RMS 610 Trip Unit also has a Long Time Memory function (LTM), which serves to protect load circuits from the effects of repeated overload conditions. (See NOTE under section 3.3 Long Delay Time Setting.) The action of the LTM during primary injection tests and during tests initiated from the Trip Unit Test Panel under the "TEST AMPS" setting of "6T", will**

advance the Long Delay Trip Time if multiple Long Delay Time tests are performed repeatedly - as one might do in making single-phase tests on each pole of a breaker in succession, for example. If there is any question, you may simply wait about ten (10) minutes after a Long Delay Trip for the LTM to reset. The LTM is not active during tests initiated from the Trip Unit Test Panel under the "TEST AMPS" settings of "1", "2", "3", "8", or "10".

To reset the LTM immediately:

- Set the "TEST AMPS" to "1".
 - Press and release the (Black) "TEST" push-button (timer will be running in the display window), and then
 - Quickly press and release the "TRIP RESET" push-button before the Trip Unit operates.
 - Now the LTM will be reset.
- 4) **When performing tests on the Ground Fault element, be aware that in addition to the standard protection, the Digitrip RMS 610 Trip Unit also has a Ground Time Memory function (GTM), which serves to protect load circuits from the effects of repeated (sputtering) ground arcs. (See NOTE under Section 3.9 Ground Fault Time Delay Setting.) Because the GTM resets quickly, it will not normally affect ground fault test results, but if Ground Fault tests are repeated quickly, the GTM can make the breaker appear to trip too soon.**

Note: To STOP a TEST initiated via the integral test panel Press and Release the "TRIP RESET" push-button.

4.4.1 Not Tripping the Breaker

1. Place the "TEST AMPS" selector switch (see Fig. 9) in one of the six "No Trip" test settings, i.e., 1, 2, 3, 8, or 10 x I_n , or GF.
2. Press and release the (Black) "TEST" push-button — the test starts when the push-button is released, and the elapsed time will be displayed in the window. When the timer stops, the lighted "RED" cause of trip LED indicates the protection function which operated.
3. Should any of the various protection settings be less than the selected "No Trip" test value, then the LED related to that function will turn on signifying successful completion of the test action. Note: During the long delay tests the Long Delay LED flashes "RED".

4. Reset the Trip Unit by pressing and releasing the "TRIP RESET" push-button; all LEDs lighted by the "No-Trip" test action should turn "OFF", and the display will again show the value of the current through the breaker. In the event that no one resets the Trip Unit after a test, it will wait for about three (3) hours, and then it will automatically revert back to its pre-test status.

4.4.2 Tripping the Breaker



WARNING

CIRCUIT BREAKER OPERATING MECHANISMS OPEN AND CLOSE THE MOVING PARTS VERY FAST, AND WITH VERY HIGH ENERGY. TOUCHING THE MOVING PARTS DURING TEST OPERATIONS CAN CAUSE INJURY. KEEP CLOTHING, HANDS, FEET AND OTHER PARTS OF YOUR BODY WELL AWAY FROM ALL MOVING PARTS DURING TESTING. FOLLOW THE INSTRUCTIONS GIVEN FOR TESTING YOUR SPECIFIC TYPE OF CIRCUIT BREAKER, FOUND IN THE APPROPRIATE INSTRUCTION LEAFLET LISTED IN SECTION 5.

1. Make sure that the circuit breaker is carrying no current. (See **CAUTION** notes under Section 4.1.)

Note: In the event it is decided to perform a "Breaker Trip Test" while load current is flowing, make sure the circuit breaker is carrying no more than 50% of the Long Delay Current Setting I_r . The Trip Unit will NOT execute your instructions to Test itself, when the load current exceeds 50% of I_r .

2. Place the "TEST AMPS" selector switch (See Fig. 9) in either the "6T" (or "GFT") position.
3. Press and release the (Black) "TEST" push-button (See Fig. 9) — the test starts when the push-button is released and the elapsed time is displayed in the window.
4. At least one of the various protection settings will be less than " $6 \times I_n$ ", and the circuit breaker will trip, the LED related to that function will light "RED", and the reason for TRIP code will appear in the display window. (See Table 3 for Code meanings.) If the "STEP" push-button is pressed and released at this point, the "TEST" current value will be shown in

the display window, not the actual current flowing in the breaker.

5. Reset the Trip Unit by pressing and releasing the "Trip Reset" push-button (See Fig. 9). All LEDs lighted by the "Trip" test action should turn "OFF", and the display window will again show the value of current flowing in the breaker.

4.5 Testing the Back-up Battery (Inside the Rating Plug)

The battery has no part in the protection function of the Trip Unit.

The battery is provided only to maintain the "RED" LED indication of the cause of TRIP in the Digitrip RMS 610 Trip Unit, when external control power to the Power/Relay Module is not available. The battery is located in the rating plug along with a battery check push-button and a green battery check LED. (See Fig. 4.)

4.5.1 Back-up Battery Check

The battery is a long life, lithium photo type unit. The status of the battery can be checked at any time. Press and hold the "battery check" push-button and observe the "Green" LED as shown in Fig. 4. If the battery check LED does not light "Green", replace the battery. The condition of the battery has no effect on the protection function of the Trip Unit. Even with the battery removed, the unit will still trip the breaker in accordance with its settings. If however, control power is lost and the battery is dead, the cause of TRIP LED will not be lighted "RED".

4.5.2 Replacing the Back-up Battery

The battery can be easily replaced from the front of the Trip Unit by lowering the hinged cover of the rating plug as shown in Fig. 4. The battery can then be removed by pulling the battery tab as shown in Fig. 4. After the battery is replaced (or after an Auxiliary Power Module is plugged into the Trip Unit), one or more of the cause of Trip LED's may be illuminated. It is necessary to press and release the "TRIP RESET" button to turn off any of the LEDs that may be illuminated. Failure to do so can cause the battery to run down again. The Trip Unit will then be ready to indicate the next cause of trip.

Note: The battery can be replaced at any time, even while the circuit breaker is in service, without affecting the operation of the circuit breaker or its protection function.



CAUTION

CARE SHOULD BE EXERCISED WHEN REPLACING THE BATTERY TO INSURE THAT THE CORRECT POLARITY IS OBSERVED. POLARITY MARKINGS ARE VISIBLE ON THE RATING PLUG WHEN THE HINGED COVER IS OPEN AS INDICATED IN FIG. 4. IF THE BATTERY IS INSERTED WITH INCORRECT POLARITY, AND IF THE 120 VAC CONTROL POWER TO THE POWER RELAY MODULE IS LOST, THEN, AFTER AN OVERCURRENT OR SHORT-CIRCUIT TRIP, NO LEDS WILL BE LIGHTED RED TO INDICATE THE REASON FOR THE TRIP.

The replacement battery should be the same type or equivalent. Acceptable 3.0 volt lithium batteries may be obtained from the following companies under the type designation indicated:

Company	Type
Varta Batteries, Inc. 150 Clarbrook Road Elmsford, NY 10523	CR 1/3N
Duracell South Broadway Tarrytown, NY 10591 (914) 591-7000	DL 1/3N
Sanyo Electric Inc. Battery Div. 200 Riser Road Little Ferry, NJ 07643	CR 1/3N

5.0 REFERENCES

5.1 Digitrip RMS Trip Assemblies

- I.L. 29-885 Instructions for Digitrip RMS 510 Trip Unit
- I.L. 29-886 Instructions for Digitrip RMS 610 Trip Unit
- I.L. 29-888 Instructions for Digitrip RMS 810 Trip Unit

5.2 Type DS Low-Voltage AC Power Circuit Breakers

- I.B. 33-790-1 Instructions for Low-Voltage Power Circuit Breakers Types DS and DSL
- Supplement B Digitrip RMS 510, 610 and 810 Trip Units with to I.B. 32-790-1 Types DS and DSL Low-Voltage Power Circuit Breakers
- AD 32-870 Typical Time-Current Characteristic Curves for Types DS and DSL Circuit Breakers
- SC-5619-93 Instantaneous (I)

- SC-5620-93 Long Delay and Short Delay (LS)
- SC-5621-93 Ground (G)
- 508B508 Connection Diagram for Type DS Circuit Breakers

5.3 Type SPB Systems Pow-R Breakers

- I.L. 29-801 Instruction for the Systems Pow-R Breaker and Drawout Mechanism
- I.L. 29-849 Supplementary Instructions for the Systems Pow-R Breaker used with the Digitrip RMS Trip Units
- AD 29-863 Typical Time-Current Characteristic Curves for Type SPB Systems Pow-R Breaker
 - SC-5623-93 Instantaneous (I)
 - SC-5624-93 Long Delay and Short Delay (LS)
 - SC-5625-93 Ground (G)
- I.S. 15545 SPB Master Connection Diagram

5.4 Series C® R-Frame Molded Case Circuit Breakers

- 29C106 Frame Book
- 29C107 Frame Instruction Leaflet
- 29C713 Supplementary Instructions for Series C® R-Frame used with the Digitrip RMS Trip Units
- AD 29-167R Typical Time-Current Characteristic Curves for R-Frame Circuit Breakers
 - SC-5626-93 Instantaneous (I)
 - SC-5627-93 Long Delay and Short Delay (LS)
 - SC-5628-93 Ground (G)
- I.L. 29C714 Master Connection Diagram for Series C® R-Frame Circuit Breakers

LIST OF FIGURES

Figure	Page
1 Digitrip RMS 610 Trip Unit with Rating Plug	3
2 Digitrip RMS 610 Trip Unit - Block Diagram	3
3.1 Digitrip RMS 610 Trip Unit - Long Delay and Instantaneous Protection.....	5
3.2 Digitrip RMS 610 Trip Unit - Long Delay and Short Delay Protection	5
3.3 Digitrip RMS 610 Trip Unit - Long Delay, Short Delay and Instantaneous Protection.....	6
3.4 Digitrip RMS 610 Trip Unit - Long Delay, Instantaneous and Ground Protection.....	6
3.5 Digitrip RMS 610 Trip Unit - Long Delay, Short Delay and Ground Protection	6
3.6 Digitrip RMS 610 Trip Unit - Long Delay, Short Delay, Instantaneous and Ground Protection	6
4 Rating Plug.....	10

5	Power / Relay Module	11
6	(not used)	
7	Auxiliary Power Module.....	12
8.1	Long Delay Current Settings.....	12
8.2	Long Delay Time Settings.....	13
8.3	Short Delay Current Settings.....	13
8.4	Short Delay Time Settings.....	14
8.5	Instantaneous Current Settings	14
8.6	Ground Fault Current Settings	14
8.7	Ground Fault Time Settings	15
9	Integral Test Panel	16
A.1	Typical Zone Interlocking (Ground Fault Protection).....	21
A.2	Typical Zone Interlocking Connections	21
	(Short Delay Protection)	

LIST OF TABLES

Table	Page	
1	Digitrip RMS 610 Protection Functions	5
2	Digitrip RMS 610 Information Functions	8
3	Trip Unit Message Codes and Their Meanings.....	9
4	Ground Fault Current Settings Codes	14

Appendices	Page	
APPENDIX A	Zone Interlocking - Example	20
APPENDIX B	Interpreting Display Codes after Circuit Breaker Trips - Examples.....	22

APPENDIX A Zone Interlocking

Assume a ground fault of 2000 Amperes occurs and refer to Fig A.1.

CASE 1: There is no Zone Selective Interlocking. (standard time delay coordination is used)

Fault 3

The branch breaker will trip clearing the fault in 0.1 s.

Fault 2

The feeder breaker will trip clearing the fault in 0.3 s.

Fault 1

The breaker will trip clearing the fault in 0.5 s.

CASE 2: There is Zone Selective Interlocking

Fault 3

The branch breaker trip unit will initiate the trip in 0.03 s to clear the fault and Z3 will send an interlocking signal to the Z2 trip unit; and Z2 will send an interlocking signal to Z1 .

Z1 and Z2 trip units will begin to time out, and in the event that the branch breaker Z3 would not clear the fault, the feeder breaker Z2 will clear the fault in 0.3 s (as above). Similarly, in the event that the feeder breaker Z2 would not clear the fault, the main breaker Z1 will clear the fault in 0.5 s (as above).

Fault 2

The feeder breaker trip unit will initiate the trip in 0.03 s to clear the fault; and Z2 will send an interlocking signal to the Z1 trip unit. Z1 trip unit will begin to time out, and in the event that the feeder breaker Z2 would not clear the fault, the main breaker Z1 will clear the fault in 0.5 s (as above).

Fault 1

There are no interlocking signals. The main breaker trip unit will initiate the trip in 0.03 s.

Figure A.2 presents a Zone Selective Interlocking connection diagram for a system with two main breakers from incoming sources and a bus tie breaker. Note the blocking diode D1 is needed so that the feeder breakers can send interlocking signals to both the main and tie breakers, without having the tie breaker send itself an interlocking signal.

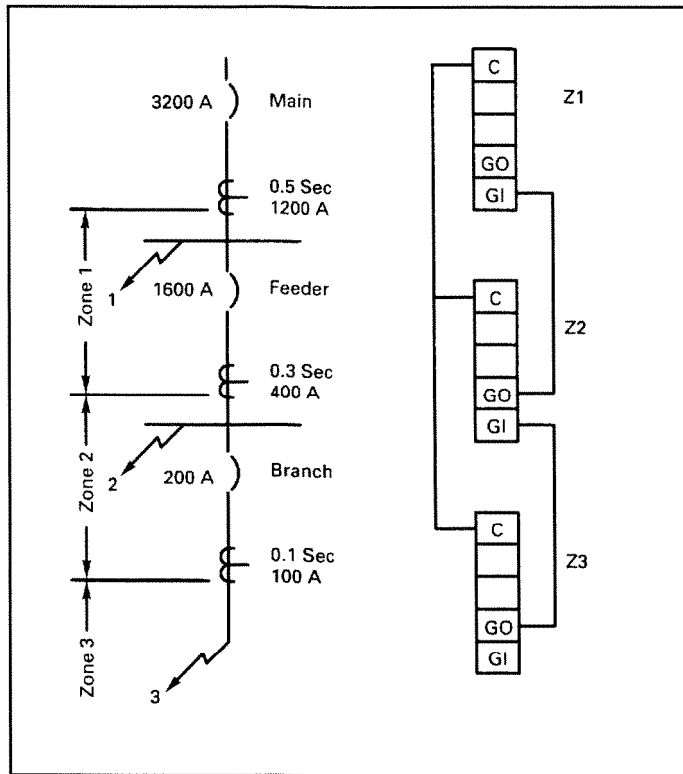

Fig. A.1 Typical Zone Interlocking (Ground Fault Protection)

- NOTES:**
- A1:** Wiring to be twisted pair of AWG No. 14 to AWG No. 20. Route Zone Interlocking wiring separate from power conductors. **DO NOT GROUND** any Zone Interlock Wiring.
 - A2:** The maximum distance between first and last zone is 250 feet (110 m).
 - A3:** A Maximum of 20 breakers may be connected in parallel in one Zone.

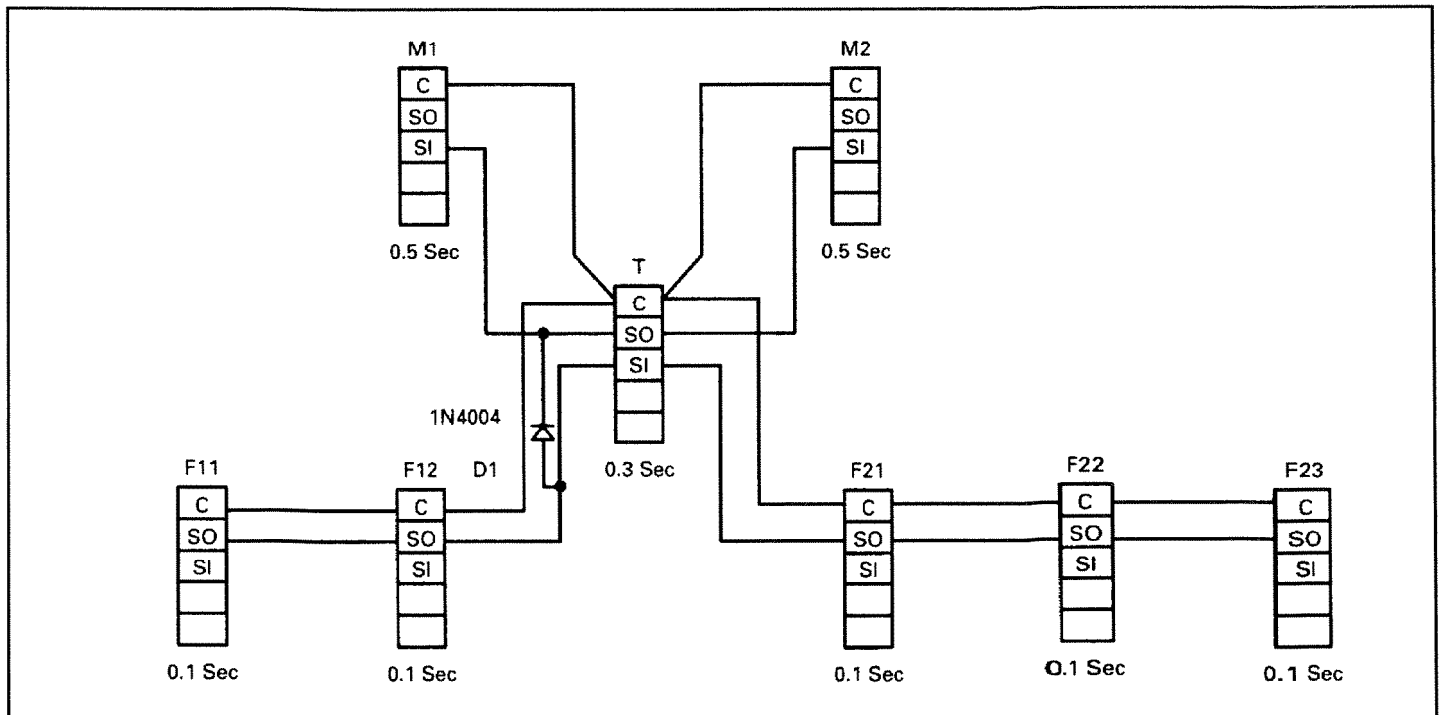
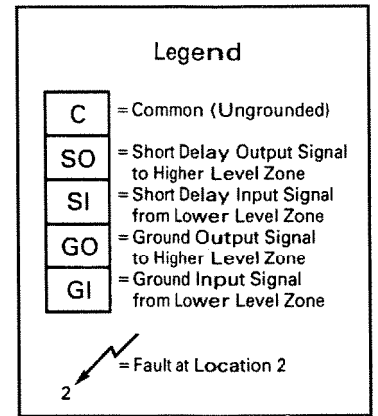

Fig. A.2 Typical Zone Interlocking Connections with Two Main Breakers (M1, M2) and a Tie Breaker (T) (Short Delay Protection)

APPENDIX B Interpreting Display Codes After Circuit Breaker Trips

Given a 1600 A frame circuit breaker with an $I_n = 1000$ A rating plug installed.

CASE 1 - Overload Trip Operation and High Load Condition

Long Delay Current (Pick-up) setting = 1.0, $I_r = 1000$ A

Assume a prolonged 1500A overload condition which results in an automatic breaker trip operation. The following will occur:

- The Long Delay Trip LED will turn "On" (see Fig. 1).
- The coded message "LDT" will appear in the Display Window (see Fig. 1).
- The Long Delay Relay in the Power / Relay Module (see Figs. 2 and 5) will operate to close the remote Long Delay Trip Alarm Contact.

Operator Actions:

1. Observe the mode of trip LED and coded message in the Display Window.
2. Press and release "STEP" push-button (see Fig. 1). This will clear the coded cause of trip message in the Display Window.
3. View values of phase currents in Display Window (see Fig. 1) e.g., 1.50 kA.

Note: The phase current shown will be that identified by the "green" LED (see Fig. 1) that is turned "On", assume " I_A ". (It may not be the faulted phase.)

4. Press and release the "STEP" push-button to view current values similar to " I_A ", " I_B ", " I_C ", " I_G " and " I_D ". Each value of phase current kA appearing in the Display Window, is the value at the time of the trip operation.
5. **RECORD** all Values of interest; note which "RED" LEDs are lighted **BEFORE** resetting the Trip Unit.
6. Reset the Trip Unit by pressing and releasing the "Trip Reset" push-button (lower right corner of Trip Unit, see Fig. 1). All coded messages and/or current values in the display window and the cause of trip LED will turn "Off", and the Remote Alarm contacts in the Power / Relay Module will be reset (open).



NOTICE

FOLLOWING LDT TRIP OPERATIONS, IT IS ESSENTIAL THAT ANY CAUSE OF OVERLOAD TRIP BE CORRECTED PRIOR TO RECLOSING THE CIRCUIT BREAKER. SHOULD IT NOT BE CORRECTED AND THE CIRCUIT BREAKER BE RE-CLOSED TOO QUICKLY, THEN BECAUSE OF THE INHERENT LONG TIME MEMORY FUNCTION (SEE NOTE IN SECTION 3.3), THE LONG DELAY TRIP ELEMENT WILL OPERATE FASTER THAN THE RELATED TIME-CURRENT CURVE INDICATES.

THE AMOUNT OF TIME REQUIRED TO CLEAR THE LTM MEMORY CIRCUIT IS A FUNCTION OF THE LONG DELAY TIME SETTING (SEE FIG. 3.3). THE LONGER THE DELAY SETTING, THE LONGER THE TIME REQUIRED TO RESET THE MEMORY. TOTAL MEMORY CLEARING TIME COULD BE UP TO TWELVE (12) MINUTES. THE LTM CAN BE RESET QUICKLY AS DESCRIBED IN SECTION 4.4 (3).

The LTM memory function, simulates the conventional thermal type (bi-metal) circuit breaker Trip Unit, and serves a useful function by allowing the load conductors to cool down after an overload condition.

7. After correcting the cause of the overload trip (LDT), allow for the LTM memory circuit to reset and reclose the circuit breaker to restore power to the load circuit.

Note: As the current approached the overload condition, prior to the overload trip operation, the following Trip Unit indications would have been visible.

- The "HILD" message would begin to flash in the window when the overload condition had exceeded $0.85 \times I_r$ for 40 seconds or longer. To clear the "HILD" message and to view the present magnitudes of the currents, press and release the (Black) "STEP" push button on the display panel. Remember to push the "STEP" button several times to be sure you see values of currents in all phases, and ground / neutral as applicable.
- The "High-Load" Relay in the Power / Relay Module (see Figs. 2, 5 and Section 1.4) would have been picked up (after a 40-second delay), to close the remote High Load Alarm Contact. Press and release the "TRIP RESET" push button to reset the High Load Relay Contact.

- The Long Delay LED (Fig. 1) begins to flash “On” and “Off”.
- The message “LDPU” begins to flash in the display window when the current value exceeds I_r .

CASE 2 - Instantaneous Trip Operation

Instantaneous Current (Pick-up) setting = $8 \times I_n = 8000 \text{ A}$

Assume a 12 kA fault occurs.

Following the TRIP operation, the following will occur:

- The Instantaneous Trip LED will turn “On” (see Fig. 1).
- The coded message “INST” will appear in the Display Window (see Fig. 1).
- The Short-Circuit Relay in the Power / Relay Module (see Figs. 2, 5 and Section 1.4) will operate to close the Remote Short-Circuit Trip Alarm contact.

Operator Actions:

1. Observe the mode of trip LED and the “INST” message in the Display Window.
2. Press and release the “STEP” push-button to view current values “ I_A ”, “ I_B ”, “ I_C ” and “ I_G ” or “ I_D ” in the display window.

Note: The phase current value displayed will be that identified by the “green” LED (see Fig. 1) that is turned “On”. (But, the first value you see may not be the faulted phase.)

Each value of phase current appearing in the Display Window, is the value at the time the trip operation was initiated.

3. **RECORD** all Values of interest; note **which “RED” LEDs** are lighted **BEFORE** resetting the Trip Unit.
4. The value of one phase current in display window (see Fig. 1) will have been the 12.0 kA fault level.

NOTE: Had the level of the fault current been more than $28 \times I_n$ (or 28 kA in this example) when the reason for trip message would be cleared (by pushing the “STEP” button), instead of the numerical value of current in kA, the “ORNG” code is displayed to show the current level exceeded maximum range of current sensor accuracy.

5. After making sure you have a record of all pertinent information stored in the Trip Unit memory, reset the Trip Unit by pressing and releasing the “Trip Reset” push-button (Lower right corner of the Trip Unit, see Fig. 1.). All coded messages, values of current in the display window memory, and cause of trip LEDs will turn “OFF” while the Remote Alarm Contacts of the signal relay in the Power/ Relay Module will reset (open).
6. Following any corrective actions and / or inspections of the circuit breaker and related equipment, re-close the circuit breaker to restore power to the load circuit.

This instruction booklet is published solely for information purposes and should not be considered all inclusive. If further information is required, you should consult Eaton.

Sale of product shown in this literature is subject to terms and conditions outlined in appropriate Eaton. selling policies or other contractual agreement between the parties. This literature is not intended to and does not enlarge or add to any such contract. The sole source governing the rights and remedies of any purchaser of this equipment is the contract between the purchaser and Eaton.

NO WARRANTIES, EXPRESSED OR IMPLIED, INCLUDING WARRANTIES OF FITNESS FOR A PARTICULAR PURPOSE OR MERCHANTABILITY, OR WARRANTIES ARISING FROM COURSE OF DEALING OR USAGE OF TRADE, ARE MADE REGARDING THE INFORMATION, RECOMMENDATIONS AND DESCRIPTIONS CONTAINED HEREIN. In no event will Cutler-Hammer Inc. be responsible to the purchaser or user in contract, in tort (including negligence), strict liability or otherwise for any special, indirect, incidental or consequential damage or loss whatsoever, including but not limited to damage or loss of use of equipment, plant or power system, cost of capital, loss of power, additional expenses in the use of existing power facilities, or claims against the purchaser or user by its customers resulting from the use of the information, recommendations and description contained herein.

Eaton

Pittsburgh, Pennsylvania, U.S.A.

Style No. 7829C36H02 Effective 5/97
Printed in U.S.A./CCI

EATON