

# INSTALLATION INSTRUCTIONS

UL 1449 4<sup>th</sup> Edition four-pole, high SCCR UL Type 1 surge protective device for 5 wire systems

Effective May 2018

**BUSSMANN**  
SERIES



**⚠ DANGER**

**Hazardous Voltage**  
**Will cause severe injury or death.**  
Working on or near energized circuits poses a serious risk of electrical shock. De-energize all circuits before installing or servicing this equipment and follow all prescribed safety procedures.

Technical data	BSPMA4208WYNGR	BSPMA4480WYNGR
Nominal voltage (VAC)	120 / 208	277 / 480
MCOV [L-N/L-G] [N-G/L-L]	180 V / 360 V 180 V / 360 V	385 V / 565 V 180 V / 770 V
Number of poles	4	4
Number of wires	5	5
Nominal discharge current (I <sub>n</sub> )	20 kA	20 kA
Max. Discharge Current (I <sub>max</sub> )	50 kA	50 kA
SCCR (rms symmetrical amps)	200 kA	200 kA
Frequency	50 / 60 Hz	50/60 Hz
Voltage Protection Rating [L-N/L-G] [N-G/L-L]	0.6 kV / 1.2 kV 0.6 kV / 1.2 kV	1.2 kV / 1.8 kV 0.6 kV / 2.5 kV
Replacement module	BPMA180UL	BPMA385UL / BPMA180UL*
IP rating	IP 20	
Maximum Ambient Temperature	+85° C	
Dimensions in (mm)	H: 3.54 (90), W: 2.83 (72), D: 2.6 (66)	
Weight oz (kg)	15.6 (0.443) / 15.7 (0.445)	
Enclosure material / flammability rating	Thermoplastic, UL 94 V-0 grey	
Mounting method	35 mm DIN-Rail per EN 60715	
Application	UL Type 1 Open Type SPD / CSA Type 1 SPD assembly	
Agency information	ANSI UL 1449 4 <sup>th</sup> Edition / CSA C22.2 No. 269.1, CSA C22.2 No. 269.4	

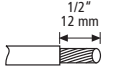
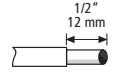
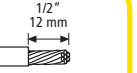
Cu Conductors			
min. □ L, N, G, ⊥	2.5 mm <sup>2</sup> / 14 AWG		
max. □ L, N, G, ⊥	25 mm <sup>2</sup> / 4 AWG	35 mm <sup>2</sup> / 2 AWG	

**Mounting** Phillips head driver  
Torque to 4 N·m / 35 Lbs-in

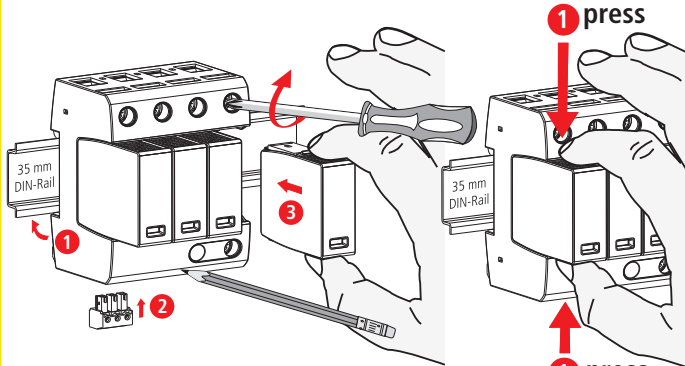

**System installation** Torque to 0.2 N·m / 1.8 lbs-in

**Module replacement**

**Mounting**

**Green = OK**  
**Red = replace**

Visual fault indication status

**Fault indication and remote contact signaling**

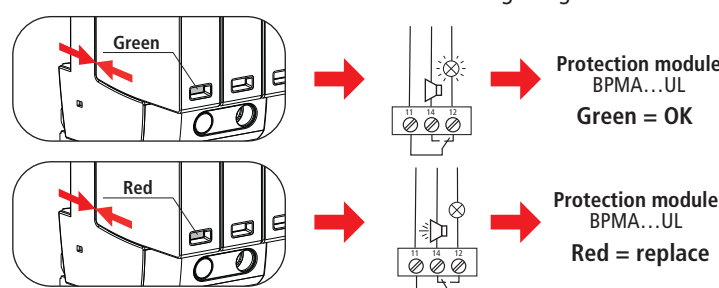

**Testing remote contact signaling (with modules removed)**

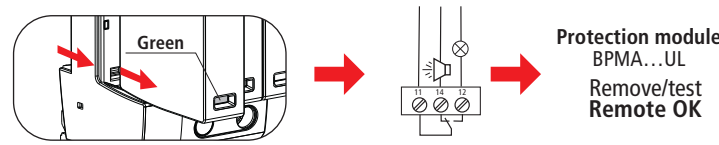

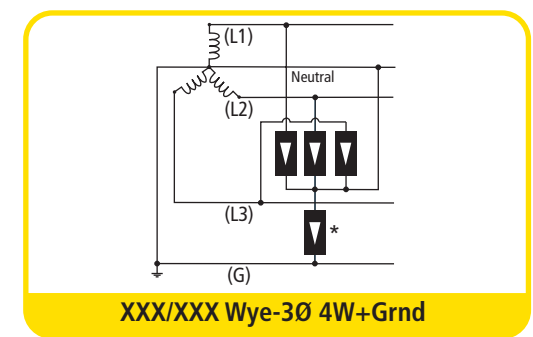
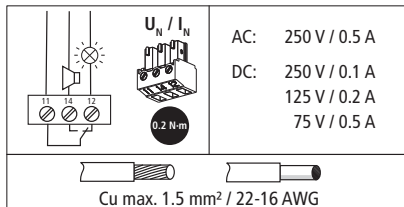

**Fault indication**

AC: 250 V / 0.5 A  
DC: 250 V / 0.1 A  
125 V / 0.2 A  
75 V / 0.5 A

Cu max. 1.5 mm<sup>2</sup> / 22-16 AWG

The remote status indicator (SPDT contact) shall be connected to NEC Class II circuits only!

 = Audio Alarm/Alert  
 = PLC / monitoring system connection

**Remote contact signaling**

## 1. Application of the Bussman™ series XXXX

This modular Surge Protective Device (SPD), sets new standards in terms of safety and user-friendliness, and is designed to protect against transient overvoltages generated by distant lightning strikes or localized switching surges. Typical installations would be inside equipment or industrial control panels associated with specific electrical equipment such as PLCs, drives or other sensitive equipment. This UL Listed SPD features heavy-duty zinc oxide varistors in combination with the dual “Thermo Dynamic Control” monitoring device to help ensure reliable surge protection.

Main device features show that both SPD safety and reliability are key elements.

The locking arrester module is keyed to prevent incorrect replacement and will not release from its socket due to vibration, mechanical shock or electromotive forces.

Nevertheless, modules are easily replaced without tools by simply pressing the module release buttons for easy and safe replacement during its lifetime.

As with all Bussmann series surge protective devices with “Thermo Dynamic Control” evaluation is based on the discharge current intensity and the surface temperature of the heavy-duty varistor.

The visual indicator on each module shows if the module is providing protection (green) or needs replacement (red). In addition to this visual status indication,

included in the Bussmann series XXXX device is a set of isolated Form C (SPDT) contacts for remote signaling. With its isolated Form C contact, the remote signal can be used as a make or break contact according to the particular circuit concept. The surge protective device features multifunctional terminals on a standardized spacing of 1 module for the connection of conductors, allowing easy wiring with other DIN-Rail mounted devices.

## 2. Safety instructions

Warning: Risk of Electric Shock – Deenergize equipment, perform lockout/tagout and follow all prevailing safety procedures during installation and servicing that’s to be performed only by qualified personnel.

Attention: Risque de choc.

Suitable for use on a circuit capable of delivering not more than 200 kA rms symmetrical amperes.

Convient à des circuits produisant au plus 200 kA eff.

The SPD is intended for installation within a NEMA Type 1 enclosure as a minimum in accordance with the National Electrical Code, ANSI/NFPA 70.

- The Bussmann series XXXX SPD is to be installed only by qualified personnel and to be done so in compliance with all applicable local and National Electrical Code requirements.
- For proper system protection and safety, coordination with other SPDs within the facility must be considered. If in doubt, contact our application engineer for assistance by email (FuseTech@eaton.com) or toll free 855-287-7626, Monday – Friday, 7:00 am – 5:00 pm Central Time.
- Installation and connection to service must be done only when the system is de-energized.
- The surge protective device’s installation is to be compliant with its ratings and therefore must not be installed in a more severe environment subjecting it to higher or lower system voltages, currents or energy levels than for which its technical specifications provide.

## 3. General installation instructions

Sections 250 and 285 of the NEC (NFPA 70) and the IEEE Green Book-Std. 142 should be consulted. Local electrical codes and/or the Canadian Electrical code also have to be considered.

**System voltage:** Make sure that the SPD is correctly rated for the system where the SPD is applied. The maximum continuous operating voltage (MCOV) must not be exceeded.

**Mounting:** Make sure the SPD is installed as close as possible to the device to be protected. The conductor length for these connections must be kept as short and as straight as possible. The SPDs are to be mounted on the 35 mm DIN-Rail. The rail is to be securely mounted to a flat surface using 1/4 inch bolts every 8 inches (200 mm). The SPDs can either be slid on the rail from an open end or put on the rail by compressing the spring loaded clamping device on the unit’s back. The SPDs shall permit sufficient clearance for power conductor routing and signaling connections.

**Conductor connections:** Phase connections to the SPD and ground side connections from the SPD to the ground bus must be within indicated wire size range and type as indicated in the technical specifications. Insulation should be stripped back as described on the previous page. All conductor terminal screws shall be tightened to the torque indicated in the technical data. If the SPDs are installed more than six conductor

feet (1.8 meters) from the neutral-to-ground bonding point (usually service entrance) then an additional SPD should be installed between neutral and ground (at the service entrance).

**Grounding:** Make sure that the SPD’s grounding is as short and straight as possible with the specified wire size according to the technical data. Use a local equipotential bonding bar if possible. For proper operation the SPD must be connected to a low impedance ground. Recommend using the largest diameter (high strand count) conductor possible without exceeding the specified maximum size.

**Remote contact signalling:** Make sure the wire size and torque is as indicated in the technical data and the remote system does not exceed the voltage and amp ratings of the Form C contact.

**Non fusing:** The Bussmann series XXXX is designed to be installed without fuses. It is suitable for use on a circuit with maximum SCCR and nominal voltage according to the technical data. This device features an internal protection that will disconnect the surge protective component at the end of its useful life while maintaining power to load – now unprotected. If this situation is undesirable for the application, the arrester module must be replaced.

**Problem diagnostics:** If there should be any problem please contact your local Bussmann series product representative.