

PASO 5

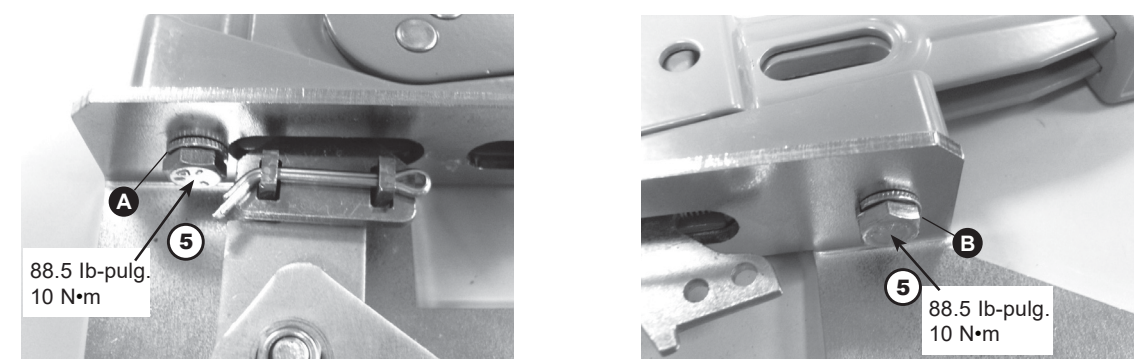

PASO 6

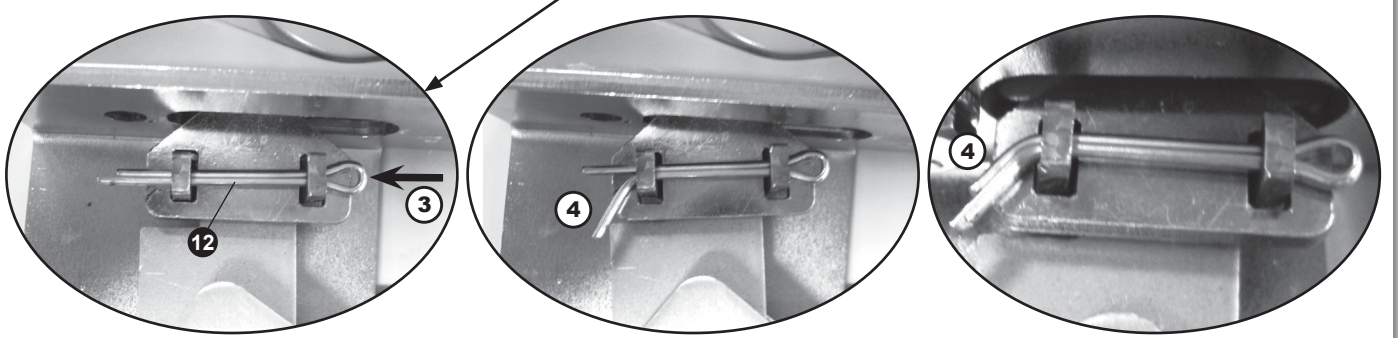
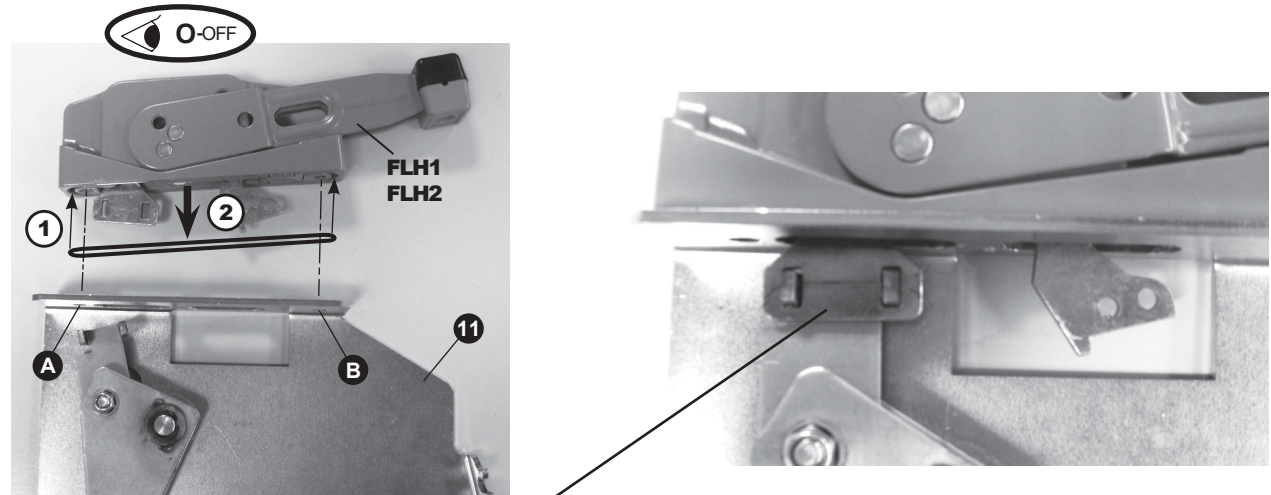
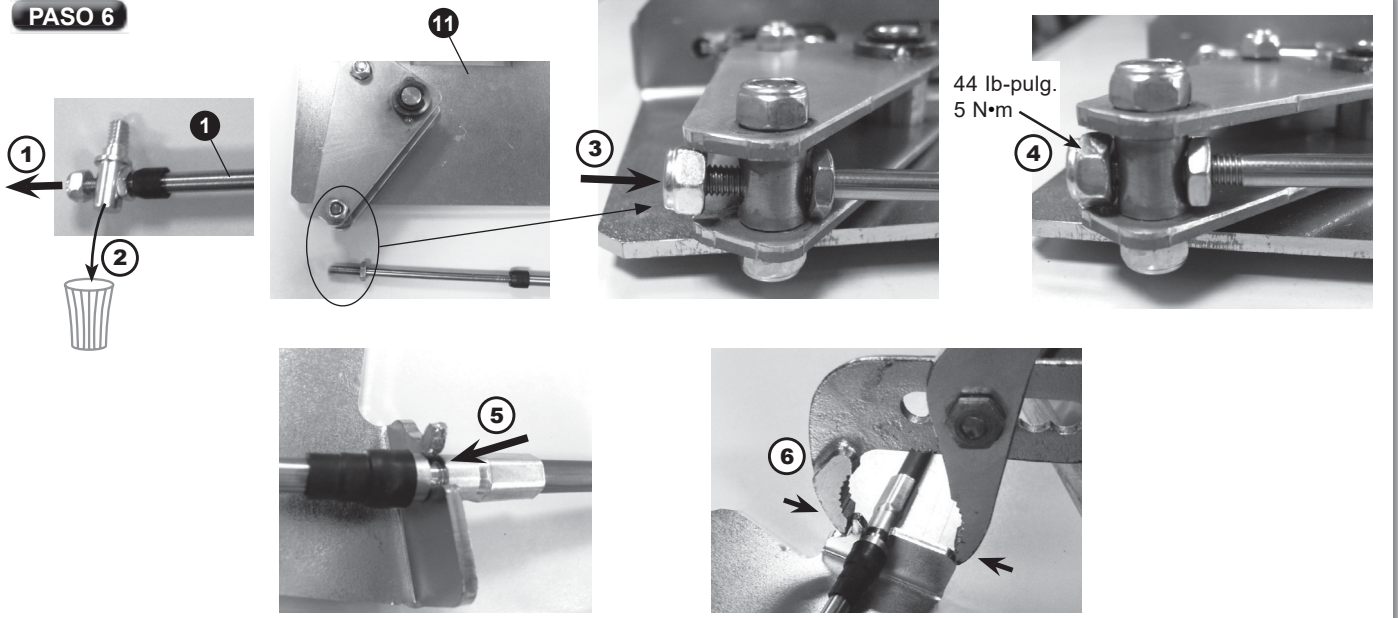

⚠ DANGER / DANGER / PELIGRO

HAZARDOUS VOLTAGE

- This equipment must be installed and serviced only by qualified electrical personnel.
- Turn off all power supplying this equipment before working on or inside equipment.
- Always use a properly rated voltage sensing device to confirm power is OFF.
- Replace all devices, doors, and covers before turning on power to this equipment.
- Maintain electrical clearances between cable and live parts.

Failure to follow these instructions will result in death or serious injury.

TENSION DANGEREUSE

- L'installation et l'entretien de cet appareil ne doivent être effectués que par du personnel qualifié.
- Coupez l'alimentation de cet appareil avant d'y travailler.
- Utilisez toujours un dispositif de détection de tension à valeur nominale approprié pour confirmer que toute alimentation est coupée.
- Remplacez tous les dispositifs, les portes et les couvercles avant de mettre cet appareil sous tension.
- Maintenez les distances d'isolement électrique entre le câble et les pièces sous tension.

Si ces précautions ne sont pas respectées, cela entraînera la mort ou des blessures graves.

TENSIÓN ELÉCTRICA PELIGROSA

- Únicamente personal capacitado y autorizado debe instalar y dar servicio a este equipo.
- Desenergice el equipo antes de realizar cualquier trabajo en él.
- Siempre utilice un dispositivo detector de tensión eléctrica adecuado para confirmar que el equipo está desenergizado.
- Antes de energizar este equipo, coloque todos los dispositivos de seguridad, cubiertas y puertas.
- Mantenga un espaciado adecuado entre el cable y las partes energizadas.

El incumplimiento de estas medidas de seguridad podrá causar la muerte o lesiones graves.

USED WITH
UTILISEES AVEC
SE UTILIZA CON

}	RDF30J-2	RDF60J-2-COMP	RDF60J-2	RDF100J-2	RDF200J-2
	RDF30J-3	RDF60J-3-COMP	RDF60J-3	RDF100J-3	RDF200J-3
	RDF30J-4	RDF60J-4-COMP	RDF60J-4	RDF100J-4	RDF200J-4

Dual dimensions in [mm]
Double dimensions in [mm]
Dimensiones pulg. [mm]

FLC36
FLC60
FLC120

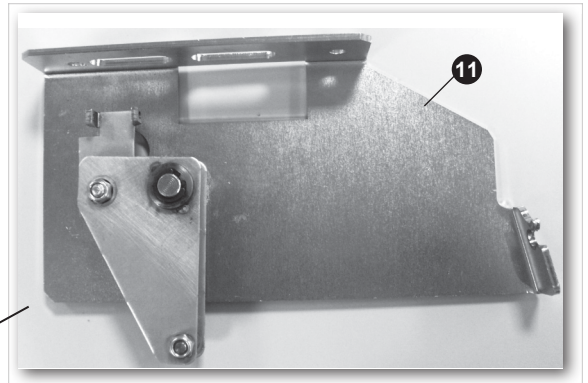

FLCM

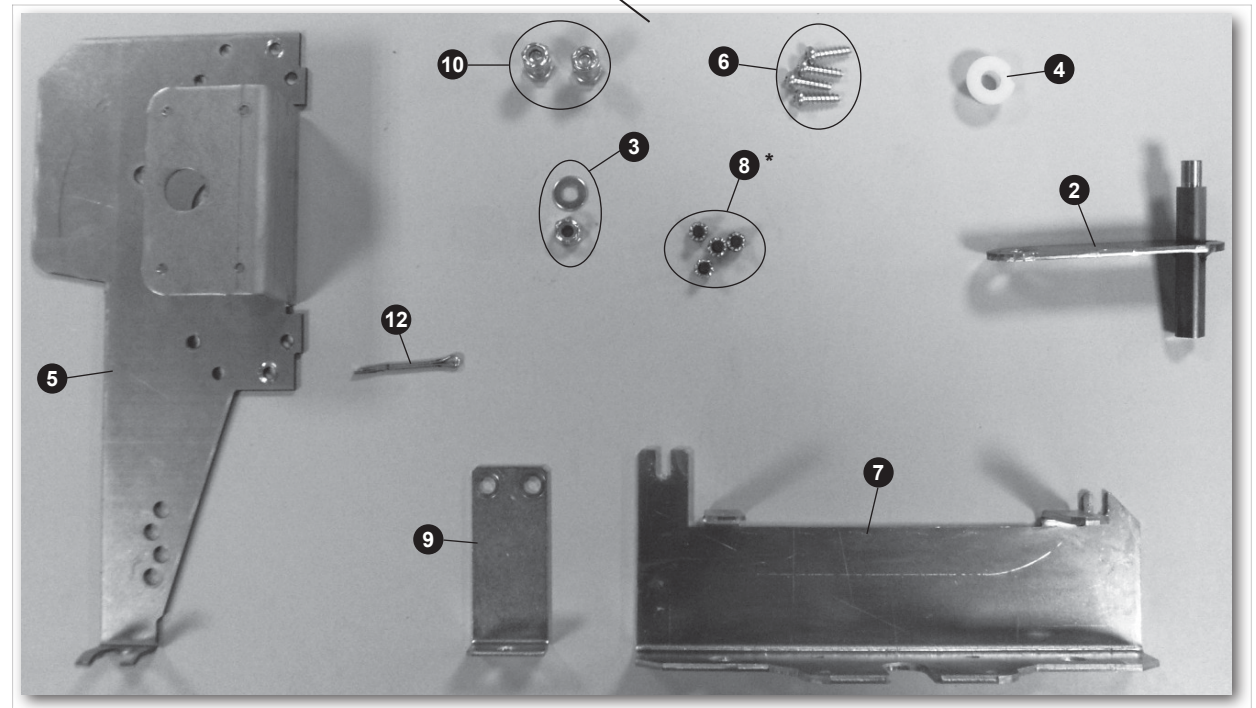

PASO 1

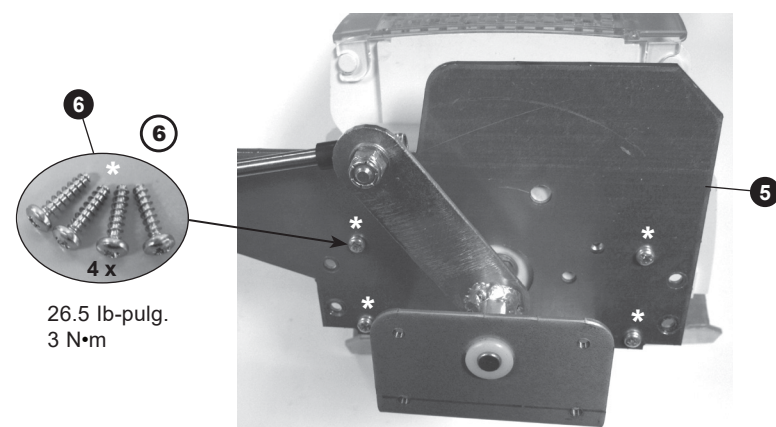
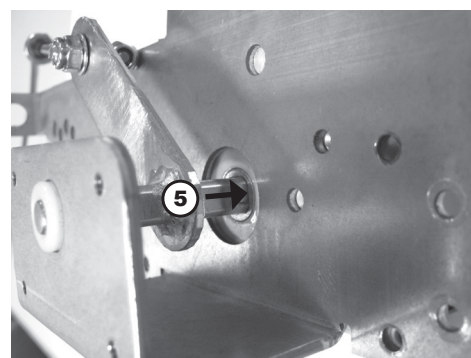
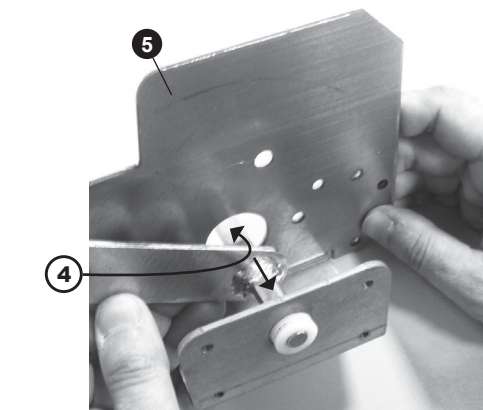
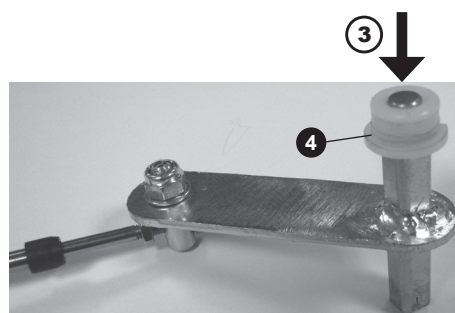
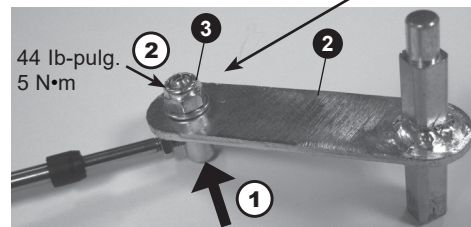
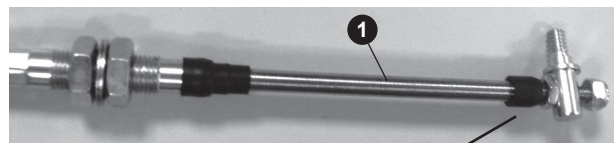

PASO 2

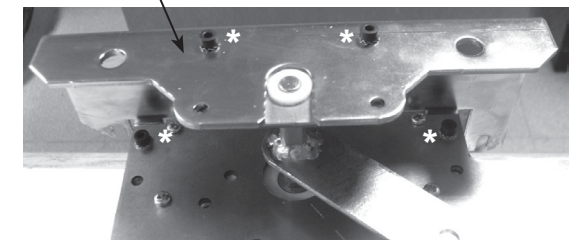
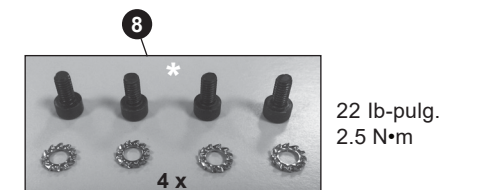
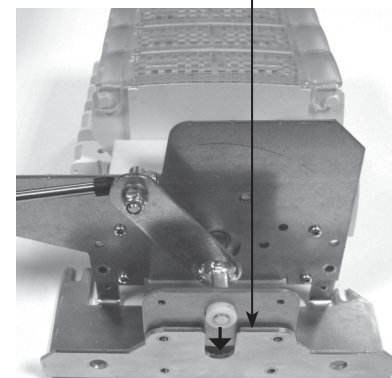
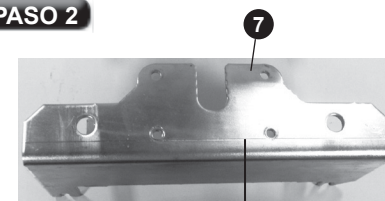

PASO 3

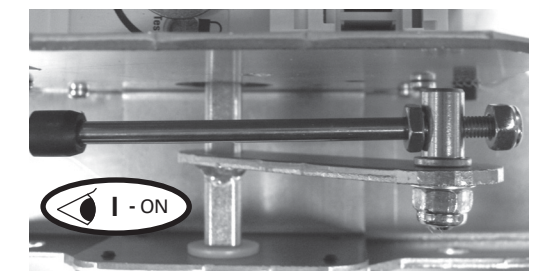
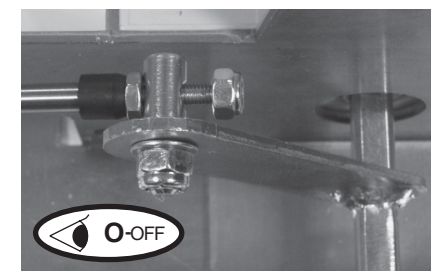
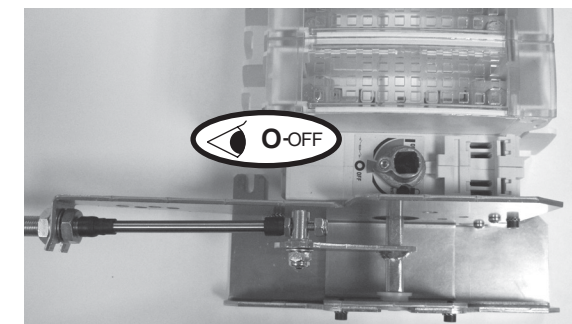
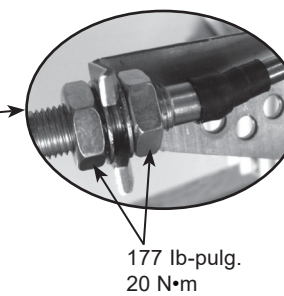
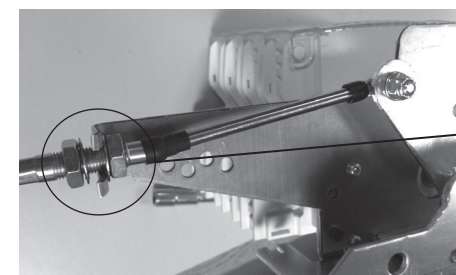

PASO 4

