

NH fuse links



Product description

Eaton's Bussmann™ series NH size 800 V a.c. fuse links are specifically designed to meet the needs of branch circuit and transformer protection in photovoltaic inverter systems.

These fuse links are capable of interrupting low overcurrents associated with faulted PV systems (reverse current, multi-array fault).

Standard features

- Compact design
- Low power loss
- Variation of fixing options
- Dual indicator feature
- Optional microswitches

Catalogue symbol

- Bladed with lugs 170M7350 to 170M7402
- Bolt holes no lugs 170M7353-B to 170M7402-B

bladed version)

- 170H0236
- 170H0238

Fuse size

- NH1, 2 and 3

Compatible fuse holders (ordered separately , only for use with bladed version)

- SD1-D
- SD2-D
- SD3-D

Technical data

- Volts: 800 V a.c.
- Amps: 32 to 400 A
- Breaking capacity: 65 kA
- Class of operation: gR

Standards/Agency information

- UL 248-13 (file number E125085)
- IEC 60269-4 (see details in technical data table 1)

Packaging

- MOQ 3

Table 1. Technical data

Microswitches (ordered separately, only for use with

Dimensions - Bladed with lugs

Catalogue number				Energy integrals I ² t (A ² S)		Watts loss
Bladed with lugs	Blade with bolt holes no lugs	Fuse body size	Current rating (Amps)	Pre-arcing	Total at 800 V a.c.	I _n
170M7350		NH1	32	80	2000	8
170M7351		NH1	40	185	3000	9
170M7352		NH1	50	400	6000	11
170M7353*	170M7353-B*	NH1	63	470	7000	12
170M7354	170M7354-B	NH1	80	640	9000	15
170M7355	170M7355-B	NH1	100	1300	17000	16
170M7356*	170M7356-B*	NH1	125	2600	34000	17
170M7357*	170M7357-B*	NH1	160	5200	68000	27
170M7358*	170M7358-B*	NH1	200	10200	140000	25
170M7397	170M7397-B	NH2	160	4600	36800	28
170M7398	170M7398-B	NH2	200	9500	76000	32
170M7399	170M7399-B	NH2	250	17000	136000	38
170M7400*	170M7400-B*	NH3	315	32000	230000	44
170M7401*		NH3	355	44500	320000	46
170M7402*		NH3	400	67500	480000	50
	170M7401-B*	NH3	355	38000	270000	48
	170M7402-B*	NH3	400	61000	430000	50

* UL 248-13 and IEC 60269-4

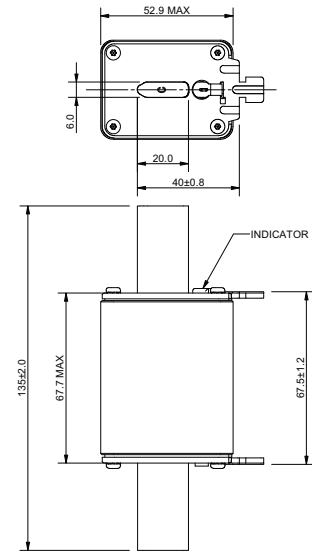

NH size 1

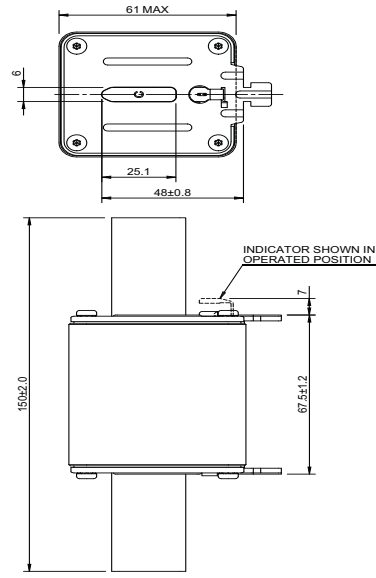
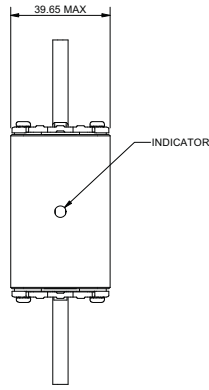

NH Size 2

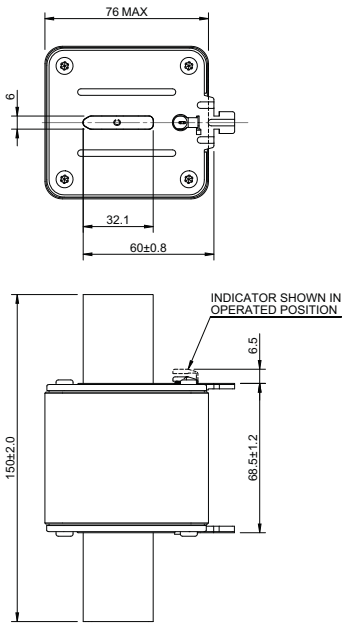
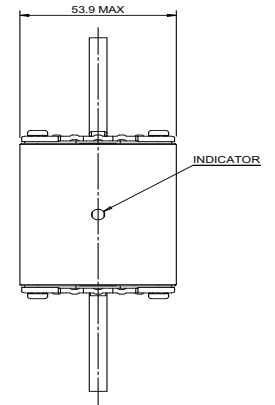

NH Size 3

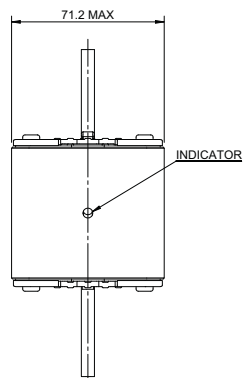

Dimensions - Bolt holes no lugs

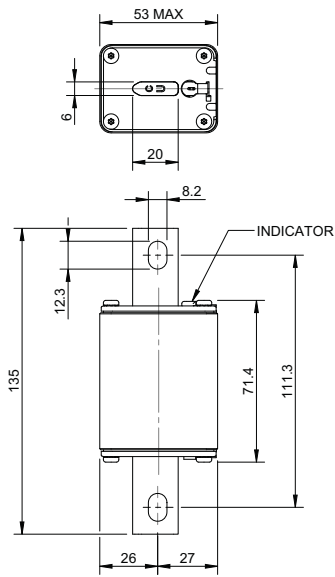

NH size 1

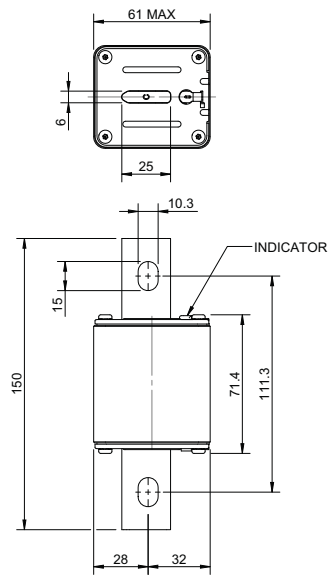
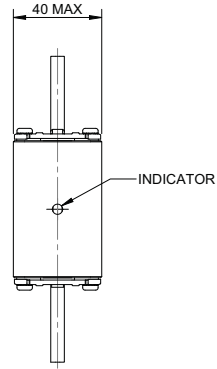

NH size 2

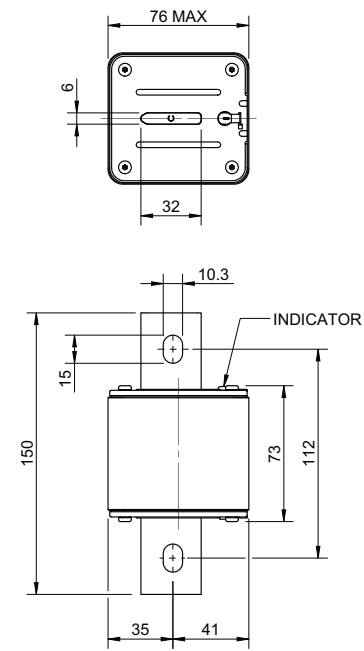
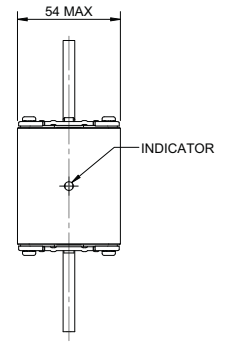

NH size 3

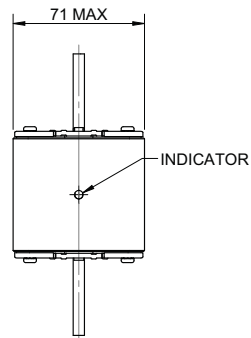

Temperature derating curve

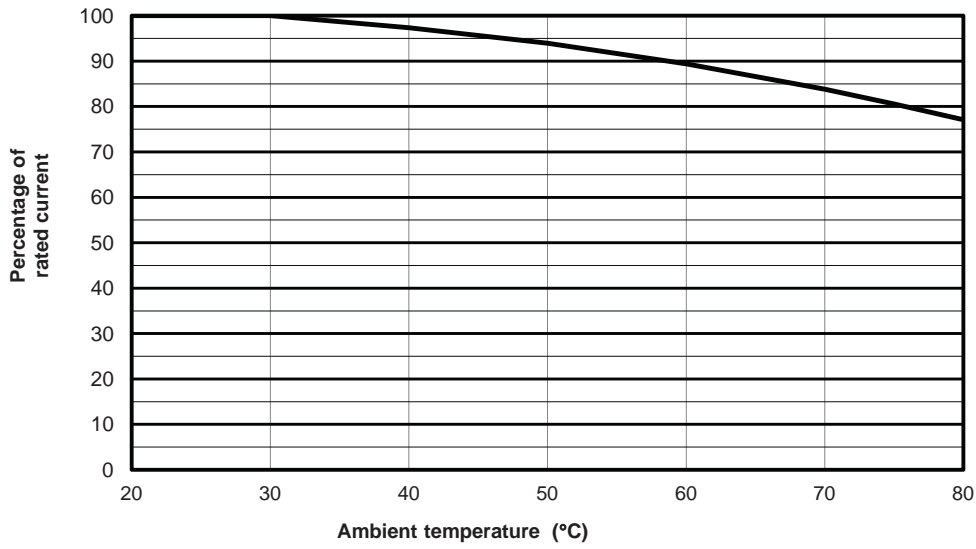

Cut-off peak current characteristic

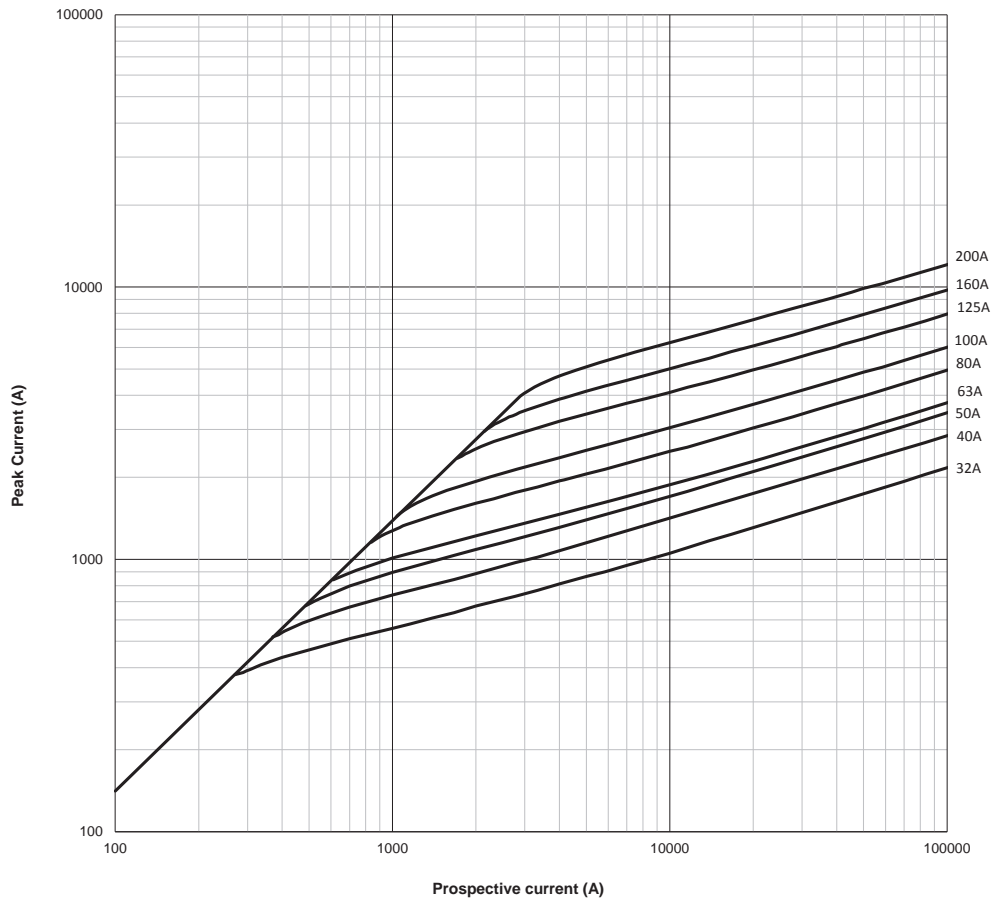

NH size 1

Cut-off peak current characteristic

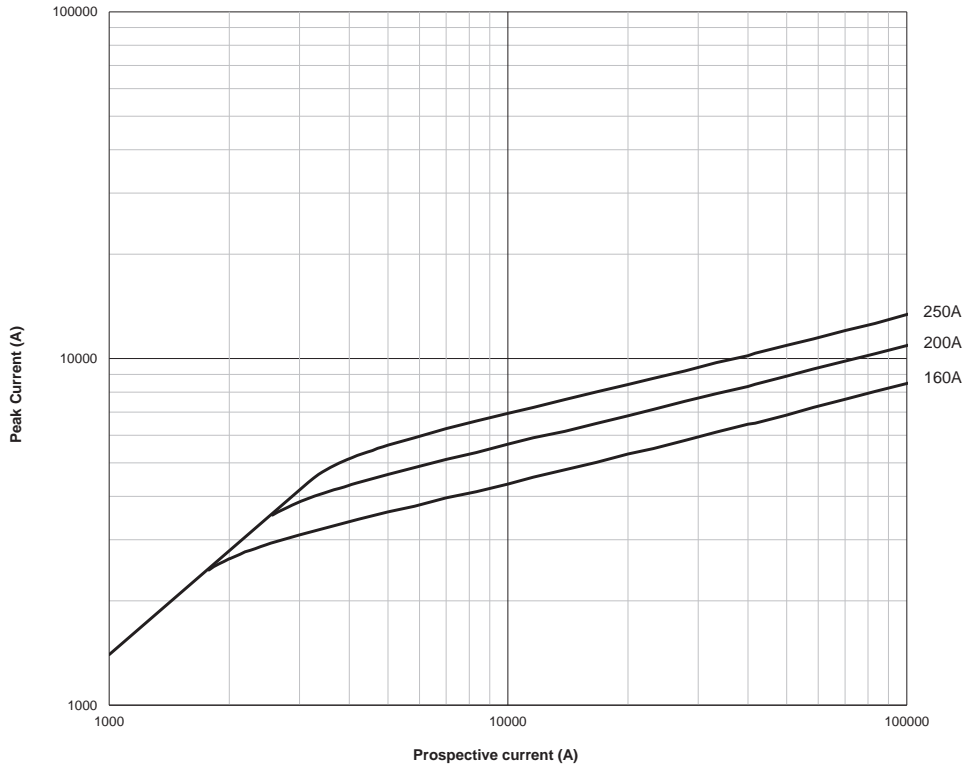

PEAK CURRENT SHOWN FOR SYMMETRICAL FAULTS ONLY

NH size 2

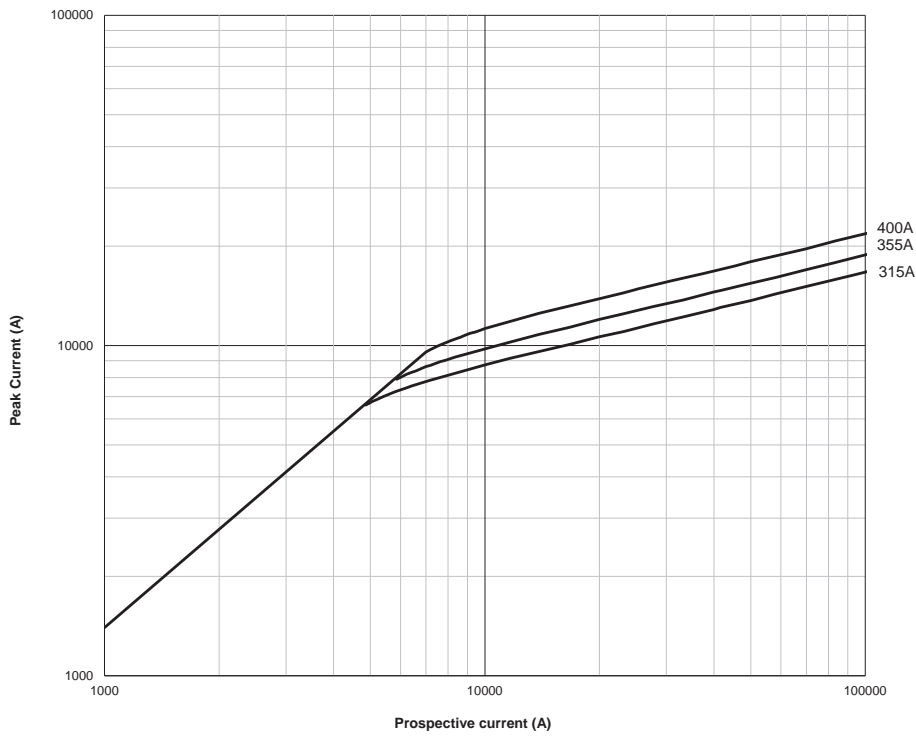

PEAK CURRENT SHOWN FOR SYMMETRICAL FAULTS ONLY

NH size 3

Time-current curve

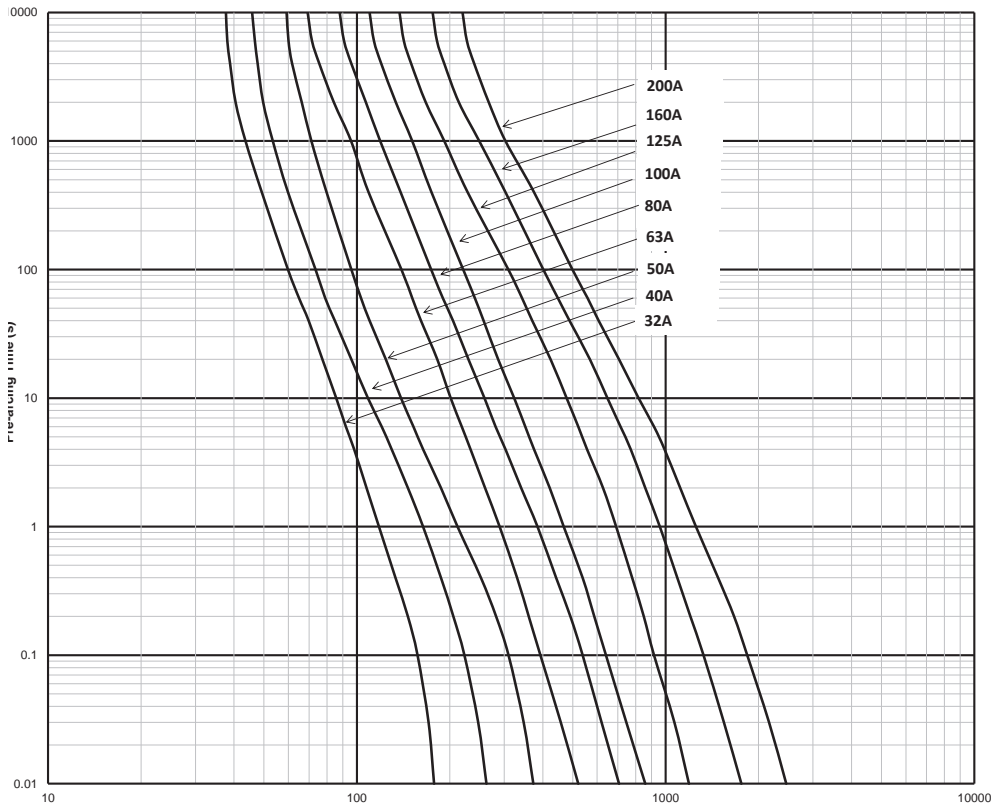

NH size 1

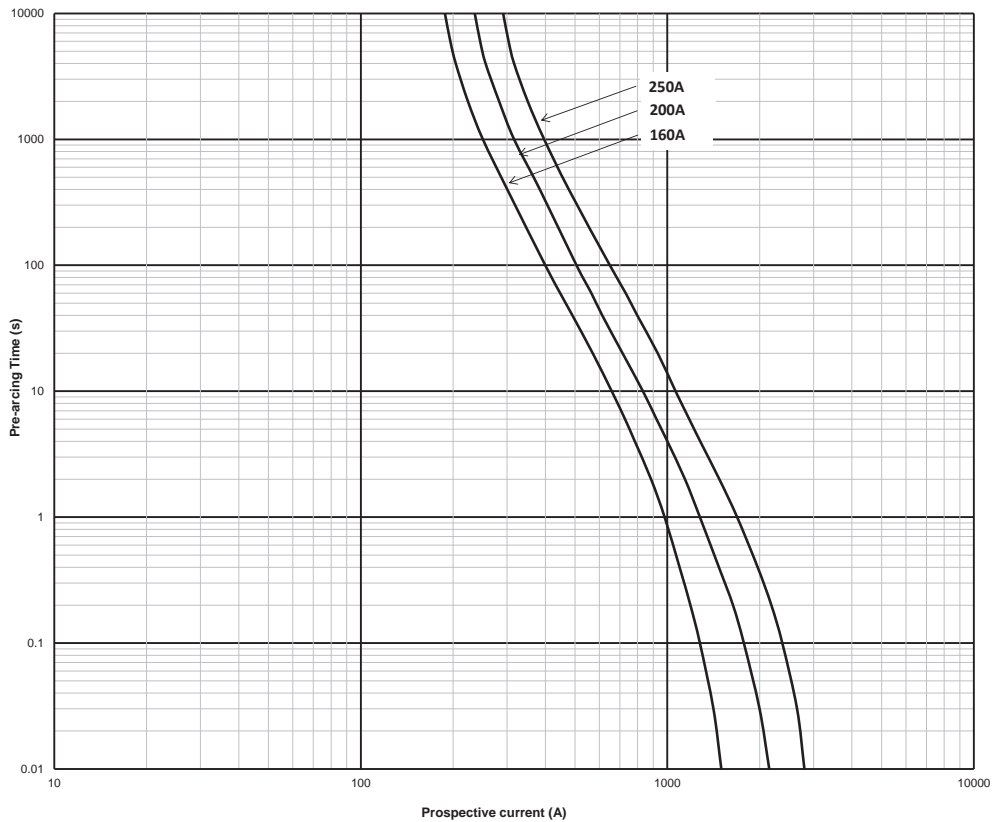

NH size 2

Time-current curve

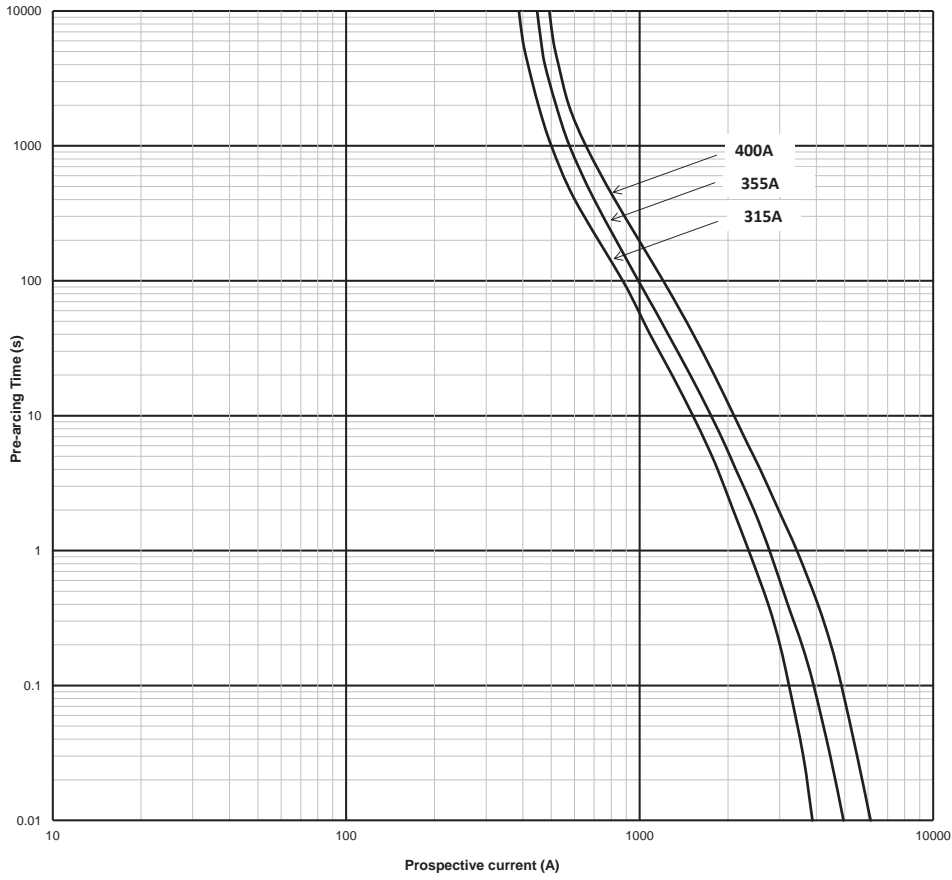

NH size 3

Time-current curve

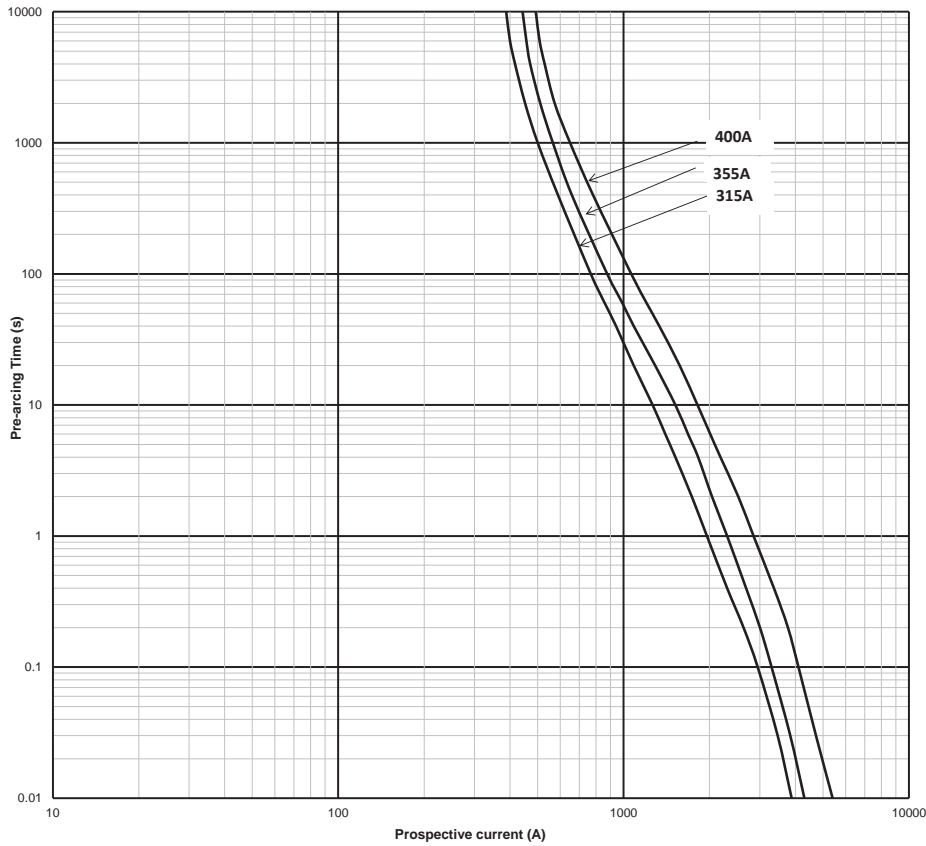

NH size 3 Bolted 170M740x-B only

Changes to the products, to the information contained in this document, and to prices are reserved; so are errors and omissions. Only order confirmations and technical documentation by Eaton is binding. Photos and pictures also do not warrant a specific layout or functionality. Their use in whatever form is subject to prior approval by Eaton. The same applies to Trademarks (especially Eaton, Moeller, and Cutler-Hammer). The Terms and Conditions of Eaton apply, as referenced on Eaton Internet pages and Eaton order confirmations.

Eaton
 EMEA Headquarters
 Route de la Longeraie 7
 1110 Morges, Switzerland

Eaton Electrical Products Limited
 Melton Road
 Burton-on-the-Wolds
 Leicestershire, LE12 5TH
 United Kingdom

© 2017 Eaton
 All Rights Reserved
 PDF Only
 Publication No. 10784
 May 2018