

E-Rated DIN medium voltage fuses, 5.5 to 38 kV, 10 to 450 amps



Catalog symbols:

- 55GDMSJ_E
- 55GFMSJ_E
- 155GXQSJ_E
- 175GDMSJ_E
- 175GFMSJ_E
- 175GXMSJ_E
- 175GXQSJ_E
- 258GDQSJ_E
- 258GXQSJ_E
- 258GXZSJ_E
- 38GFZSJ_E
- 38GCZSJ_E

Description:

Bussmann™ series DIN dimensioned E-Rated medium voltage power fuses with striker for indoor use. Available in general purpose (5.5 to 17.5 kV) and full range (25.8 to 38 kV) versions.

Specifications:

Ratings

- Volts 5.5 - 38 kV
- Amps: 10 - 450
- Interrupting rating: 25 - 65 kA

Agency information

- General purpose E-Rated per ANSI C37.46 (5.5 to 17.5 kV)
- Full range E-Rated per ANSI C37.40 (25.8 to 38 kV)

Striker force

- 50 N (11 Lbs)

Recommended fuseclips

See page 13 for dimensions.

Amp range	Description	Catalog no.
Up to 200 A	Enclosed fuseclip with wingnut tensioner	A33574745*
Up to 200 A	Open fuseclip with spring tensioner	270303

* Not sold in pairs.

Features and benefits

- Cool running for lower watts loss
- 100% X-ray inspected to help assure fuse integrity
- Striker provides visual indication of fuse operation or a means to activate a remote monitoring system

Typical applications

- Primary protection for medium voltage transformers and switch gear
- Protection of medium voltage feeder circuits
- Direct OEM replacement fuses for 600 A Square D HVLCC and HVL switches — see page 14 for applicable Square D switch catalog symbols and Bussmann series fuse voltage and amp ranges



Powering Business Worldwide

Catalog numbers — general purpose versions

Catalog numbers	Amps	Interrupting rating (Sym. kA)	Dimensions — in (mm)	
			Length	Diameter
5.5 kV				
55GDMSJ10E	10	65	17.4 (442)	2 (51)
55GDMSJ15E	15			
55GDMSJ20E	20			
55GDMSJ25E	25			
55GDMSJ30E	30			
55GDMSJ40E	40			
55GDMSJ50E	50		17.4 (442)	3 (76)
55GDMSJ65E	65			
55GDMSJ80E	80			
55GDMSJ100E	100			
55GDMSJ125E	125			
55GFMSJ150E	150			
55GFMSJ175E	175		21.1 (537)	3.5 (89)
55GFMSJ200E	200			
55GFMSJ250E	250			
55GFMSJ300E	300			
55GFMSJ350E	350			
55GFMSJ400E	400			
55GFMSJ450E	450			
15.5 kV				
155GXQSJ175E	175	65	21.1 (537)	3.5 (89)
155GXQSJ200E	200			
17.5 kV				
175GDMSJ10E	10	65	17.4 (442)	2 (51)
175GDMSJ15E	15			
175GDMSJ20E	20			
175GDMSJ25E	25			
175GDMSJ30E	30			
175GFMSJ40E	40			
175GFMSJ50E	50			
175GFMSJ65E	65			
175GXMSJ80E	80			
175GXMSJ100E	100			
175GXQSJ125E	125		21.1 (537)	3.5 (89)
175GXQSJ150E	150			

Dimensions — in (mm)

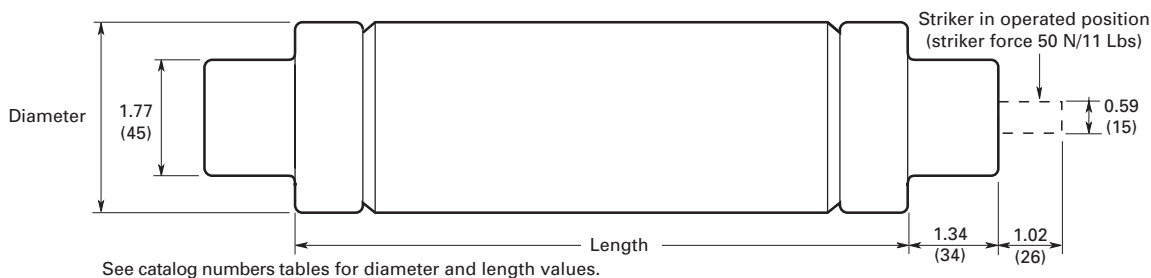

Catalog numbers — full range versions

Catalog numbers	Amps	Interrupting rating (Sym. kA)	Dimensions — in (mm)	
			Length	Diameter
25.8 kV				
258GDQSJ10E	10	25	21.1 (537)	2 (51)
258GDQSJ15E	15			
258GDQSJ20E	20			
258GDQSJ25E	25			
258GDQSJ30E	30		21.1 (537)	3.5 (89)
258GXQSJ40E	40			
258GXQSJ50E	50			
258GXQSJ65E	65			
258GXZSJ80E	80			
258GXZSJ100E	100			
38 kV				
38GFZSJ10E	10	25	28.3 (718)	3 (76)
38GFZSJ15E	15			
38GFZSJ20E	20			
38GFZSJ25E	25			
38GFZSJ30E	30			

Dimensions — in (mm)

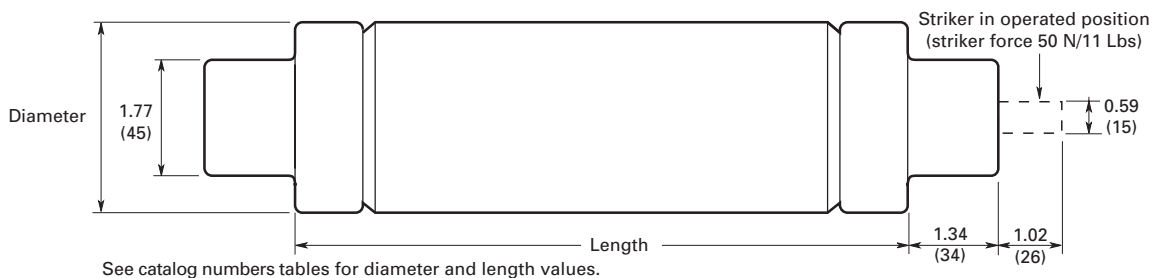

5.5 kV time-current curves — minimum melting

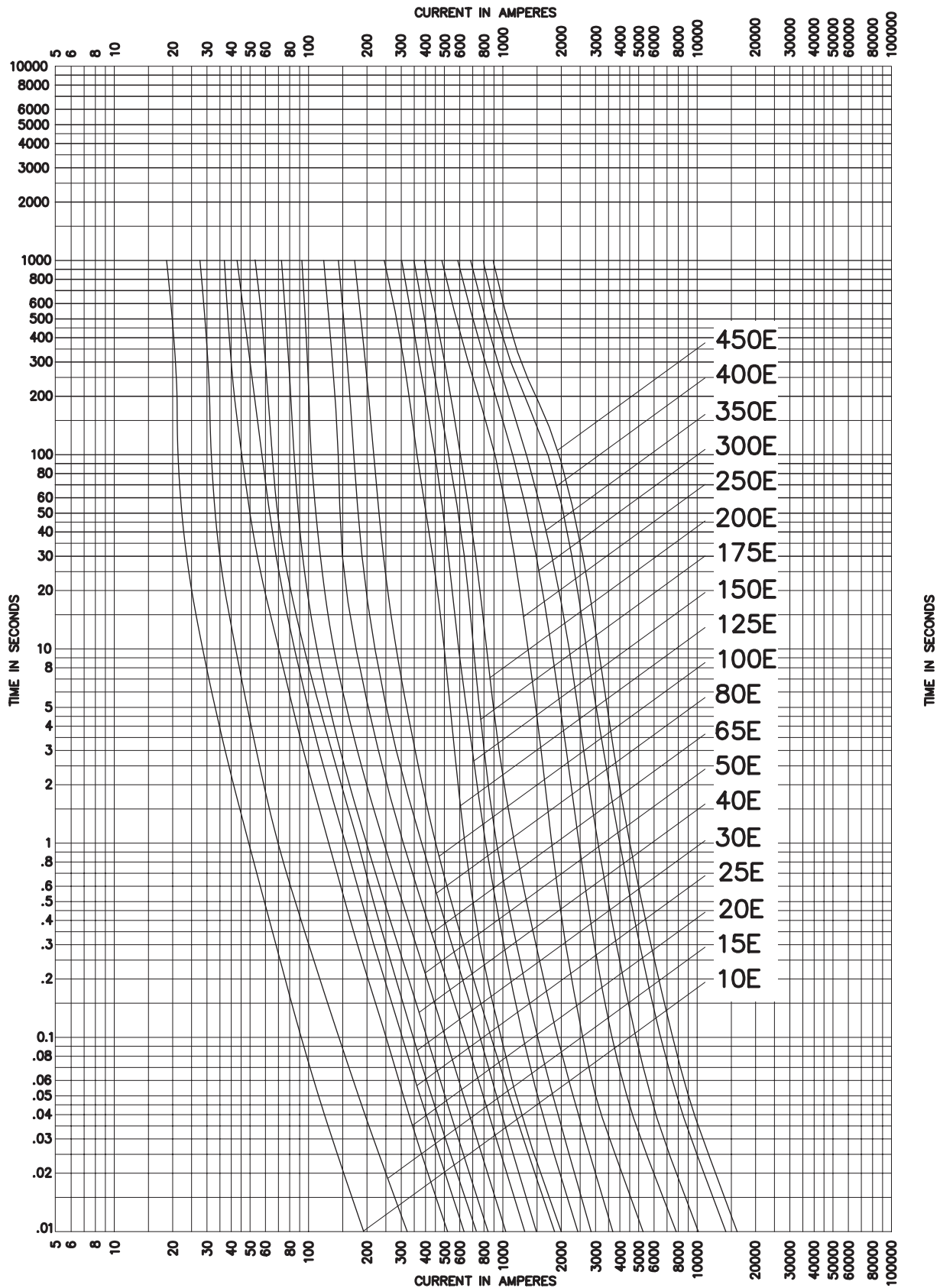

5.5 kV time-current curves — total clearing

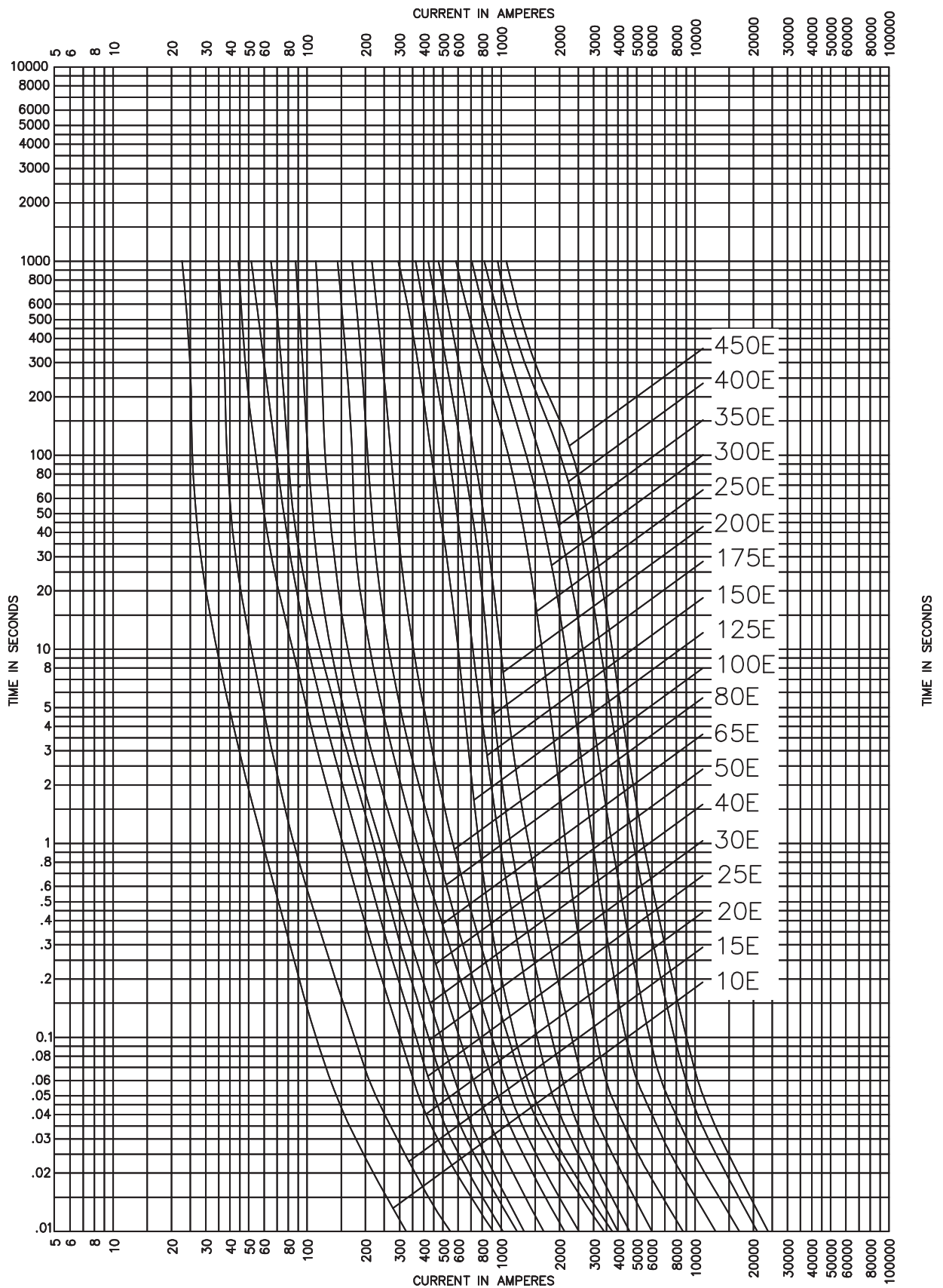

5.5 kV cut-off curves

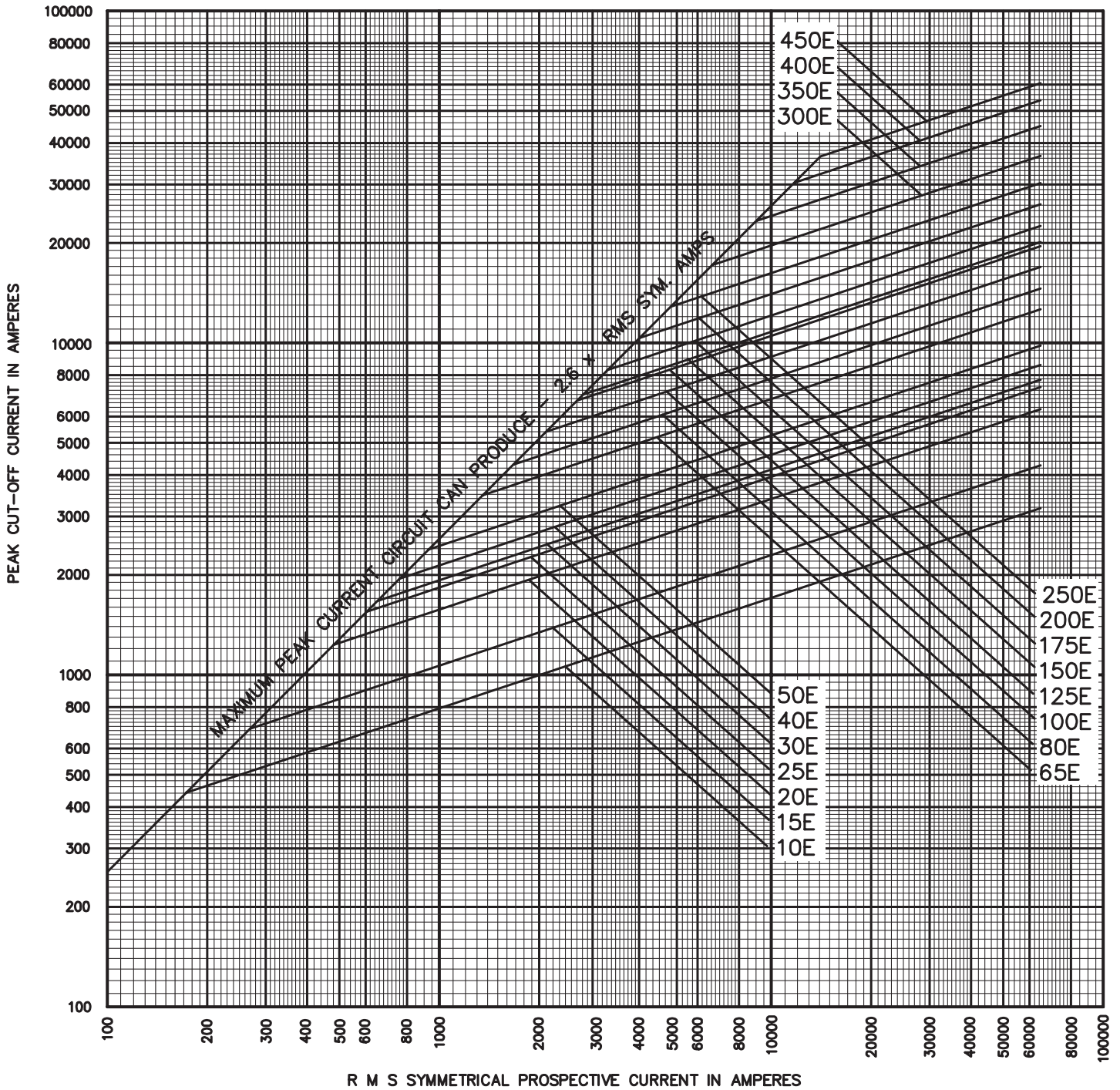

- Notes:**
1. Curves show extreme maximum values which will not be exceeded under conditions stated in notes 2 and 3 below.
 2. For high values of prospective current, a symmetrical fault gives the highest cut-off current. For low values of prospective current, where there is little or no current limitation, an asymmetrical fault passes the highest peak current. The curves are therefore based upon the degree of asymmetry which gives the maximum cut-off current at any particular value of prospective current.
 3. Curves related to frequency of 60 Hz and a recovery voltage equal to the fuse's rated voltage.

15.5 to 17.5 kV time-current curves — minimum melting

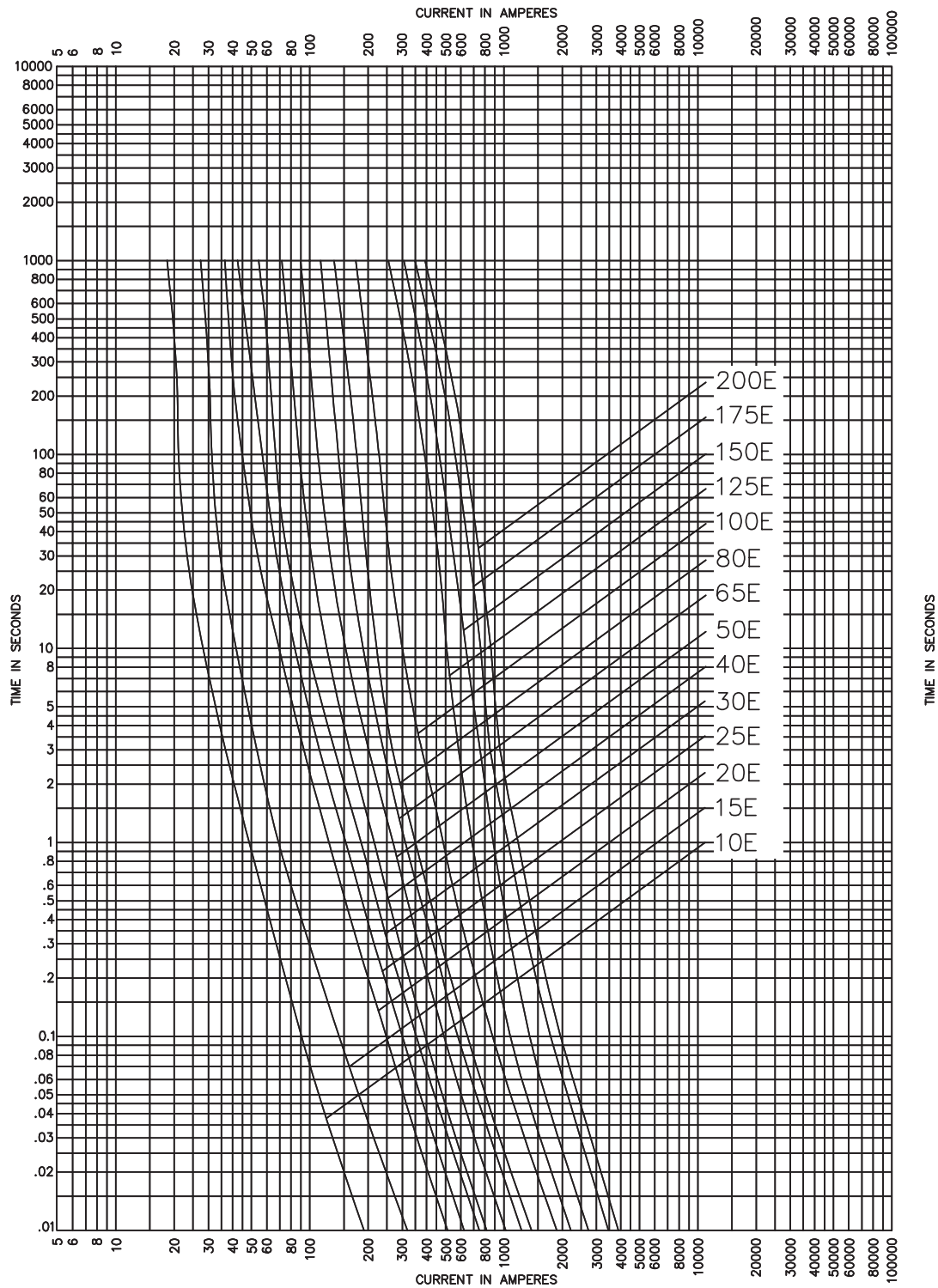

15.5 to 17.5 kV time-current curves — total clearing

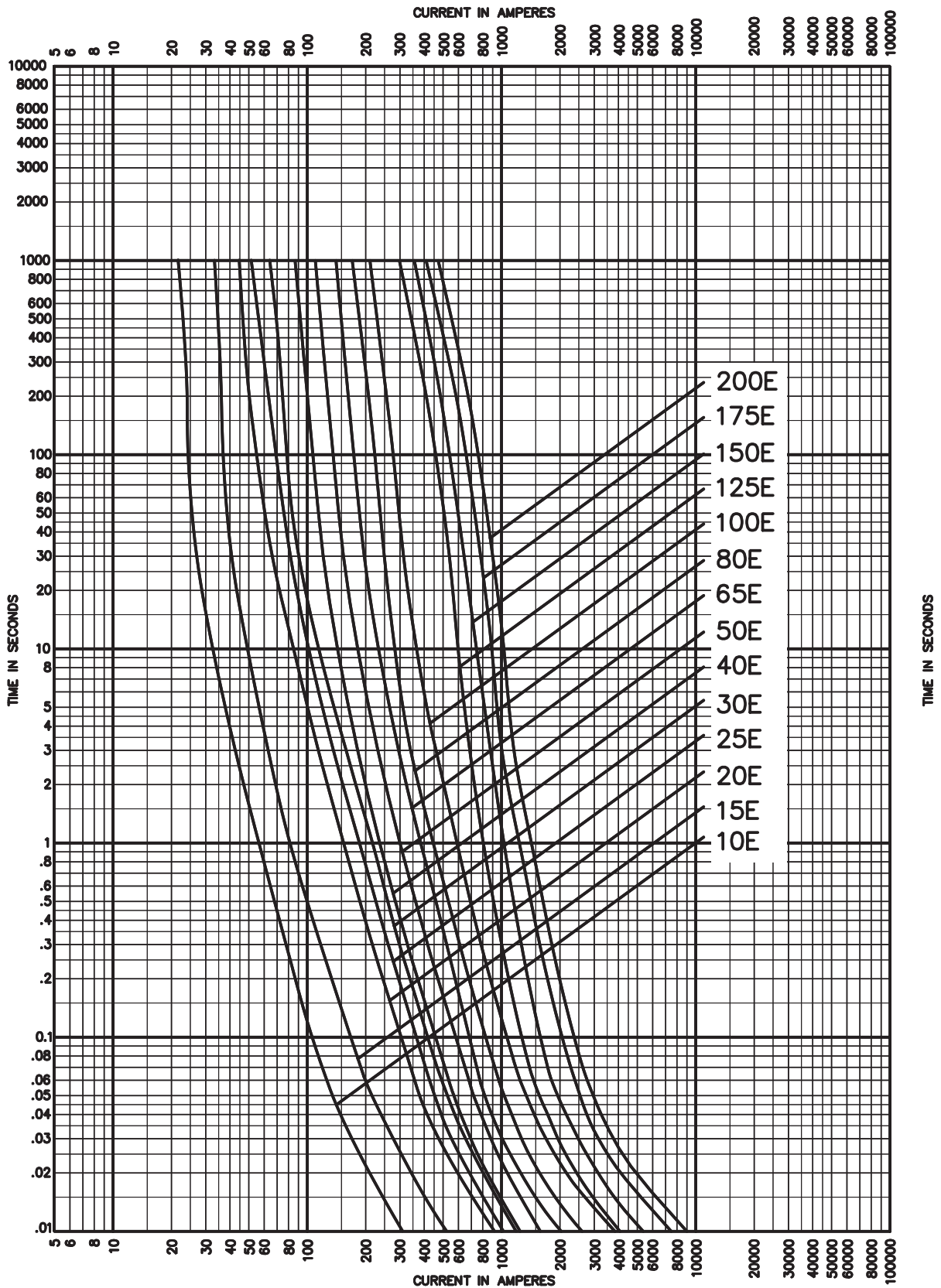

15.5 to 17.5 kV cut-off curves

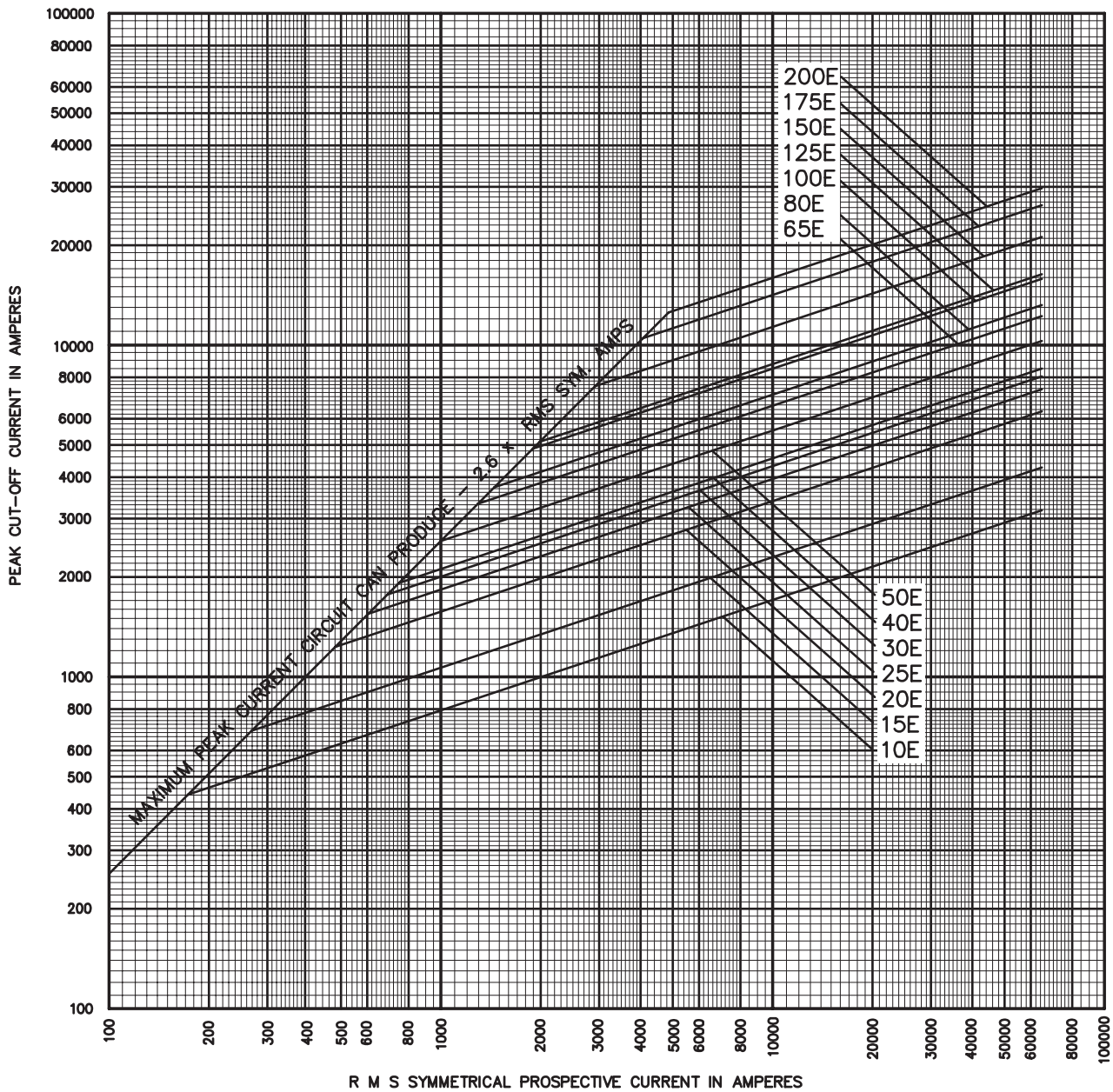

Notes:

1. Curves show extreme maximum values which will not be exceeded under conditions stated in notes 2 and 3 below.
2. For high values of prospective current, a symmetrical faults gives the highest cut-off current. For low values of prospective current, where there is little or no current limitation, an asymmetrical fault passes the highest peak current. The curves are therefore based upon the degree of asymmetry which gives the maximum cut-off current at any particular value of prospective current.
3. Curves related to frequency of 60 Hz and a recovery voltage equal to the fuse's rated voltage.

25.8 to 38 kV time-current curves – minimum melting

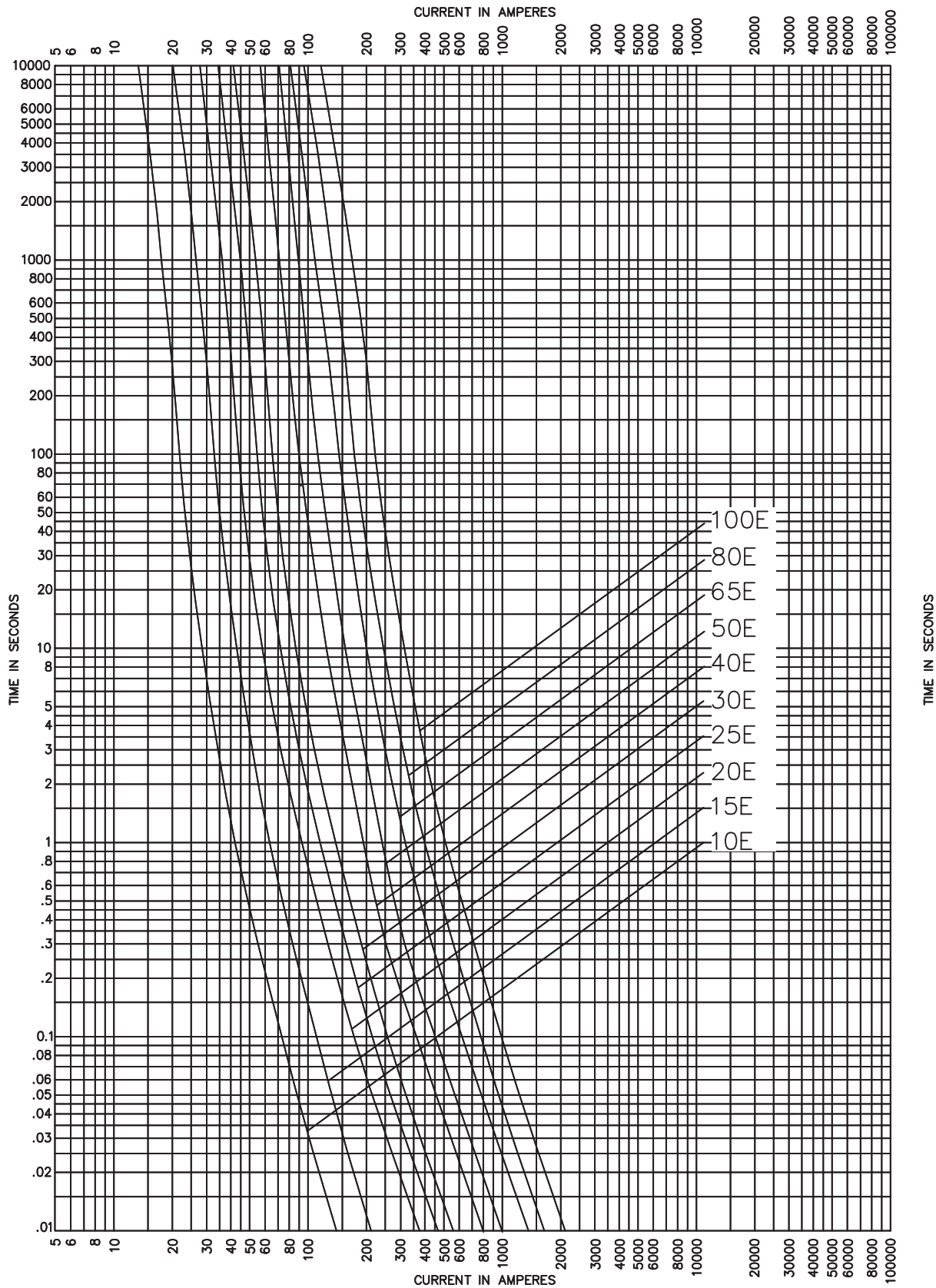

25.8 to 38 kV time-current curves – total clearing

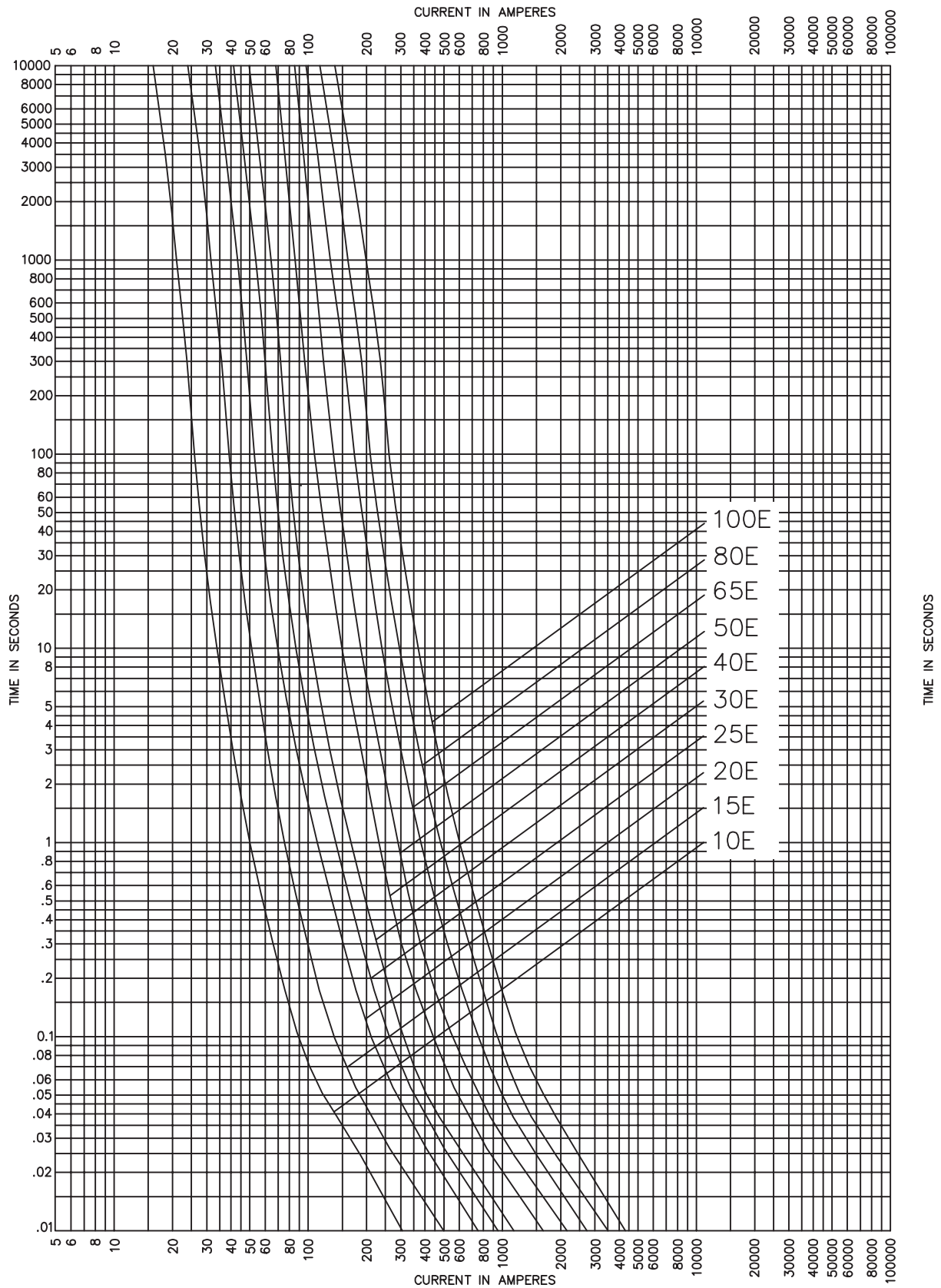

25.8 to 38 kV cut-off curves

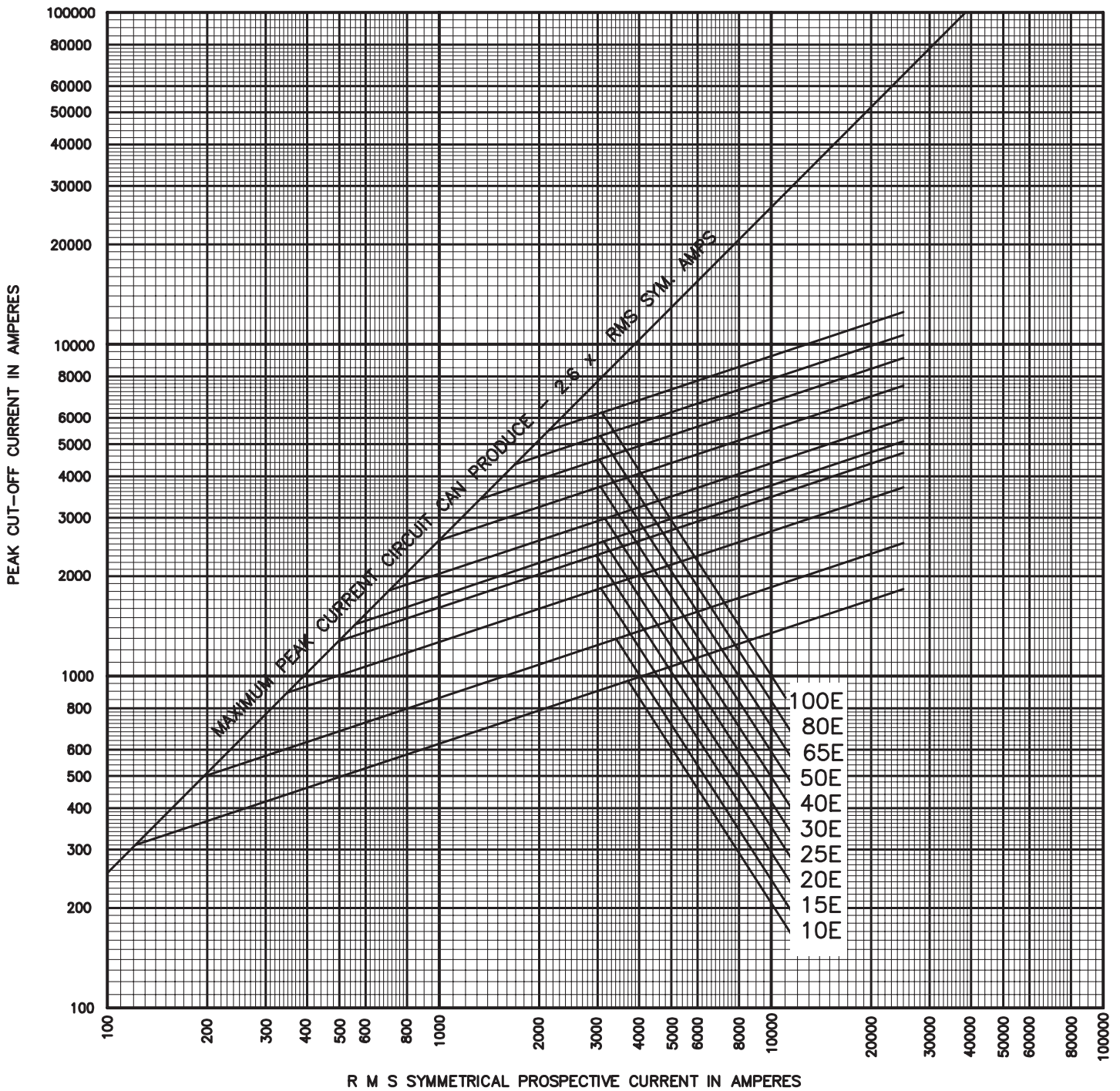

- Notes:**
1. Curves show extreme maximum values which will not be exceeded under conditions stated in notes 2 and 3 below.
 2. For high values of prospective current, a symmetrical fault gives the highest cut-off current. For low values of prospective current, where there is little or no current limitation, an asymmetrical fault passes the highest peak current. The curves are therefore based upon the degree of asymmetry which gives the maximum cut-off current at any particular value of prospective current.
 3. Curves related to frequency of 60 Hz and a recovery voltage equal to the fuse's rated voltage.

Fuseclip dimensions in (mm)

Catalog no. A3354745 – not sold in pairs

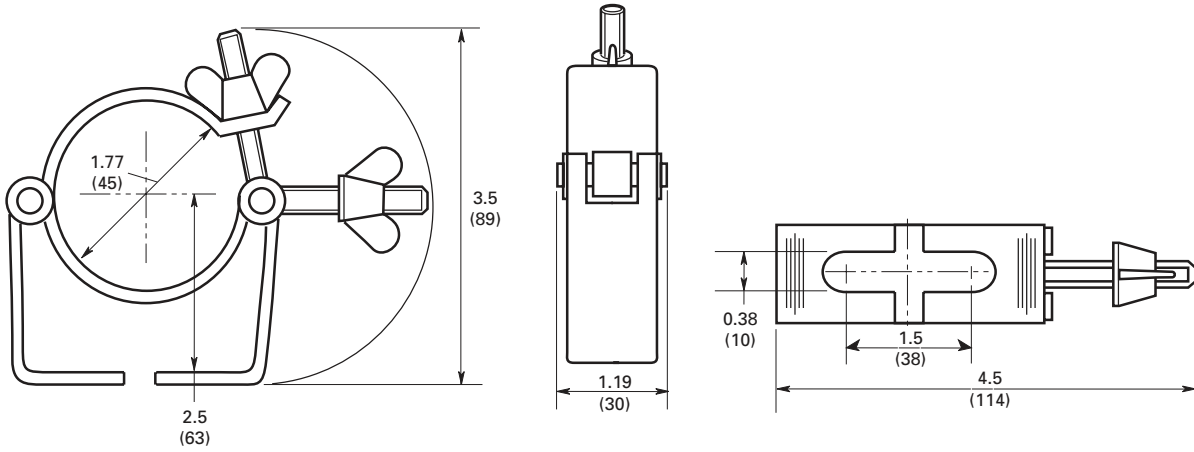

Catalog no. 270303

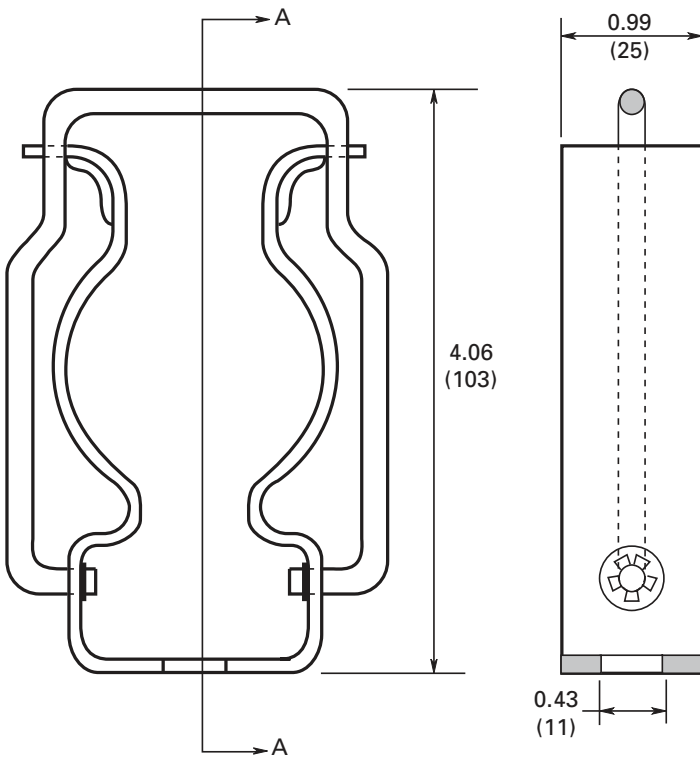

Bussmann series fuse amp ranges for Square D 600A HVL/CC and HVL switches

Catalog numbers		Fuse voltage (kV)	Fuse range		
HVL/CC versions	HVL versions				
Single switch with Square D fuses					
4.76 kV switch volts					
HVLCCA14305D	HVL305DE_	5.5	10-450E		
HVLCCA20305D	—				
HVLCCB14305D	—				
HVLCCB20305D	—				
15 kV switch volts					
HVLCCA14315D	—	15.5 or 17.5	10-200E		
HVLCCA20315D	—				
HVLCCB14315D	—				
HVLCCB20315D	—				
—	HVL315DEG2				
—	HVL315DEW2				
—	HVL315DEG1				
—	HVL315DEW1				
"Single" switch for cable connection to Power-Dry II, Power-Cast II, and Uni-Cast II transformers					
4.76 kV switch volts					
HVLCCA14405DGL	HVL405DEG_	5.5	10-450E		
HVLCCA14405DGR	HVL405DEW_				
HVLCCA20405DGL	—				
HVLCCA20405DGR	—				
HVLCCB14405DGL	—				
HVLCCB14405DGR	—				
HVLCCB20405DGL	—				
HVLCCB20405DGR	—				
15 kV switch volts					
HVLCCA14415DGL	—			15.5 or 17.5	10-200E
HVLCCA14415DGR	—				
HVLCCA20415DGL	—				
HVLCCA20415DGR	—				
HVLCCB14415DGL	—				
HVLCCB14415DGR	—				
HVLCCB20415DGL	—				
HVLCCB20415DGR	—				
—	HVL415DEGR1				
—	HVL415DEGR2				
—	HVL415DEGL1				
—	HVL415DEGL2				
—	HVL415DEWR1H				
—	HVL415DEWR2H				
—	HVL415DEWL1H				
—	HVL415DEWL2H				
"Duplex" switch for cable connection to Power-Dry II, Power-Cast II, and Uni-Cast II transformers					
4.76 kV switch volts					
HVLCCA14505DGL	HVL505DEG_	5.5	10-450E		
HVLCCA14505DGR	HVL505DEW_				
HVLCCA20505DGL	—				
HVLCCA20505DGR	—				
HVLCCB14505DGL	—				
HVLCCB14505DGR	—				
HVLCCB20505DGL	—				
HVLCCB20505DGR	—				
15 kV switch volts					
HVLCCA14515DGL	—			15.5 or 17.5	10-200E
HVLCCA14515DGR	—				
HVLCCA20515DGL	—				
HVLCCA20515DGR	—				
HVLCCB14515DGL	—				
HVLCCB14515DGR	—				
HVLCCB20515DGL	—				
HVLCCB20515DGR	—				
—	HVL515DEGR1				
—	HVL515DEGR2				
—	HVL515DEGL1				
—	HVL515DEGL2				
—	HVL515DEWR1H				
—	HVL515DEWR2H				
—	HVL515DEWL1H				
—	HVL515DEWL2H				

The only controlled copy of this data sheet is the electronic read-only version located on the Eaton network drive. All other copies of this document are by definition uncontrolled. This bulletin is intended to clearly present comprehensive product data and provide technical information that will help the end user with design applications. Eaton reserves the right, without notice, to change design or construction of any products and to discontinue or limit distribution of any products. Eaton also reserves the right to change or update, without notice, any technical information contained in this bulletin. Once a product has been selected, it should be tested by the user in all possible applications.

Eaton
1000 Eaton Boulevard
Cleveland, OH 44122
Eaton.com

Bussmann Division
114 Old State Road
Ellisville, MO 63021
United States
Eaton.com/bussmannseries

© 2017 Eaton
All Rights Reserved
Printed in USA
Publication No. 10638 — BU-MC17000
April 2017

Eaton and Bussmann are valuable trademarks of Eaton in the U.S. and other countries. You are not permitted to use the Eaton trademarks without prior written consent of Eaton.

For Eaton's Bussmann series product information, call **1-855-287-7626** or visit: **Eaton.com/bussmannseries**

Follow us on social media to get the latest product and support information.

