

Bussmann

NH Photovoltaic Fuse Links



Product description:

Bussmann's range of NH size fuse photovoltaic fuse links is specifically designed to protect and isolate photovoltaic array combiners and disconnects.

These fuse links are capable of interrupting low overcurrents associated with faulted PV systems (reverse current, multi-array fault).

Standard features:

- Compact design
- Low power loss
- Global accreditations
- Dual indication feature
- Compatible with Bussmann PV NH base range (see data sheet 720136)

Catalogue symbol: PV-(amp rating)ANH(size)

Fuse size: NH1, 2 and 3

Technical data:

Volts: 1000Vdc

Amps: 32 to 400A

Breaking capacity: 50kA

Time constant: 1-3mS

Class of operation: gPV and UL PV fuse links

Standards/Approvals:

- IEC 60269-6
- UL 2579 (file number E335324) for size 1 only, pending for sizes 2 and 3
- CSA listed
- RoHS compliant
- CCC pending

Microswitches:

- 170H0236
- 170H0238

Fuse holders (ordered separately)

- SD1-D-PV
- SD2-D-PV
- SD3-D-PV

Packaging: MOQ 3

Technical Data

Part number	Fuse size	Current rating (amps)	Energy Integrals I ² t (A ² S)		Watts loss	
			Pre-arcing	Total at 1000V	0.8 I _n	I _n
PV-32ANH1	NH1	32	80	720	4.3	8.5
PV-40ANH1		40	185	1670	4.6	9
PV-50ANH1		50	400	3600	5.4	10.5
PV-63ANH1		63	470	4300	6.1	12
PV-80ANH1		80	640	5760	7.9	15.5
PV-100ANH1		100	1300	11,700	8.4	16.5
PV-125ANH1		125	2600	23,400	8.9	17.5
PV-160ANH1		160	5200	46,800	12.2	24
PV-200ANH1		200	10,200	82,000	13	25
PV-250ANH2		NH2	250	26,000	129,000	23
PV-400ANH3	NH3	400	85,000	420,000	30	50

NH Size 1 dimensions - mm

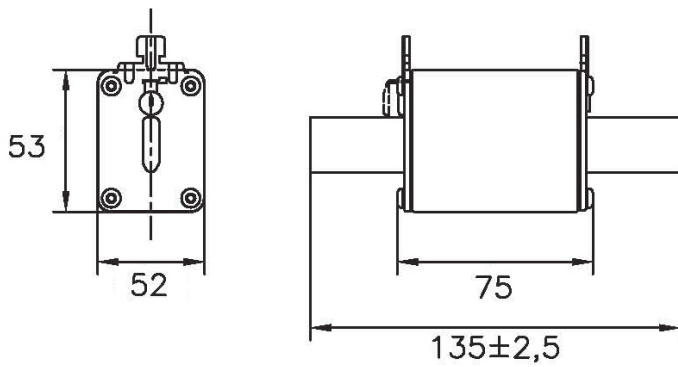

NH Size 2 dimensions - mm

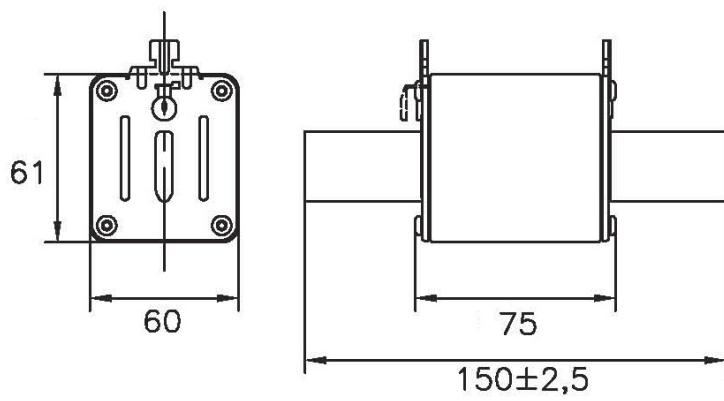

NH Size 3 dimensions - mm

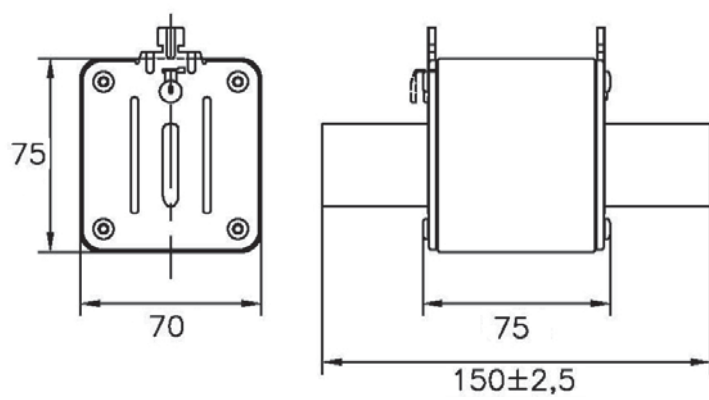

Time-current curves - NH size 1

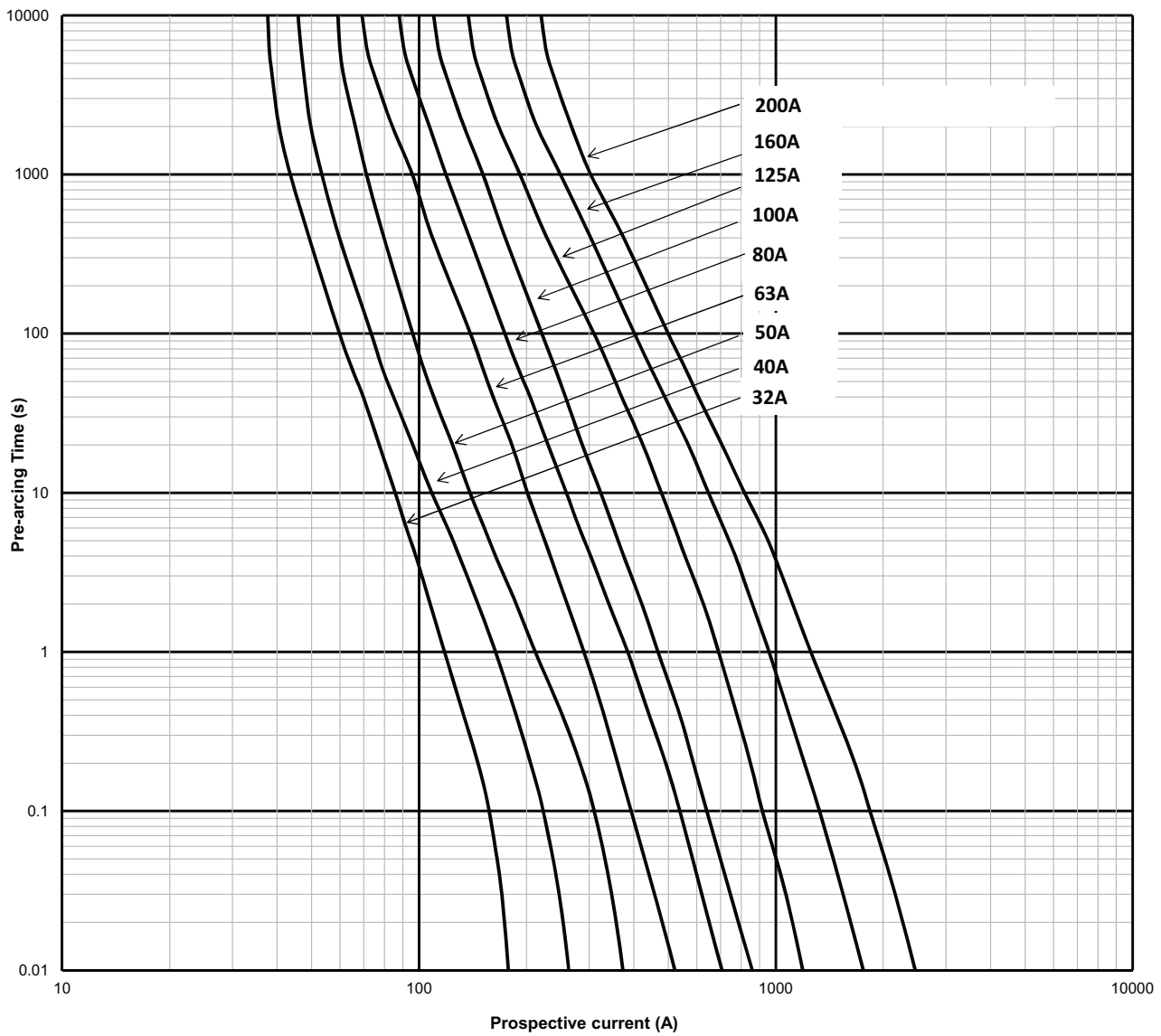

Time-current curves - NH size 2

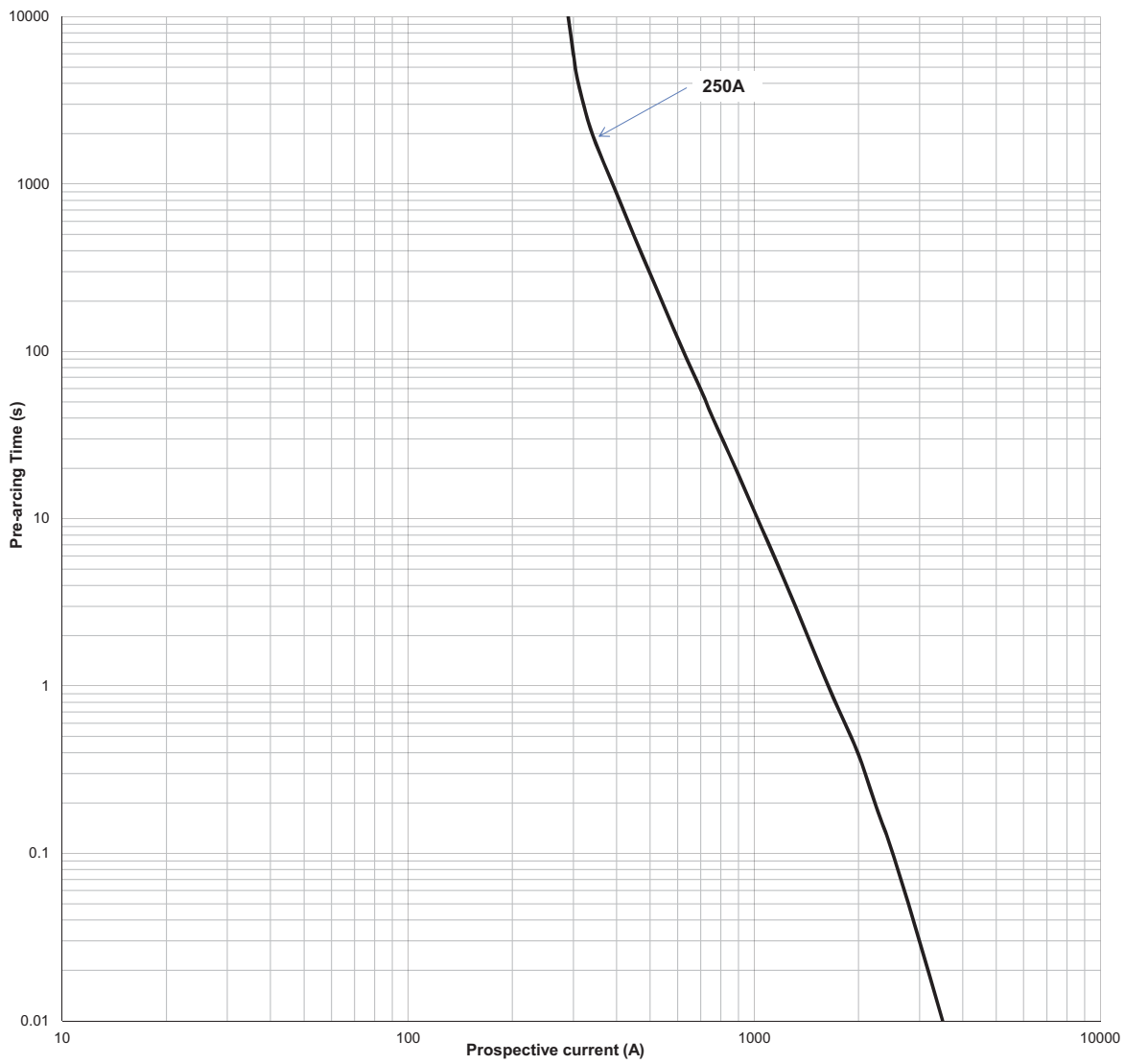

Time-current curves - NH size 3

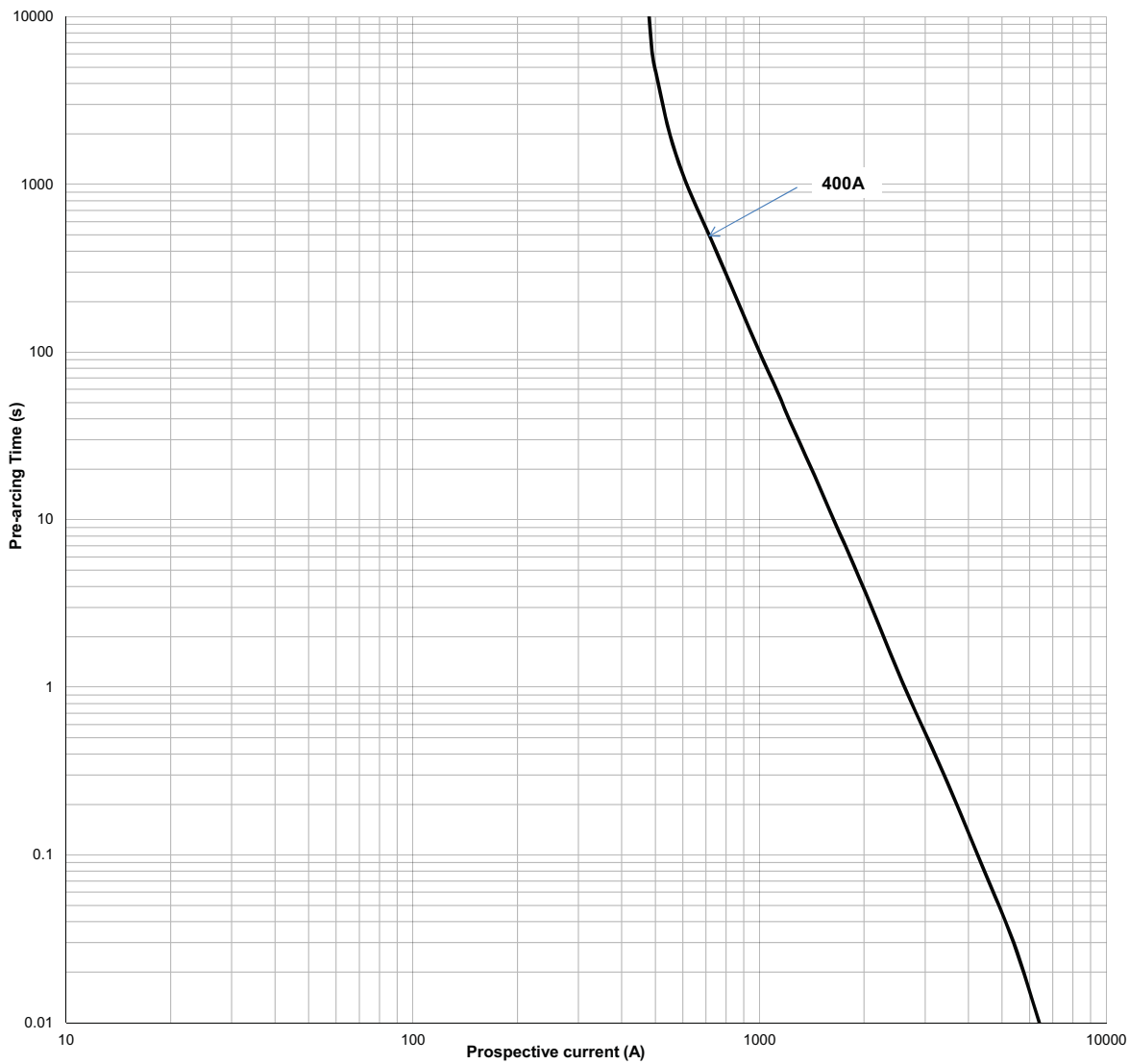

Changes to the products, to the information contained in this document, and to prices are reserved; so are errors or omissions. Only order confirmations and technical documentation by Eaton is binding. Photos and pictures also do not warrant a specific layout or functionality. Their use in whatever form is subject to prior approval by Eaton. The same applies to Trademarks (especially Eaton, Moeller and Cutler-Hammer). The Terms and Conditions of Eaton apply, as referenced on Eaton internet pages and Eaton order confirmations

Eaton's Bussmann Business

Melton Road
Burton-on-the-Wolds
LE12 5TH
United Kingdom
www.bussmann.com

© 2013 Eaton
All Rights Reserved
Printed in UK
Publication No 10152 - BU-SB13925
September 2013

Eaton is a registered trademark.

All other trademarks are property of their respective owners.