

3-port multi-wire lug kit for use on 200 A Compact Circuit Protector and 200/225 A CUBEFuse holders

Catalog no. CCP2-MW2-3

⚠ DANGER

HAZARD OF ELECTRIC SHOCK, EXPLOSION OR ARC FLASH

MAY RESULT IN DEATH OR SERIOUS INJURY

Working on or near energized circuits poses a serious risk of electric shock. De-energize all circuits before installing or servicing this equipment and follow all prescribed safety procedures.

⚠ PELIGRO

RIESGO DE DESCARGA ELÉCTRICA, EXPLOSIÓN O ARCO ELÉCTRICO PUEDE CAUSAR LESIONES GRAVES O INCLUSO LA MUERTE

Trabajar en o cerca de circuitos energizados representa un grave riesgo de descarga eléctrica. Desconecte todos los circuitos antes de realizar alguna instalación o de dar servicio a este equipo y siga todos los procedimientos de seguridad indicados.

⚠ DANGER

RISQUE D'ÉLECTROCUTION, D'EXPLOSION OU D'ARC ÉLECTRIQUE

RISQUE DE MORT OU DE BLESSURES GRAVES

Travailler sur des circuits sous tension ou à proximité pose un risque grave de choc électrique. Mettez tous les circuits hors tension avant d'installer ou d'effectuer l'entretien de cet équipement et suivre toutes les procédures de sécurité prescrites.

Contents

Description	Page
Kit contents	1
Instructions for assembly	2

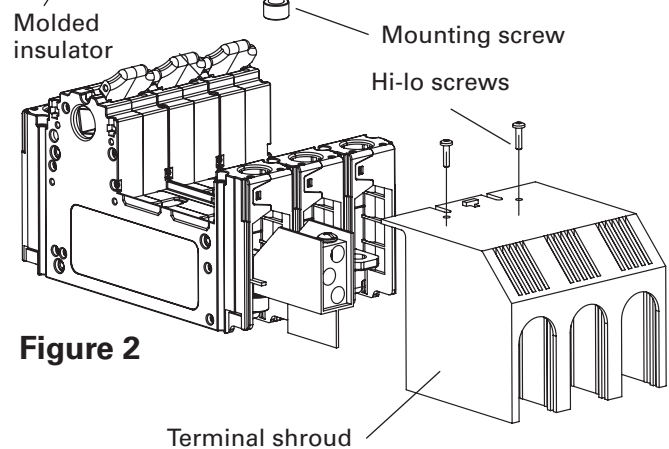
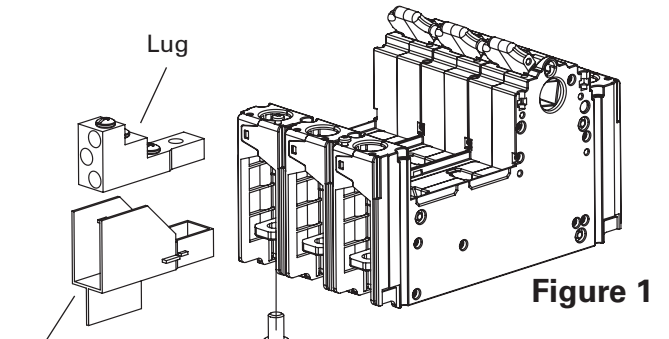

Kit contents

(3) molded insulators, (3) 3-port wire lugs, (3) 5/16-24 mounting screws, (2) #6-19 hi-lo screws, (1) torque label, (1) terminal shroud

Wire range 2-14 AWG (maximum 3) copper or aluminum wires.

This kit is UL Listed (File E64983) for field installation on the loadside of the 200 A Frame Compact Circuit Protector (CCP) and 220/225 A CUBEFuse holders (TCFH_N).

Note: The purpose of these lugs is to distribute power to more than one load and are to be installed only on the loadside.

WARNING:

CONDUCTORS SIZED FOR LOAD CURRENTS LOWER THAN THE FUSE RATING WILL NOT BE PROTECTED BY THE FUSE.

EACH LOAD CONDUCTOR MUST BE PROTECTED BY AN INDIVIDUAL OVERCURRENT PROTECTIVE DEVICE AND MEET ANY ADDITIONAL REQUIREMENTS OF THE NATIONAL ELECTRICAL CODE.

Instructions for assembly

If CCP or CUBEFuse holder is already installed in equipment, it must be removed from equipment for installing this kit. This kit is intended for use only on the loadside only. See Figure 1.

NOTE: Supplied molded insulators must be installed to maintain electrical spacings.

1. Remove and discard existing loadside wire lugs from CCP or CUBEFuse holder, if applicable.
2. Place lug into molded insulator as shown in Figure 1.
3. Place molded insulator and lug on top of the terminal as shown in Figure 1.

NOTE: Use only mounting screws provided with kit. Do not substitute, or electrical spacings may not be met.

4. Install provided mounting screw as shown in Figure 1. Torque mounting screw to 10.8 N•m (95.6 lb-in).
5. Repeat steps 2 through 4 for the remaining poles.
6. Apply torque label to side of CCP or CUBEFuse holder.

The CCP or CUBEFuse holder may be installed into equipment at this time. After installation, mount terminal shroud with hi-lo screws (see Figure 2).

FIELD WIRINGS:

Note: It may not be possible to install the largest conductors in adjacent lug ports due to the wire insulation thickness. Use only connections that allow inserting wires without undue insulation interference between wires at the lug. When fully inserted into the lug, the insulation should be within 1/8 inch of the lug. Strip wires to lengths shown below.

Lug port	Wire strip length (in)	Lug torque N•m (lb-in)
Upper	3/8 to 1/2	
Middle	3/4 to 7/8	7.9 (70)
Lower	1-1/4 to 1-3/8	

Eaton
1000 Eaton Boulevard
Cleveland, OH 44122
Eaton.com

Bussmann Division
114 Old State Road
Ellisville, MO 63021
United States
Eaton.com/bussmannseries

© 2019 Eaton
All Rights Reserved
Printed in USA
Publication No. PUB10690

3A3769
January 2019



These instructions are published solely for information purposes and should not be considered all-inclusive.

If further information is required, consult Application Engineering at 855-287-7626 Monday-Friday from 7:00 a.m. – 5:00 p.m. Central time or email FuseTech@Eaton.com.

Sale of the product shown in this document is subject to terms and conditions outlined in appropriate Bussmann Division selling policies or other contractual agreements between the parties. This document is not intended to and does not enlarge or add to any such contract. The sole source governing the rights and remedies of any purchaser of this equipment is the contract between the purchaser and the Bussmann Division.

NO WARRANTIES, EXPRESSED OR IMPLIED, INCLUDING WARRANTIES OF FITNESS FOR A PARTICULAR PURPOSE OR MERCHANTABILITY, OR WARRANTIES ARISING FROM COURSE OF DEALING OR USAGE OF TRADE, ARE MADE REGARDING THE INFORMATION, RECOMMENDATIONS AND DESCRIPTIONS CONTAINED HEREIN.

In no event will the Bussmann Division be responsible to the purchaser or user in contract, in tort (including negligence), strict liability or otherwise for any special, indirect, incidental or consequential damage or loss whatsoever, including but not limited to damage or loss of equipment use, plant or power system, cost of capital, loss of power, additional expenses in the use of existing power facilities or claims against the purchaser or user by its customers resulting from the use of the information, recommendations and description contained herein.

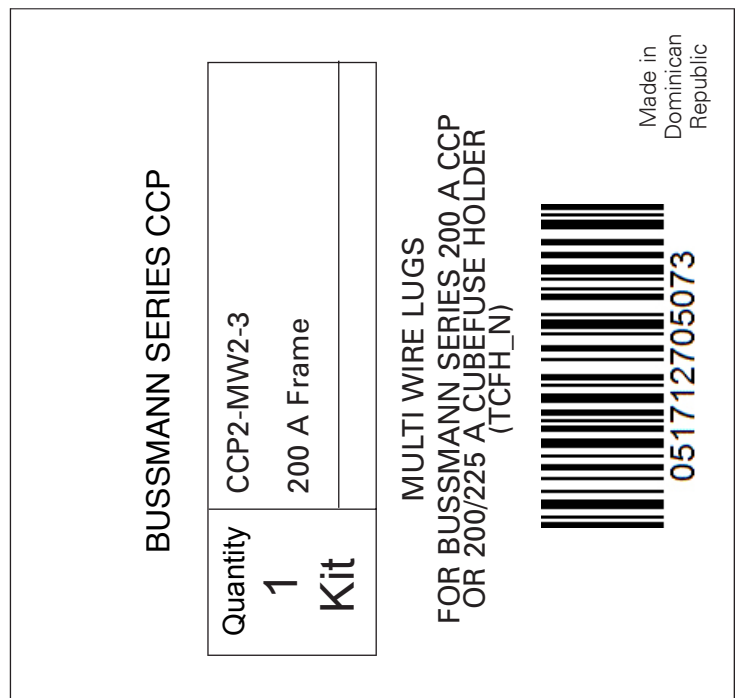

Eaton and Bussmann are valuable trademarks of Eaton in the U.S. and other countries. You are not permitted to use the Eaton trademarks without prior written consent of Eaton.