

**⚠ DANGER**

**HAZARD OF ELECTRIC SHOCK, EXPLOSION OR ARC FLASH**

**MAY RESULT IN DEATH OR SERIOUS INJURY**

Working on or near energized circuits poses a serious risk of electric shock. De-energize all circuits before installing or servicing this equipment and follow all prescribed safety procedures.

**⚠ PELIGRO**

**RIESGO DE DESCARGA ELÉCTRICA, EXPLOSIÓN O ARCO ELÉCTRICO**

**PUEDA CAUSAR LESIONES GRAVES O INCLUSO LA MUERTE**

Trabajar en o cerca de circuitos energizados representa un grave riesgo de descarga eléctrica. Desconecte todos los circuitos antes de realizar alguna instalación o de dar servicio a este equipo y siga todos los procedimientos de seguridad indicados.

**⚠ DANGER**

**RISQUE D'ÉLECTROCUTION, D'EXPLOSION OU D'ARC ÉLECTRIQUE**

**RISQUE DE MORT OU DE BLESSURES GRAVES**

Travailler sur des circuits sous tension ou à proximité pose un risque grave de choc électrique. Mettez tous les circuits hors tension avant d'installer ou d'effectuer l'entretien de cet équipement et suivre toutes les procédures de sécurité prescrites.

**NOTE:** These instructions cover the following catalog numbers:

CCP2-(pole)-200CF  
 CCP2-(pole)-400CF  
 CCD2-3-200  
 CCD2-3-400

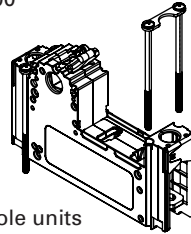

1-pole units

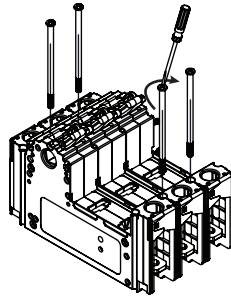

2- and 3-pole units

Locate and mark holes for mounting screws as shown. Drill and tap mounting holes in the back plate for M5 screw, insert supplied mounting screws and torque to 2.3 N•m (20 lb-in).

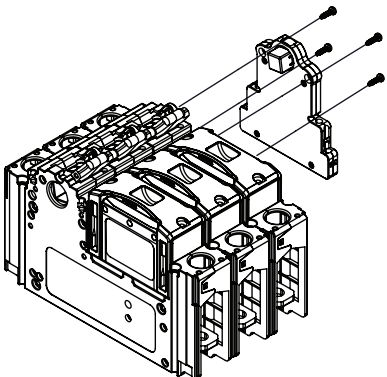

Auxiliary contact (order separately cat. no. CCP2-AUX-S): align shaft on auxiliary contact with switch and insert as shown. Install the four mounting screws.

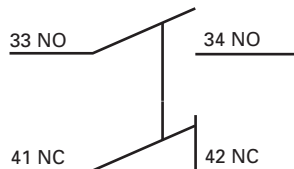

# BUSSMANN SERIES

NOTES:

- Fuses cannot be inserted or extracted when the switch is in the ON position.
- Switches are amp rating rejecting and will not accept a fuse with an amp rating greater than the switch.

Place switch in OFF position.

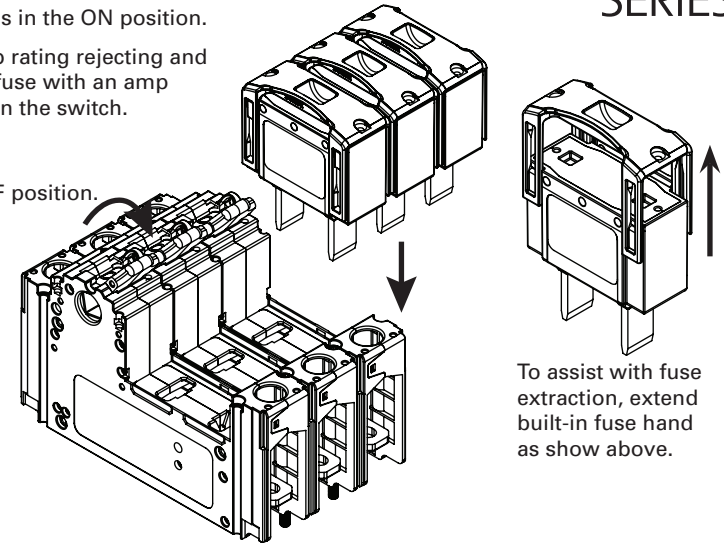

To assist with fuse extraction, extend built-in fuse hand as show above.

Inserting fuses: Place switch in the OFF position. Align fuse blades with switch slots and push in until fully seated. Reverse procedure to extract fuses.

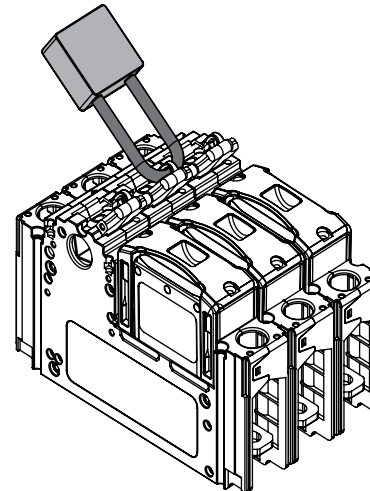

Switch locking feature: place switch in OFF position for lockout/tagout, or ON for lock ON and insert a 1/4" lock.

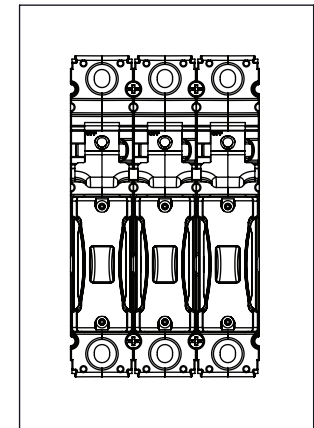

Minimum enclosure size:  
 200 A — 16" x 10" x 8"  
 (405 x 250 x 200 mm)  
 400 A — 24" x 16" x 10"  
 (610 x 405 x 250 mm)

Minimum spacing: 2" (51 mm) over surface, 1" (25 mm) through air.

This table contains information on the various lug kits associated with these switches. Please refer to this table for the allowable wire types, temperature ratings and torque values.

| Lug catalog number    | Lugs per cat. no. | AWG (mm <sup>2</sup> ) | Wire type/temp. | Conductor torque<br>N·m (lb-in) | Lug mounting screw torque<br>N·m (lb-in) |
|-----------------------|-------------------|------------------------|-----------------|---------------------------------|--|
| <b>200 A switches</b> |                   |                        |                 |                                 |  |
| CCP2-L2-1             | 1                 | 350-4 (185-25)         | Cu 75°C         | 20.3 (180)                      | 0.9 (8)                                  |
| CCP2-L2-1A            | 1                 | 350-4 (185-25)         | Cu/Al 75°C      | 28.2 (250)                      | 13.5 (120 lb-in)                         |
| <b>400 A Switches</b> |                   |                        |                 |                                 |  |
| CCP2-L4-1             | 1                 | 500-3 (240-35)         | Cu 75°C         | 42.0 (375)                      | 22.0 (200)                               |
| CCP2-L4B-3            | 3                 | 750-500 (400-240)      | Cu 75°C         | 57.0 (500)                      |  |
| CCP2-L4-1A            | 1                 | 500-3 (240-35)         | Cu/Al 75°C      | 42.0 (375)                      |  |
| CCP2-L4B-3A           | 3                 | 750-500 (400-240)      | Cu/Al 75°C      | 62.0 (550)                      |  |

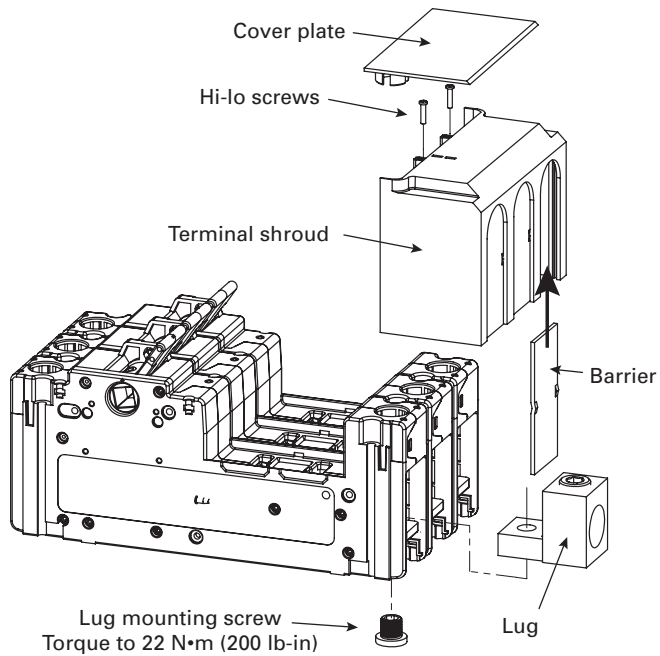

Parts and assembly for lug kit catalog numbers CCP2-L4B-3, and CCP2-L4B-3A for 3-pole 400 amp switches.

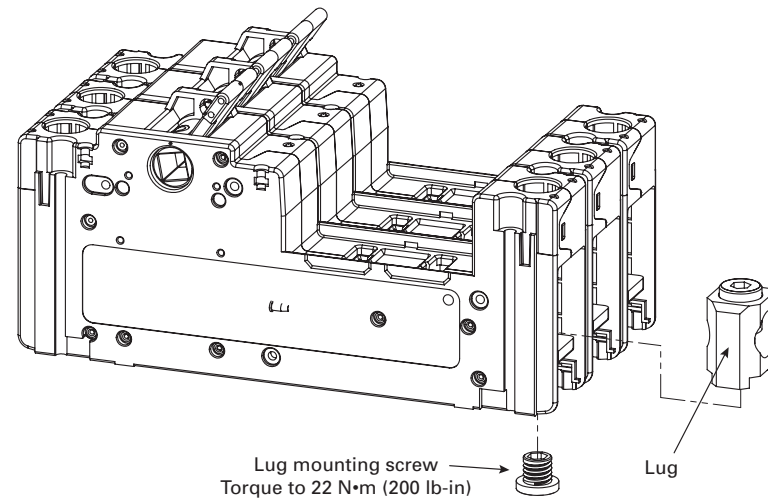

Parts and assembly for lug kit catalog numbers CCP2-L4-1 and CCP2-L4-1A for 400 amp switches.

For a complete installation on 3-pole switches, install the available terminal shroud.

Order catalog number CCP2-TS6-3.