

16A - 80A UL 508 DISCONNECT SWITCHES

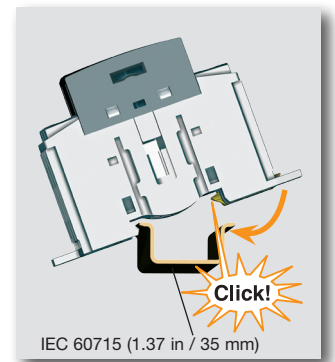

541569C

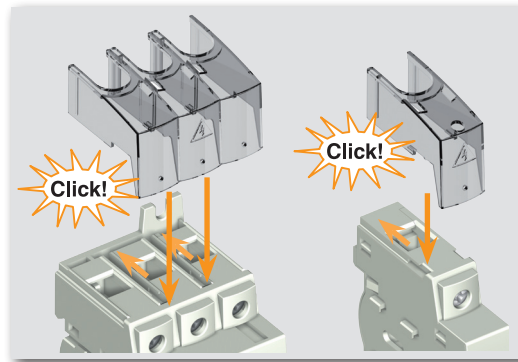
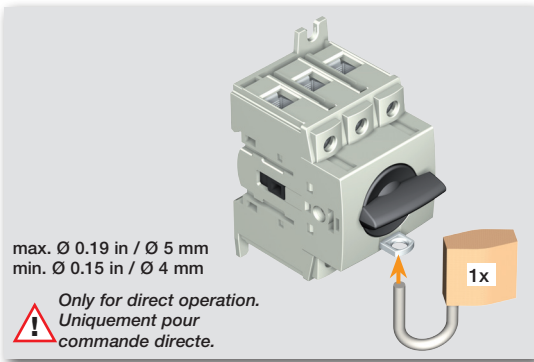
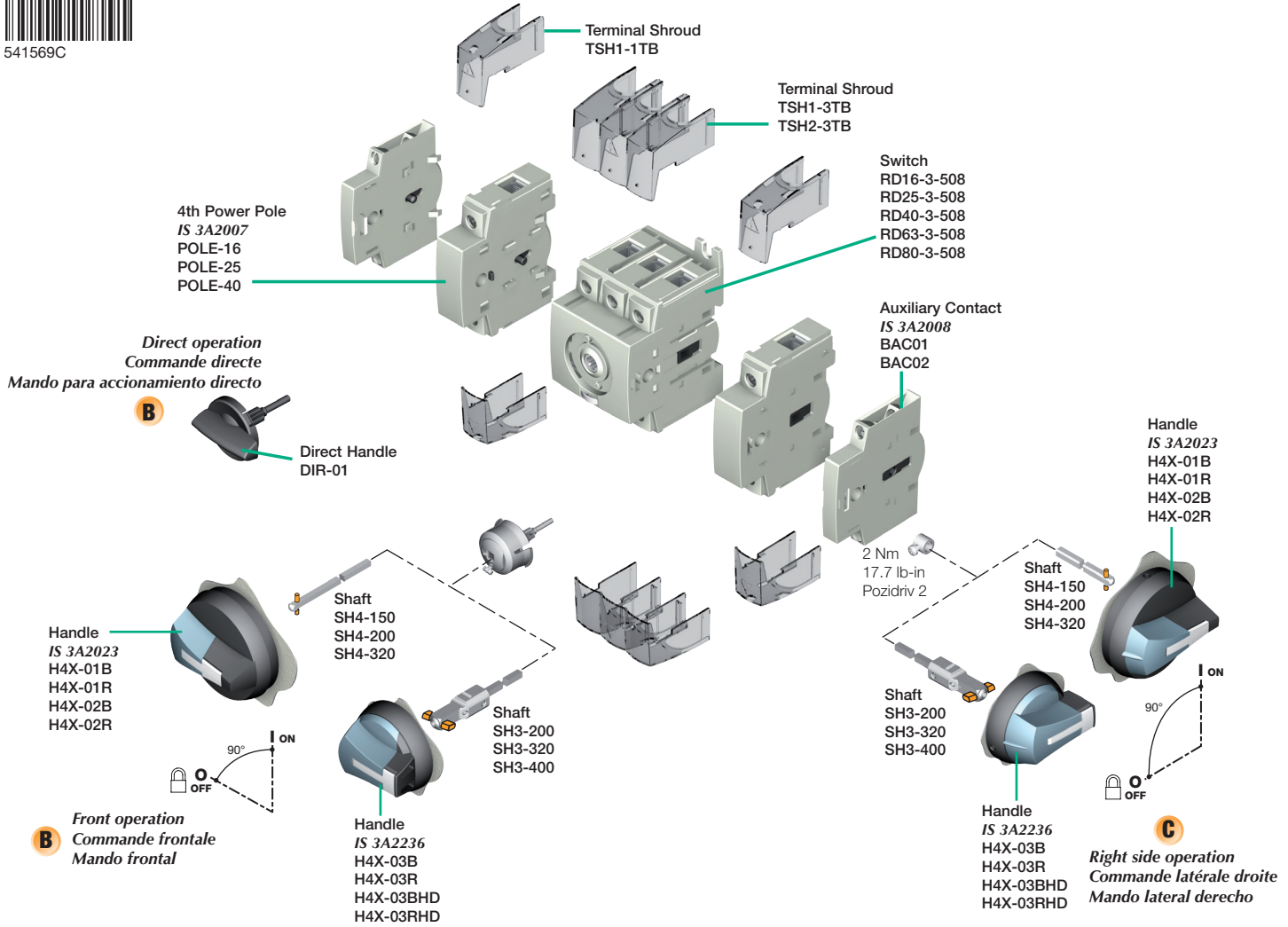

| | 16A to 40A | | 63A - 80A | |
|---|--|----------------------------------|---|----------------------------------|
| | Wire / Câble / Cable | Torque / Couple / Par de apriete | Wire / Câble / Cable | Torque / Couple / Par de apriete |
| Use copper conductors only, 75°C or higher. Flat 6,5 Pozidriv 2 | 1,5 mm ² - 16 mm ² 14 - 4 AWG stranded 14 - 10 AWG solid 2x14 - 2x12 AWG stranded 2x12 AWG solid | 26.5 lb-in / 3 Nm | 2,5 mm ² - 35 mm ² 14 - 1 AWG stranded 14 - 10 AWG solid 2x10 - 2x6 AWG stranded 2x12 AWG solid | 31.1 lb-in / 3,5 Nm |

⚠ DANGER

HAZARDOUS VOLTAGE. This equipment must be installed and serviced only by qualified electrical personnel. Turn off all power supplying this equipment before working on or inside equipment. Always use a properly rated voltage sensing device to confirm power is OFF. Replace all devices, doors, and covers before turning on power to this equipment. **Failure to follow these instructions will result in death or serious injury.**

TENSION DANGEREUSE. L'installation et l'entretien de cet appareil ne doivent être effectués que par du personnel qualifié. Coupez l'alimentation de cet appareil avant d'y travailler. Utilisez toujours un dispositif de détection de tension à valeur nominale approprié pour confirmer que toute alimentation est coupée. Remplacez tous les dispositifs, les portes et les couvercles avant de mettre cet appareil sous tension. **Si ces précautions ne sont pas respectées, cela entraînera la mort ou des blessures graves.**

TENSION PELIGROSA. Solamente el personal de mantenimiento eléctrico especializado deberá instalar y prestar servicios de mantenimiento a este equipo. Desenergice el equipo antes de realizar cualquier trabajo en él. Siempre utilice un dispositivo detector de tensión adecuado para confirmar la desenergización del equipo. Vuelva a colocar todos los dispositivos, las puertas y las cubiertas antes de energizar este equipo. **El incumplimiento de estas precauciones podrá causar la muerte o lesiones serias.**

⚠ CAUTION

The opening of the branch-circuit protective device may be an indication that a fault has been interrupted. To reduce the risk of fire or electric shock, current-carrying parts and other components of the controller should be examined and replaced if damaged.

Le déclenchement du dispositif de protection des dérives peut signifier qu'un courant de défaut a été interrompu. Pour réduire le risque d'incendie ou de choc électrique, les pièces porteuses de courant et les autres composants de la commande doivent être vérifiés et remplacés s'ils sont endommagés.

La activación del dispositivo de protección frente a derivaciones puede significar que se ha interrumpido una corriente de fallo. Para reducir el riesgo de incendio o de choque eléctrico, las piezas portadoras de corriente y demás componentes del pedido deberán comprobarse y sustituirse en caso de que se encuentren dañados.

Direct operation
Commande directe
Mando para accionamiento directo

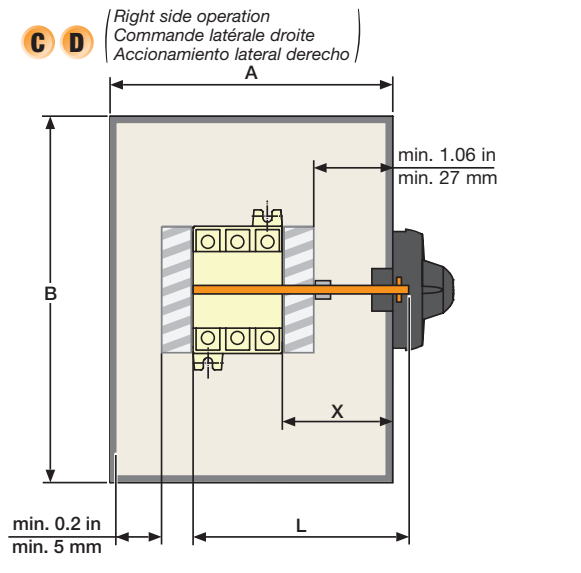
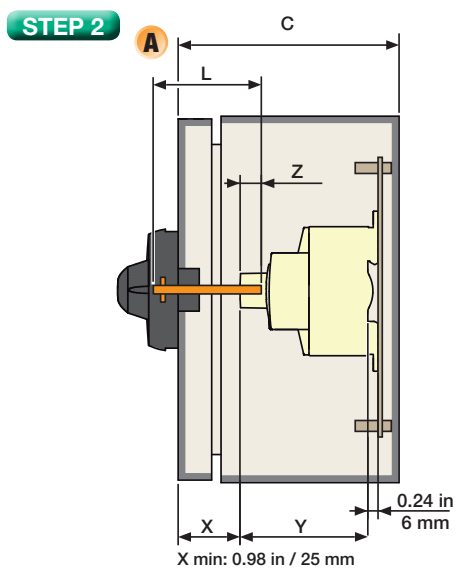
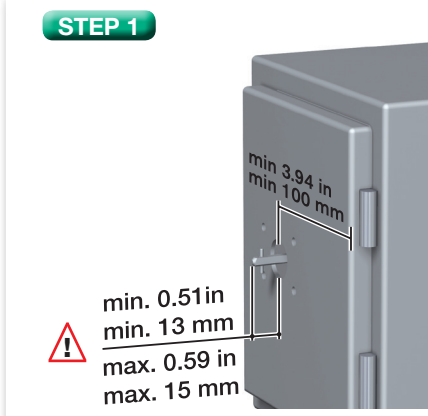
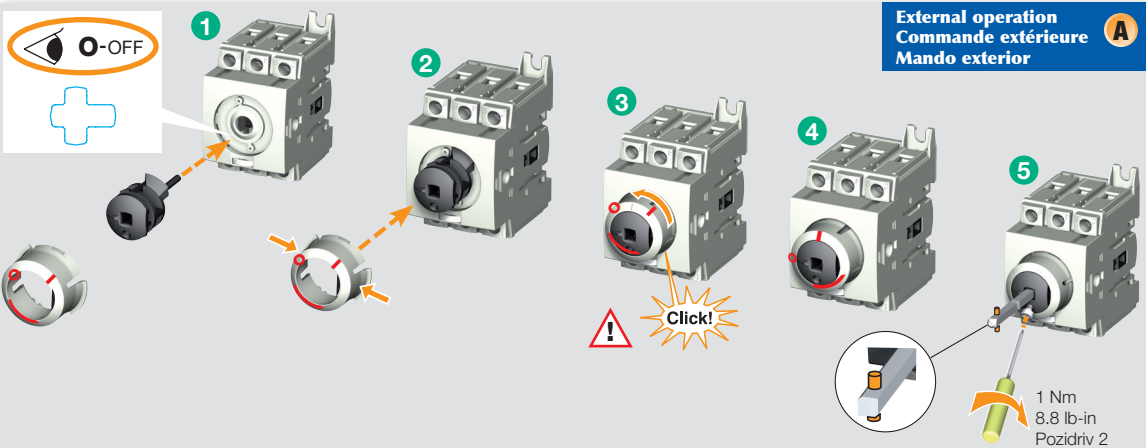
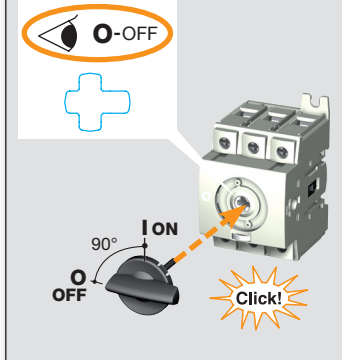

| | A | C D | E | |
|----------|--|--|-------------------|-------------------|
| | M16 to M40 - M CD63 M63 - M80 - M CD100 | M16 to M40 - M CD63 M63 - M80 - M CD100 | min. | max. |
| Type S00 | L = X + 1.26 in L = X + 32 mm | L = X + 2.36 in L = X + 60 mm | 0.51 in / 13 mm | 0.59 in / 15 mm |
| Type S01 | L = X + 1.26 in L = X + 38.5 mm | L = X + 2.61 in L = X + 66.5 mm | 0.68 in / 17.5 mm | 0.84 in / 21.5 mm |

Switch / Interrupteur / Interruptor

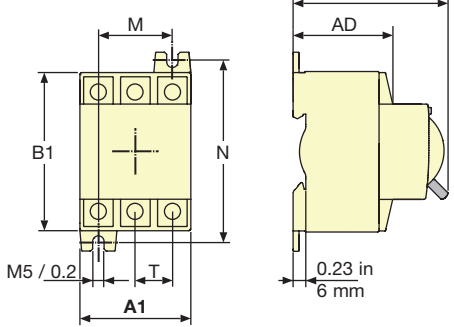

Add. Pole
Pole additionnel
Polo adicional

Aux. Contacts
Contacts aux.
Contactos auxiliares

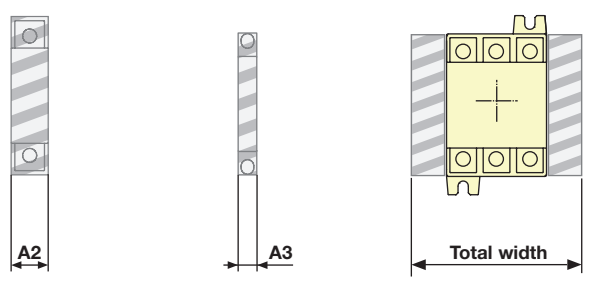

Total width = A1 + x A2 + y A3
 if x = 0 y = 2 max
 if x = 1 y = 2 max
 if x = 2 y = 2 max

Dual dimensions in/mm
 Double dimensions in/mm
 Doble dimensiones in/mm

| | 16A to 40A | | 63A - 80A | |
|--------|----------------------|------------------|--------------------|--------------------|
| | in | mm | in | mm |
| A | 6 | 152 | 8 | 203 |
| A1 | 1.77 (2.5 x 0.70) | 45 (2.5 x 18) | 2.06 (3 x 0.68) | 52.5 (3 x 17.5) |
| A2 | 0.59 | 15 | 0.68 | 17.5 |
| A3 | 0.34 | 8.8 | 0.34 | 8.8 |
| AD | 1.90 | 48.5 | 1.90 | 48.5 |
| B | 8 | 203 | 10 | 253 |
| B1 | 2.67 | 68 | 3 | 76 |
| C | 4 | 102 | 4 | 102 |
| H | 2.95 | 75 | 2.95 | 75 |
| T | 0.59 | 15 | 0.68 | 17.5 |
| N | 2.95 | 75 | 3.35 | 85 |
| M | 1.18 | 30 | 1.38 | 35 |
| Y | 2.95 | 75 | 2.95 | 75 |
| Z min. | 0.47 | 12 | 0.47 | 12 |
| Z max. | 0.67 | 17 | 0.67 | 17 |