

⚠ DANGER

HAZARD OF ELECTRIC SHOCK, EXPLOSION OR ARC FLASH
MAY RESULT IN DEATH OR SERIOUS INJURY

Working on or near energized circuits poses a serious risk of electric shock. De-energize all circuits before installing or servicing this equipment and follow all prescribed safety procedures.



⚠ PELIGRO

RIESGO DE DESCARGA ELÉCTRICA, EXPLOSIÓN O ARCO ELÉCTRICO
PUEDO CAUSAR LESIONES GRAVES O INCLUSO LA MUERTE

Trabajar en o cerca de circuitos energizados representa un grave riesgo de descarga eléctrica. Desconecte todos los circuitos antes de realizar alguna instalación o de dar servicio a este equipo y siga todos los procedimientos de seguridad indicados.



⚠ DANGER

RISQUE D'ÉLECTROCUTION, D'EXPLOSION OU D'ARC ÉLECTRIQUE
RISQUE DE MORT OU DE BLESSURES GRAVES

Travailler sur des circuits sous tension ou à proximité pose un risque grave de choc électrique. Mettez tous les circuits hors tension avant d'installer ou d'effectuer l'entretien de cet équipement et suivre toutes les procédures de sécurité prescrites.

CCP2-MW1-3 multi-wire lug kit (30 and 60 A switches only)

Contents: Three (3) 3-port lugs, three (3) terminal shrouds

Required tools: Wire strippers, Phillips or blade screwdriver, 1/8" Allen wrench

These multi-wire lugs can be installed on the lineside or loadside of these switch catalog numbers.

CCP2-(pole)-30CC	CCP2-(pole)-30M	CCP2-1-DCC	CCP2-1-DCM
CCP2R-(pole)-30CC	CCP2R-(pole)-30M	CCP2RL-(pole)-30CC	CCP2RL-(pole)-30M
CCP2S-(pole)-30CC	CCP2S-(pole)-30M	CCP2SL-(pole)-30CC	CCP2SL-(pole)-30M
CCP2-(pole)-30CF	CCP2R-(pole)-30CF	CCP2RL-(pole)-30CF	CCP2S-(pole)-30CF
CCP2SL-(pole)-30CF	CCP2-(pole)-60CF	CCP2R-(pole)-60CF	CCP2RL-(pole)-60CF
CCP2S-(pole)-60CF	CCP2SL-(pole)-60CF	CCD2-(pole)-30	CCD2R-(pole)-30
CCD2RL-(pole)-30	CCD2S-(pole)-30	CCD2SL-(pole)-30	CCD2-(pole)-60
CCD2R-(pole)-60	CCD2RL-(pole)-60	CCD2S-(pole)-60	CCD2SL-(pole)-60

Note: Installing these multi-wire lugs and shrouds prohibits installing the CCP2-PLC-IND fuse monitor.

Installation

- Step 1. Consult the conductor information table for the permitted wire types, AWG sizes, classes, quantity per port and terminal screw torque values.
- Step 2. Refer to the wire insulation strip lengths table and strip back the wire's insulation to the appropriate length for the lug port into which it will be installed.
- Step 3. Fully insert the wire(s) into the lug port and torque the terminal screw to the appropriate value as shown in the conductor table (wire connections are more easily made by installing the wires for port 3 first, then 2 and 1).
- Step 4. Repeat steps 2 and 3 for all wires on each lug to be installed.
- Step 5. Insert the lug into the switch box lug terminal as shown and torque to 4.52 N•m (40 lb-in).
- Step 6. Align a finger-safe shroud with the dovetail on the switch as shown and press down until the shroud is fully seated and "clicks" over the lug. Repeat shroud installation for all other switch poles, if applicable.

Conductor information

75°C Cu/Al solid or stranded wire as detailed below.

Type	AWG range	Class	Quantity	Torque N•m (lb-in)
Cu/Al	4-6	Stranded, Class B/C	Single	3.95 (35)
	8			2.82 (25)
Cu	10-14	Stranded, Class B/C	Single/dual*	2.26 (20)
	10-14	Solid	Single	2.26 (20)
	8	UL ferrule, Class B to K	Single/twin†	2.82 (25)
10-14	2.26 (20)			

* Dual wire to be same size and type.

† Two stranded conductors placed in one UL Listed twin ferrule.

Wire insulation strip lengths

Strip back wire insulation to the lengths as indicated in the illustration and the table below.

Lug port	Strip wire insulation back (inch)
1	11/16
2	1-1/8
3	1-9/16

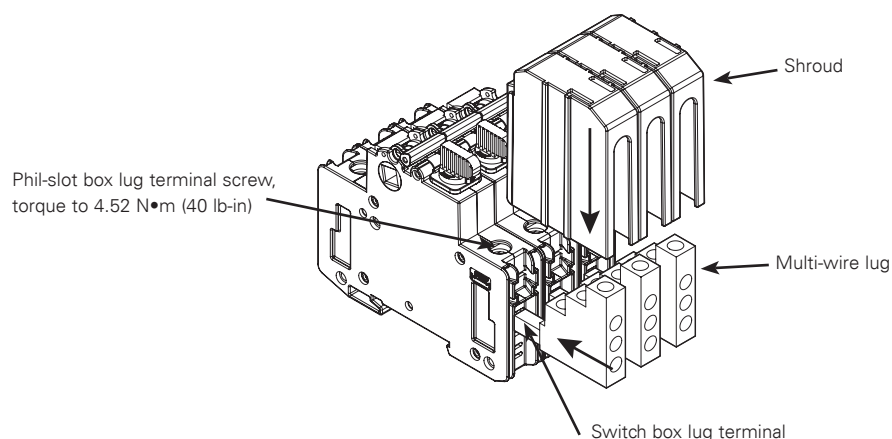
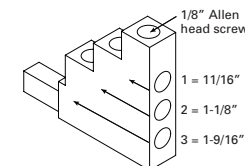



DANGER

HAZARD OF ELECTRIC SHOCK, EXPLOSION OR ARC FLASH
MAY RESULT IN DEATH OR SERIOUS INJURY

Working on or near energized circuits poses a serious risk of electric shock. De-energize all circuits before installing or servicing this equipment and follow all prescribed safety procedures.



PELIGRO

RIESGO DE DESCARGA ELÉCTRICA, EXPLOSIÓN O ARCO ELÉCTRICO
PUEDA CAUSAR LESIONES GRAVES O INCLUSO LA MUERTE

Trabajar en o cerca de circuitos energizados representa un grave riesgo de descarga eléctrica. Desconecte todos los circuitos antes de realizar alguna instalación o de dar servicio a este equipo y siga todos los procedimientos de seguridad indicados.



DANGER

RISQUE D'ÉLECTROCUTION, D'EXPLOSION OU D'ARC ÉLECTRIQUE
RISQUE DE MORT OU DE BLESSURES GRAVES

Travailler sur des circuits sous tension ou à proximité pose un risque grave de choc électrique. Mettez tous les circuits hors tension avant d'installer ou d'effectuer l'entretien de cet équipement et suivre toutes les procédures de sécurité prescrites.

CCP2-MW1-6 multi-wire lug kit (100 A switches only)

Contents: Three (3) 6-port lugs, three (3) terminal shrouds

Required tools: Wire strippers, Phillips or blade screwdriver, 1/8" Allen wrench

These multi-wire lugs can be installed on the lineside or loadside of these switch catalog numbers.

CCP2-(pole)-100CF	CCP2R-(pole)-100CF	CCP2RL-(pole)-100CF	CCP2S-(pole)-100CF
CCP2SL-(pole)-100CF	CCD2-(pole)-100	CCD2R-(pole)-100	CCD2RL-(pole)-100
CCD2S-(pole)-100	CCPD2SL-(pole)-100		

Note: Installing these multi-wire lugs and shrouds prohibits installing the CCP2-PLC-100 fuse monitor.

Installation

- Step 1. Consult the conductor information table for the permitted wire types, AWG sizes, classes, quantity per port and terminal screw torque values.
- Step 2. Refer to the wire insulation strip lengths table and strip back the wire's insulation to the appropriate length for the lug port into which it will be installed.
- Step 3. Fully insert the wire(s) into the lug port and torque the terminal screw to the appropriate value as shown in the conductor table (wire connections are more easily made by installing the wires for port 3 first, then 2 and 1).
- Step 4. Repeat steps 2 and 3 for all wires on each lug to be installed.
- Step 5. Insert the lug into the switch box lug terminal as shown and torque to 5.1 N•m (45 lb-in).
- Step 6. Align a finger-safe shroud with the dovetail on the switch as shown and press down until the shroud is fully seated and "clicks" over the lug. Repeat shroud installation for all other switch poles, if applicable.
- Step 6a. **Note on 100 A switches:** When installing shrouds on the lineside, trim off the shroud bottoms so they fully seat in their dovetails. See callout in illustration.

Conductor information

75°C Cu/Al solid or stranded wire as detailed below.

Type	AWG range	Class	Quantity	Torque N•m (lb-in)
Cu/Al	4-6	Stranded, Class B/C	Single	3.95 (35)
	8			2.82 (25)
	10-14	Stranded, Class B/C	Single/dual*	2.26 (20)
Cu	10-14	Solid	Single	2.26 (20)
	8	UL ferrule, Class B to K	Single/twin†	2.82 (25)
	10-14			2.26 (20)

* Dual wire to be same size and type.

† Two stranded conductors placed in one UL Listed twin ferrule.

Wire insulation strip lengths

Strip back wire insulation to the lengths as indicated in the illustration and the table below.

Lug port	Strip wire insulation back (inch)
1	11/16
2	1-1/8
3	1-9/16

