

CCP2-H4X-__ selector and pistol handles for use with 8 mm shafts

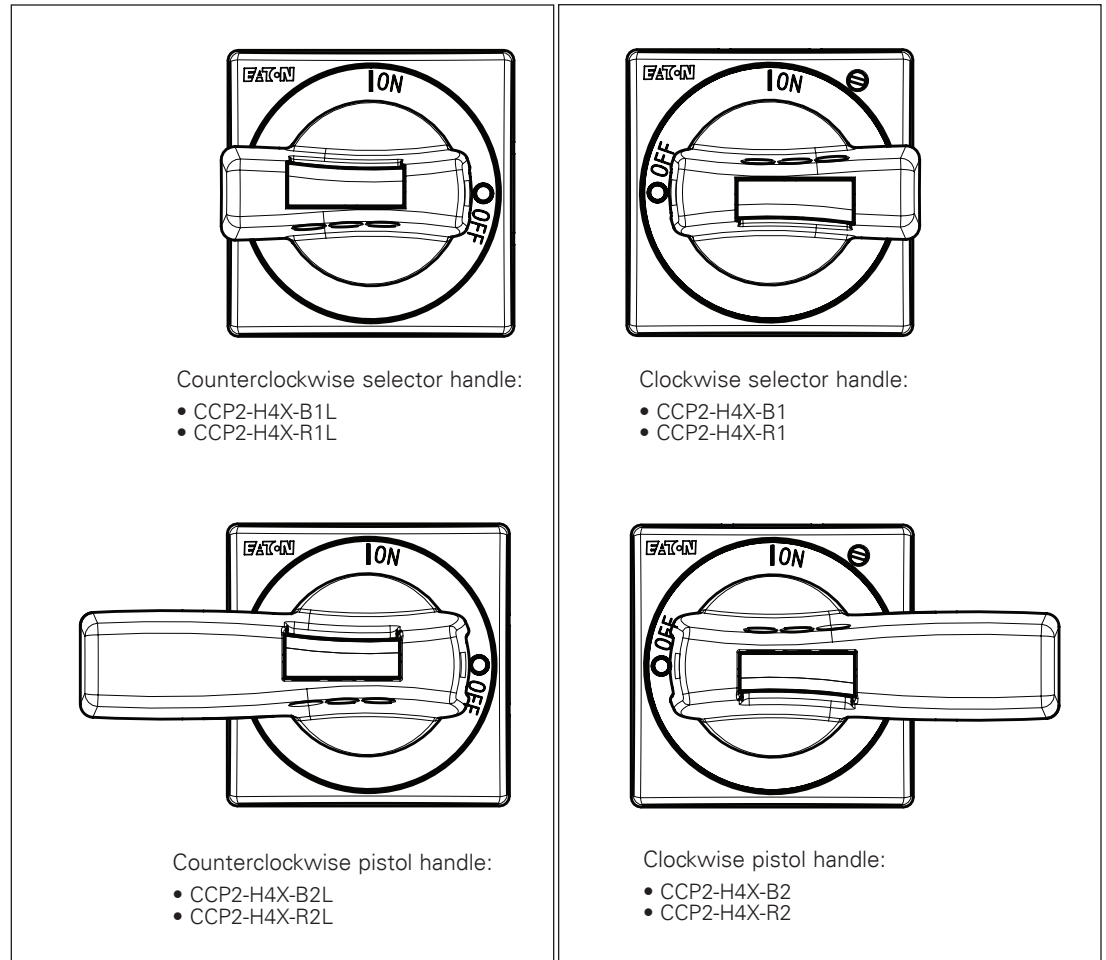

For left side operation only

For front and right side operation only

These instructions cover the installation procedures specific to the catalog numbers shown above. Please review the switch and switch handle applications table on page 2 to ensure the handle in this kit can be installed on your specific Compact Circuit Protector (CCP) switch.

For complete installation, customers must supply one of the following 8 mm square shafts (catalog numbers):

- CCP2-SH1-290 (11.5"/290 mm)
- CCP2-SH1-490 (19.3"/490 mm)

Switch and switch handle applications

Please review the chart below to ensure your switch is compatible with the handle contained in this kit. Shafts are not included and must be purchased separately.

If you have this CCP catalog number	Description	Use any of these handle catalog numbers (description)	With either of these shaft catalog numbers
CCP2R-(pole)-30CC	Right front rotary, clockwise operated switch		
CCP2R-(pole)-30M			
CCP2R-(pole)-30CF			
CCP2R-(pole)-60CF			
CCP2R-(pole)-100CF			
CCD2R-(pole)-30			
CCD2R-(pole)-60			
CCD2R-(pole)-100			
CCP2RL-(pole)-30CC	Left front rotary, clockwise operated switch	<ul style="list-style-type: none"> • CCP2-H4X-B1 (selector handle/black/grey) • CCP2-H4X-R1 (selector handle/red/yellow) • CCP2-H4X-B2 (pistol handle/black/grey) • CCP2-H4X-R2 (pistol handle/red/yellow) 	
CCP2RL-(pole)-30M			
CCP2RL-(pole)-30CF			
CCP2RL-(pole)-60CF			
CCP2RL-(pole)-100CF			
CCD2RL-(pole)-30			
CCD2RL-(pole)-60			
CCD2RL-(pole)-100			
CCP2S-(pole)-30CC	Right side rotary, clockwise operated switch		<ul style="list-style-type: none"> • CCP2-SH1-290 (11.5"/290 mm) • CCP2-SH1-490 (19.3"/490 mm)
CCP2S-(pole)-30M			
CCP2S-(pole)-30CF			
CCP2S-(pole)-60CF			
CCP2S-(pole)-100CF			
CCD2S-(pole)-30			
CCD2S-(pole)-60			
CCD2S-(pole)-100			
CCP2SL-(pole)-30CC	Left side rotary, counterclockwise operated switch	<ul style="list-style-type: none"> • CCP2-H4X-B1L (selector handle/black/grey) • CCP2-H4X-R1L (selector handle/red/yellow) • CCP2-H4X-B2L (pistol handle/black/grey) • CCP2-H4X-R2L (pistol handle/red/yellow) 	
CCP2SL-(pole)-30M			
CCP2SL-(pole)-30CF			
CCP2SL-(pole)-60CF			
CCP2SL-(pole)-100CF			
CCD2SL-(pole)-30			
CCD2SL-(pole)-60			
CCD2SL-(pole)-100			

Handle kit contents

Before proceeding, review the kit contents with the parts listed below to be sure all necessary components are at hand. Contact your supplier if any parts are missing.

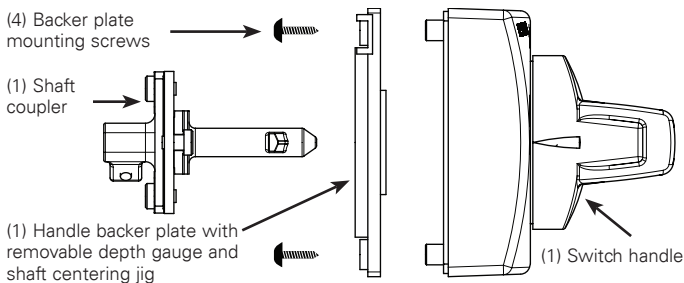

Required tools

- Measuring tape/ruler
- Pencil/felt tip pen
- 2 mm Allen wrench (selector handle only)
- 2.5 mm Allen wrench (pistol handles only)
- 3 mm Allen wrench
- Z2/#2 Phillips head screwdriver
- Straight blade screwdriver
- Needle nose pliers
- 40 mm knockout punch or hole saw
- 8 mm drill bit for metal
- Drill
- Utility knife
- Hacksaw
- Metal file
- Center punch
- Hammer

	⚠ DANGER
	<p>HAZARD OF ELECTRIC SHOCK, EXPLOSION OR ARC FLASH</p> <p>MAY RESULT IN DEATH OR SERIOUS INJURY</p> <p>Working on or near energized circuits poses a serious risk of electric shock. De-energize all circuits before installing or servicing this equipment and follow all prescribed safety procedures.</p>

	⚠ PELIGRO
	<p>RIESGO DE DESCARGA ELÉCTRICA, EXPLOSIÓN O ARCO ELÉCTRICO</p> <p>PUEDA CAUSAR LESIONES GRAVES O INCLUSO LA MUERTE</p> <p>Trabajar en o cerca de circuitos energizados representa un grave riesgo de descarga eléctrica. Desconecte todos los circuitos antes de realizar alguna instalación o de dar servicio a este equipo y siga todos los procedimientos de seguridad indicados.</p>

	⚠ DANGER
	<p>RISQUE D'ÉLECTROCUTION, D'EXPLOSION OU D'ARC ÉLECTRIQUE</p> <p>RISQUE DE MORT OU DE BLESSURES GRAVES</p> <p>Travailler sur des circuits sous tension ou à proximité pose un risque grave de choc électrique. Mettez tous les circuits hors tension avant d'installer ou d'effectuer l'entretien de cet équipement et suivre toutes les procédures de sécurité prescrites.</p>

1.1 Qualified person

For the purpose of this instruction manual, a qualified person:

- (a) is familiar with the subject equipment and the hazards involved with their application, use, administration and maintenance.
- (b) is trained and authorized to de-energize, clear, ground, and tag circuits and equipment in accordance with established safety practices.
- (c) is trained in the proper care and use of personal protective equipment such as rubber gloves, hard hat, safety glasses or face shields, arc-flash clothing, etc., in accordance with established safety practices.
- (d) is trained to render first aid.
- (e) has received safety training to recognize and avoid the hazards involved.
- (f) has the skills and knowledge pertaining to the construction and operation of this equipment and its installation.

IMPORTANT: These procedures do not claim to cover all possible details or variations encountered with the installation of these selector and pistol handles, nor do they provide for all possible conditions that may be encountered. If further information is desired or needed to address any particular issue not covered in this document, contact your Bussmann series product representative. The information in this document does not relieve the user from exercising good judgment, nor from using sound safety practices.

Note: Because Eaton has a policy of continuous product improvement, we reserve the right to change design specifications without notice. Should a conflict arise between the general information in this document and the contents of drawings or supplementary material, or both, the latter shall take precedence. For the latest version of this instruction manual, download Publication No. 3A3695 from Eaton.com/bussmannseries.

2.1 Safety concerns

This installation manual is not comprehensive. It is assumed the installer will follow established safety procedures for working in an electrical environment. For more information on safety precautions and procedures, consult the following websites:

- National Fire Protection Association (NFPA®) www.nfpa.org
- Underwriters Laboratories (UL®) www.ul.com
- National Electrical Mfgs. Association (NEMA®) www.nema.org
- American National Standards Association (ANSI®) www.ansi.org
- Institute of Electrical and Electronics Engineers (IEEE®) www.ieee.org

Contents

Mounting location/handle rotation	Page
--	-------------

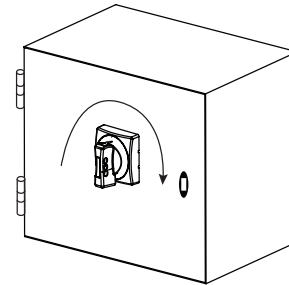

Panel front/clockwise handle rotation	4
--	----------

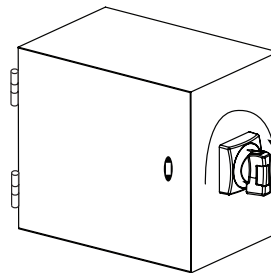

Right panel side/clockwise rotation	7
--	----------

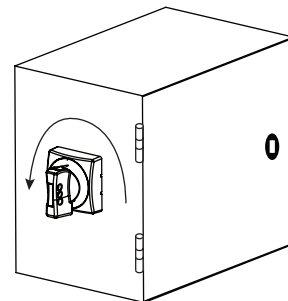

Left panel side/counterclockwise rotation	10
--	-----------

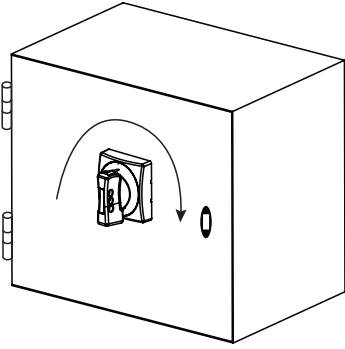

Front clockwise handle operation and installation

The following applies to all clockwise operating selector and pistol switch handles. Illustrations are of the selector handle, but apply equally to pistol handle versions.

Procedures for clockwise handle catalog numbers:

- CCP2-H4X-B1 (selector)
- CCP2-H4X-R1 (selector)
- CCP2-H4X-B2 (pistol)
- CCP2-H4X-R2 (pistol)

For installation with switch catalog numbers:

- CCP2R-(pole)-30CC
- CCP2R-(pole)-30M
- CCP2R-(pole)-30CF
- CCP2R-(pole)-60CF
- CCP2R-(pole)-100CF
- CCD2R-(pole)-30
- CCD2R-(pole)-60
- CCD2R-(pole)-100
- CCP2RL-(pole)-30CC
- CCP2RL-(pole)-30M
- CCP2RL-(pole)-30CF
- CCP2RL-(pole)-60CF
- CCP2RL-(pole)-100CF
- CCD2RL-(pole)-30
- CCD2RL-(pole)-60
- CCD2RL-(pole)-100

And either shaft catalog numbers:

- CCP2-SH1-290
- CCP2-SH1-490

Switch operating modes

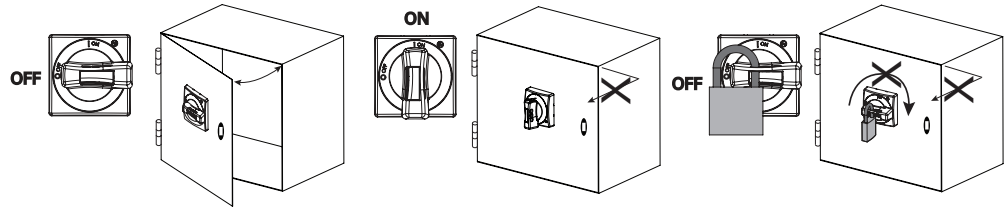

Handle interlock defeat operation

To be performed only by qualified personnel.

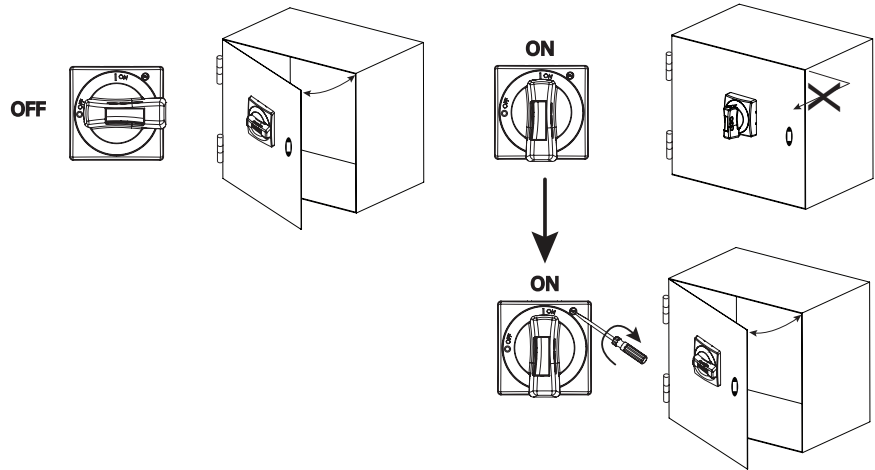

Handle lock ON operation

Note: NOT to be utilized when switch is applied as a means for emergency stop.

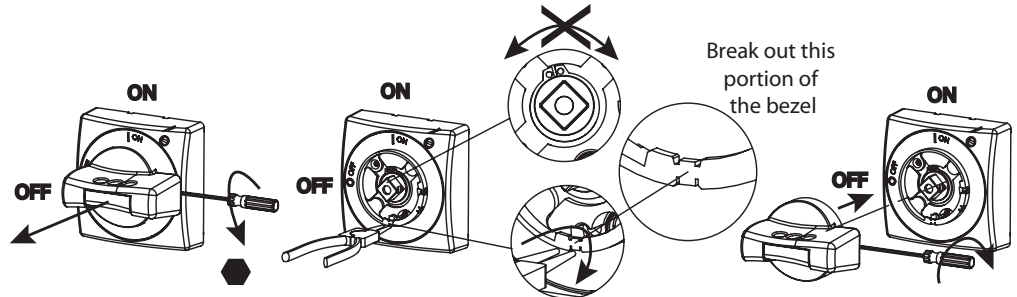

2 mm Allen wrench (selector handles) 2.5 mm Allen wrench (pistol handles) 3 N·m (27 lb-in)

To enable the handle's lock ON feature:

- Use a 2 mm (selector handle) or 2.5 mm (pistol handle) Allen wrench to loosen the setscrew and remove the handle from the handle base as shown.
- Using needle nose pliers, break off the retaining stop on the switch handle bezel as shown.
- Place handle back onto the handle base and tighten the setscrew.

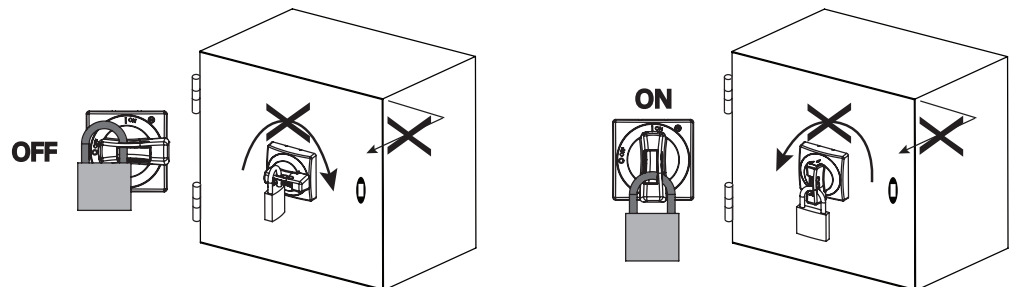

Clockwise handle installation for left or right front rotary operated switches

Applies to selector and pistol handles

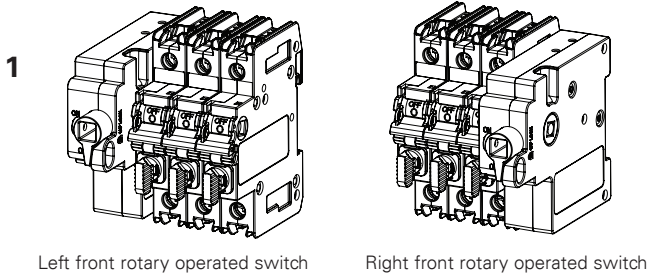

Step 1: With switch mounted on a 35 mm DIN-Rail and in the OFF position, fully insert switch shaft and lightly tighten the setscrew using a 3 mm Allen wrench. Note the shaft is keyed so that it can only be inserted one way.

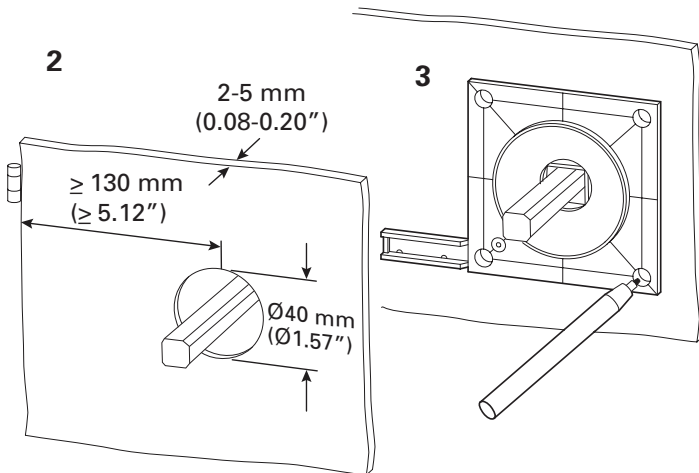

Step 2: Locate shaft's center on the door when closed (shaft is perpendicular to the plane of the door). Note minimum distance from the enclosure door's hinged side to shaft center as shown. If distance is less than 130 mm (5.12"), remount switch in a position that will conform to this minimum distance requirement. Then drill/punch a 40 mm (1.57") hole as shown and remove any burrs that may result from the drilling/punching process. Failure to remove burrs may impair the handle's lock OFF/lock ON function.

Note: Be careful to not distort the door's surface. Doing so may compromise the handle's NEMA 4X seal or impair the handle's lock OFF/lock ON function.

Step 3: With door closed and latched, and switch shaft extending through the enclosure, place the handle backer plate onto the shaft as shown and fully seat backer plate into the hole. Align backer plate horizontally and vertically with the door and mark the centers for the four mounting holes as shown.

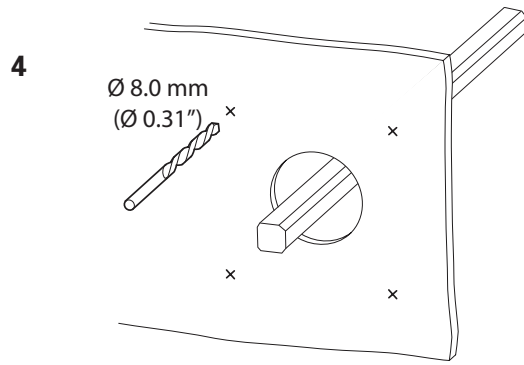

Step 4: Center punch and drill the four backer plate mounting holes using a 8.0 mm (0.31") bit as shown.

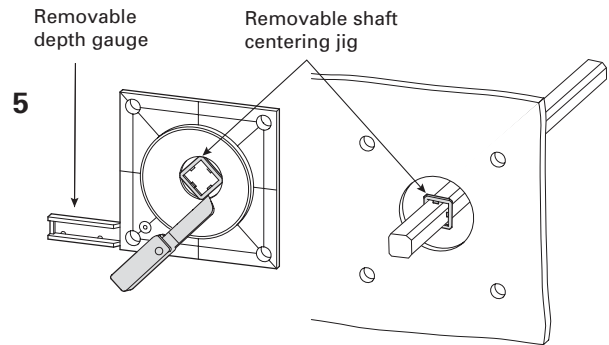

Step 5: Use a utility knife to cut and free the shaft centering jig from the backer plate and place it on the shaft as shown.

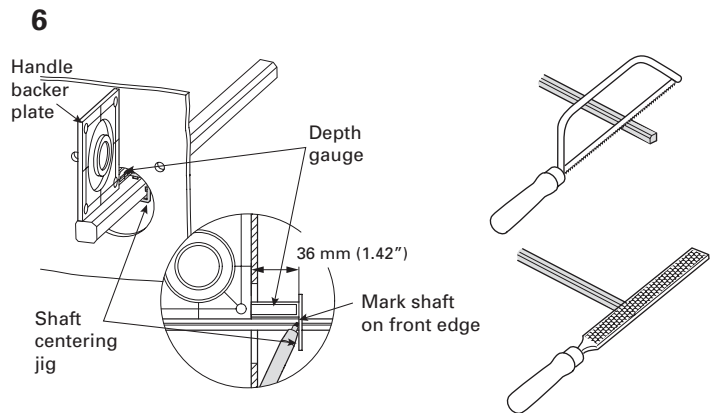

Step 6: Close and latch the enclosure door. Place the handle backer plate against the enclosure door as shown and push the centering jig (now cut free and on the shaft) back until the edge of the handle backer plate is flush with the door.

Open enclosure door and use a pencil or felt tip pen to mark the shaft on the front edge of the centering jig as shown. This is where the shaft is to be cut.

Loosen shaft setscrew on the switch, remove the shaft and cut to length where marked. File off any burrs on the cut end as shown.

Note: To ensure proper fit, make a square cut on the shaft.

7

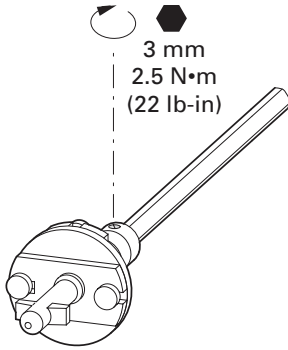

Step 7: Fully insert the shaft back into the switch making sure its indexing corner (largest flat on the shaft) is in the upper left corner of the switch shaft hole. Torque setscrew to 2.5 N•m (22 lb-in) using 3 mm Allen wrench. Place shaft coupler on the shaft as shown and torque setscrew to 2.5 N•m (22 lb-in) using 3 mm Allen wrench. Note the shaft is indexed so the shaft coupler can only be inserted one way.

8

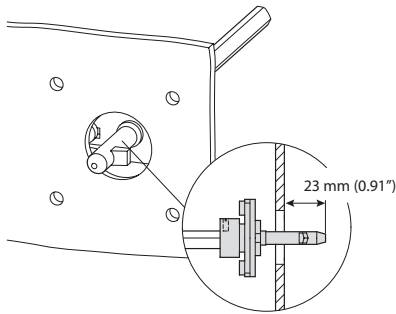

Step 8: Close and latch door. Check the distance the shaft coupler extends beyond the door's front as shown. If extension is too great, recut shaft accordingly and reinstall. If too short, install another shaft per previous instructions.

9

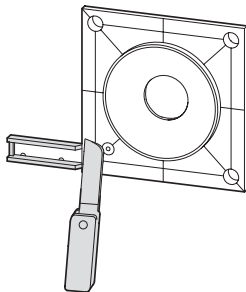

Step 9: Prepare the handle backer plate for mounting by removing the depth gauge as shown.

10

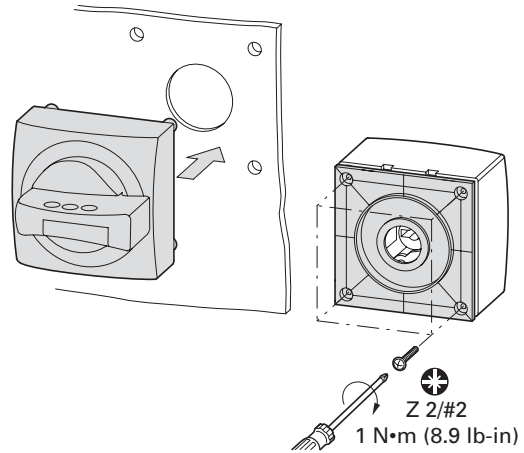

Step 10: Place switch handle on the enclosure door front so that the protruding screw guides are seated in the four mounting holes. From the rear, place the backer plate in position and secure with four supplied Phillips head screws. Torque to 1 N•m (8.9 lb-in) as shown.

11

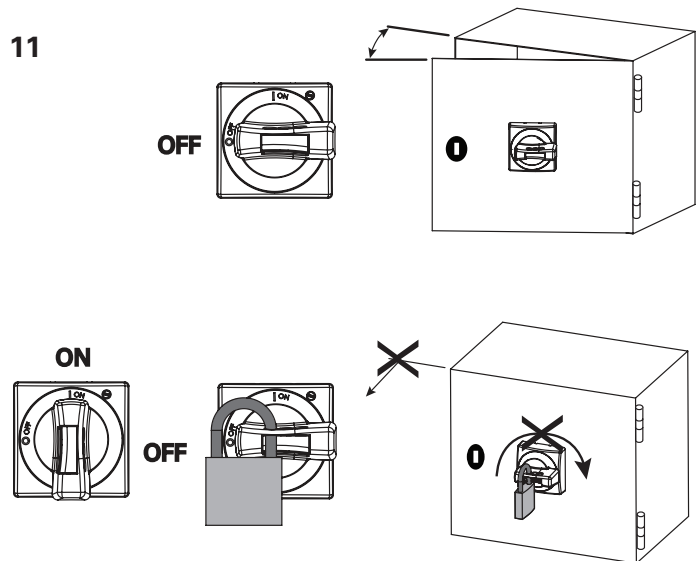

Step 11: Close and latch door. Check switch for proper operation in all modes. If not operating correctly, revisit these installation steps for remedial action.

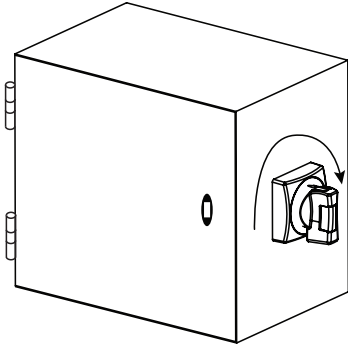

Right side clockwise handle operation and installation

The following applies to all clockwise operating selector and pistol switch handles. Illustrations are of the selector handle, but apply equally to pistol handle versions.

Procedures for clockwise handle catalog numbers:

- CCP2-H4X-B1 (selector)
- CCP2-H4X-R1 (selector)
- CCP2-H4X-B2 (pistol)
- CCP2-H4X-R2 (pistol)

For installation with switch catalog numbers:

- CCP2S-(pole)-30CC
- CCP2S-(pole)-30M
- CCP2S-(pole)-30CF
- CCP2S-(pole)-60CF
- CCP2S-(pole)-100CF
- CCD2S-(pole)-30
- CCD2S-(pole)-60
- CCD2S-(pole)-100

And either shaft catalog numbers:

- CCP2-SH1-290
- CCP2-SH1-490

Switch operating modes

NOTE: Side installation (handle mounted on the enclosure's side and not the door) does NOT provide for an interlock means to prevent opening the door while the switch is in either the ON or OFF position. If preventing access to the enclosure's interior is desired or required by the application, use a locking door latch or install a suitable hasp to accept a lock.

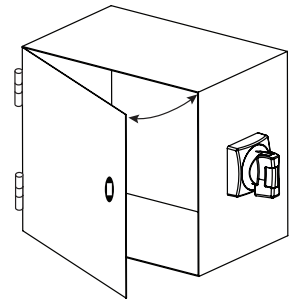
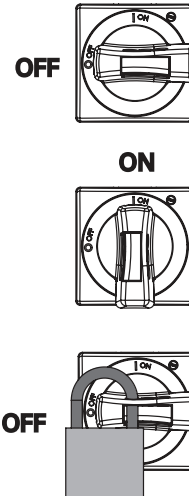

Handle lock ON operation

Note: NOT to be utilized when switch is applied as a means for emergency stop.

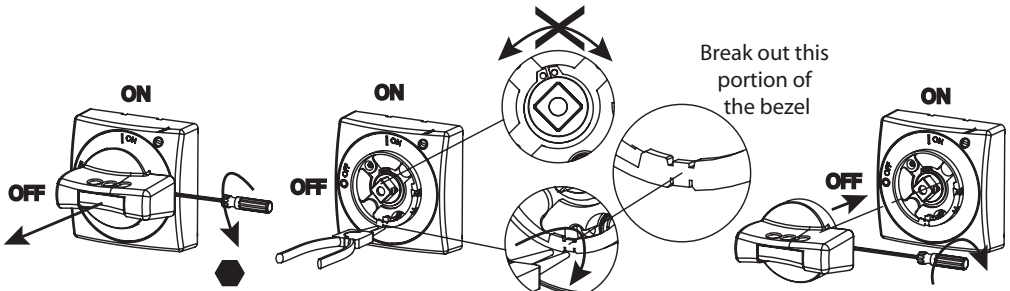

2 mm Allen wrench (selector handles) 2.5 mm Allen wrench (pistol handles) 3 N•m (27 lb-in)

To enable the handle's lock ON feature:

- Use a 2 mm (selector handle) or 2.5 mm (pistol handle) Allen wrench to loosen the setscrew and remove the handle from the handle base as shown.
- Using needle nose pliers, break off the retaining stop on the switch handle bezel as shown.
- Place handle back onto the handle base and tighten the setscrew.

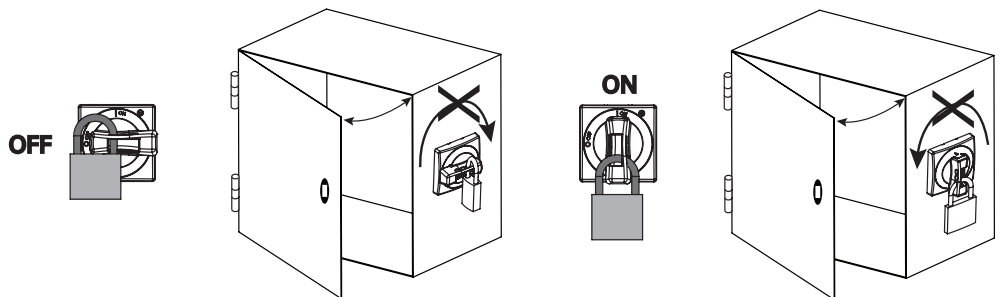

Clockwise handle installation for right side rotary operated switches

Applies to selector and pistol handles

1

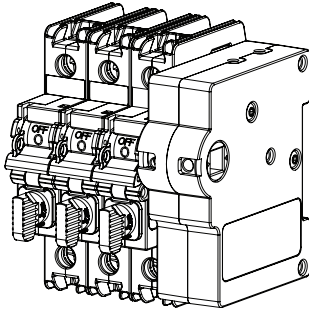

Right side rotary operated switch

Step 1: With switch mounted on a 35 mm DIN-Rail and in the OFF position, fully insert switch shaft and lightly tighten the setscrew using a 3 mm Allen wrench. Note the shaft is keyed so that it can only be inserted one way.

2

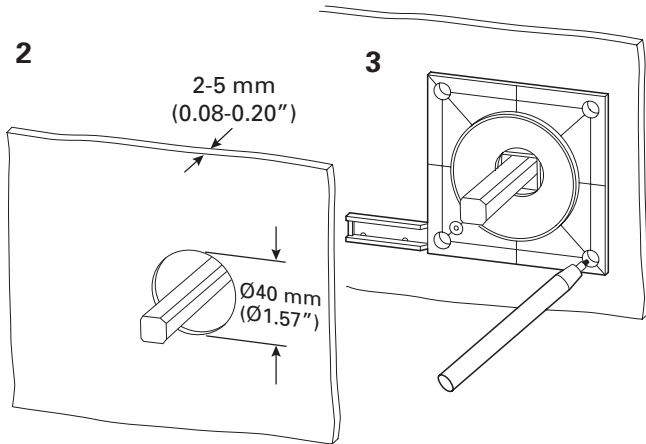

Step 2: Locate shaft's center on the enclosure's right side (shaft is perpendicular to the plane of the side). Then drill/punch a 40 mm (1.57") hole as shown and remove any burrs that may result from the drilling/punching process. Failure to remove burrs may impair the handle's lock OFF/lock ON function.

Note: Be careful to not distort the panel's surface. Doing so may compromise the handle's NEMA 4X seal or impair the handle's lock OFF/lock ON function.

Step 3: With switch shaft extending through the enclosure, place the handle backer plate onto the shaft as shown and fully seat backer plate into the hole. Align backer plate horizontally and vertically with the side and mark the centers for the four mounting holes as shown.

4

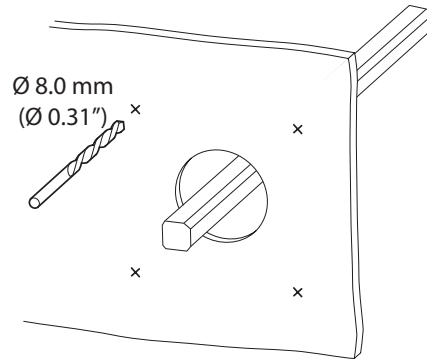

Step 4: Center punch and drill the four backer plate mounting holes using a 8.0 mm (0.31") bit as shown.

Removable depth gauge Removable shaft centering jig

5

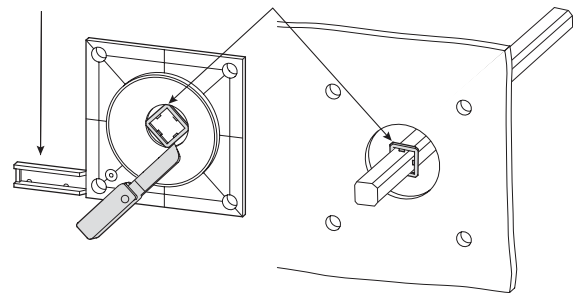

Step 5: Use a utility knife to cut and free the shaft centering jig from the backer plate and place it on the shaft as shown.

6

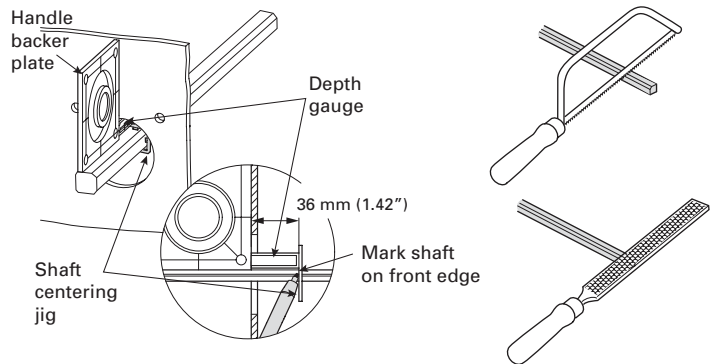

Step 6: Place the handle backer plate against the enclosure's side as shown and push the centering jig (now cut free and on the shaft) back until the edge of the handle backer plate is flush with the side.

Use a pencil or felt tip pen to mark the shaft on the front edge of the centering jig as shown. This is where the shaft is to be cut.

Loosen shaft setscrew on the switch, remove the shaft and cut to length where marked. File off any burrs on the cut end as shown.

Note: To ensure proper fit, make a square cut on the shaft.

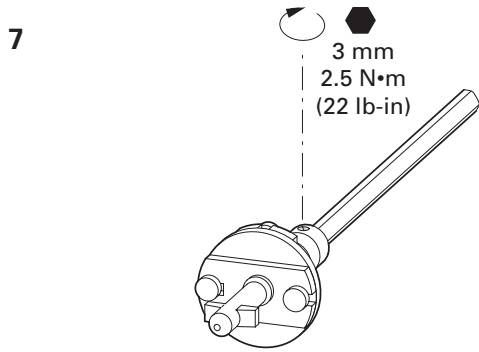

Step 7: Fully insert the shaft back into the switch making sure its indexing corner (largest flat on the shaft) is in the upper left corner of the switch shaft hole. Torque setscrew to 2.5 N•m (22 lb-in) using 3 mm Allen wrench. Place shaft coupler on the shaft as shown and torque setscrew to 2.5 N•m (22 lb-in) using 3 mm Allen wrench. Note the shaft is indexed so the shaft coupler can only be inserted one way.

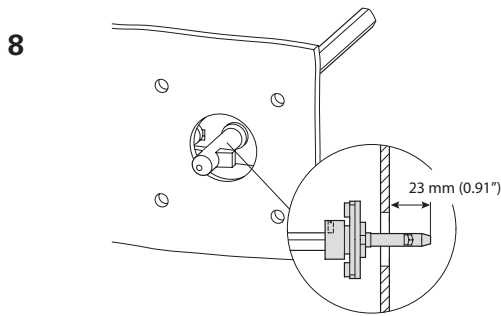

Step 8: Check the distance the shaft coupler extends beyond the enclosure's side as shown. If extension is too great, recut shaft accordingly and reinstall. If too short, install another shaft per previous instructions.

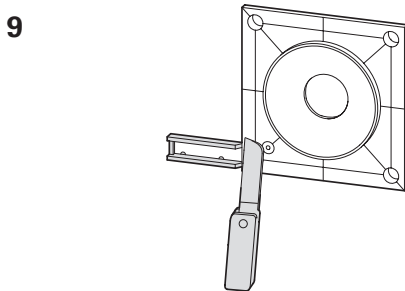

Step 9: Prepare the handle backer plate for mounting by removing the depth gauge as shown.

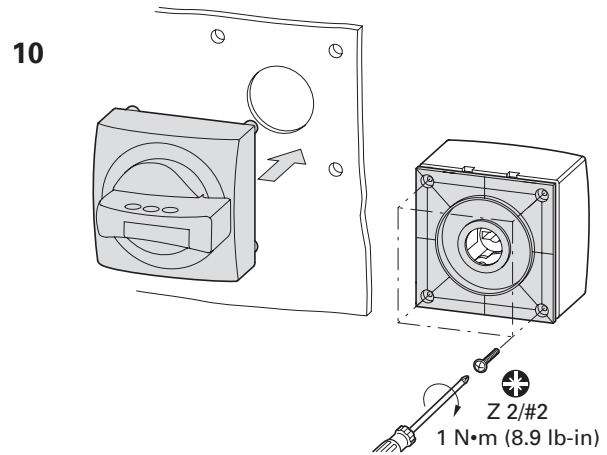

Step 10: Place switch handle on the enclosure's side so that the protruding screw guides are seated in the four mounting holes. From the inside, place the backer plate in position and secure with four supplied Phillips head screws. Torque to 1 N•m (8.9 lb-in) as shown.

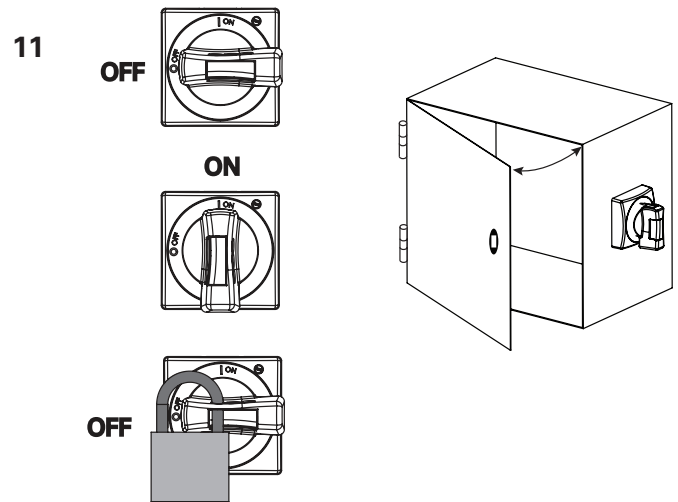

Step 11: Check switch for proper operation in all modes. If not operating correctly, revisit these installation steps for remedial action.

NOTE: Side installation (handle mounted on the enclosure's side and not the door) does NOT provide for an interlock means to prevent opening the door while the switch is in either the ON or OFF position. If preventing access to the enclosure's interior is desired or required by the application, use a locking door latch or install a suitable hasp to accept a lock.

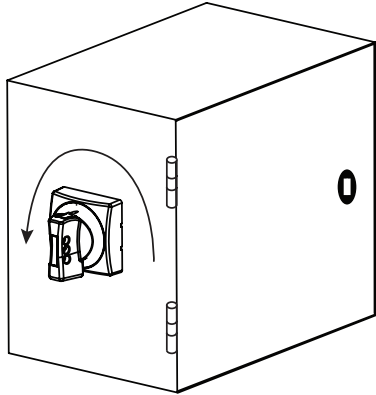

Left side counterclockwise handle operation and installation

The following applies to all counterclockwise operating selector and pistol switch handles. Illustrations are of the selector handle, but apply equally to pistol handle versions.

Procedures for clockwise handle catalog numbers:

- CCP2-H4X-B1L (selector)
- CCP2-H4X-R1L (selector)
- CCP2-H4X-B2L (pistol)
- CCP2-H4X-R2L (pistol)

For installation with switch catalog numbers:

- CCP2SL-(pole)-30CC
- CCP2SL-(pole)-30M
- CCP2SL-(pole)-30CF
- CCP2SL-(pole)-60CF
- CCP2SL-(pole)-100CF
- CCD2SL-(pole)-30
- CCD2SL-(pole)-60
- CCD2SL-(pole)-100

And either shaft catalog numbers:

- CCP2-SH1-290
- CCP2-SH1-490

Switch operating modes

NOTE: Side installation (handle mounted on the enclosure's side and not the door) does NOT provide for an interlock means to prevent opening the door while the switch is in either the ON or OFF position. If preventing access to the enclosure's interior is desired or required by the application, use a locking door latch or install a suitable hasp to accept a lock.

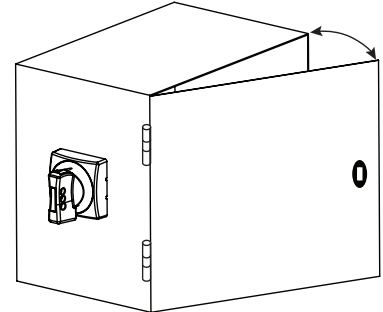
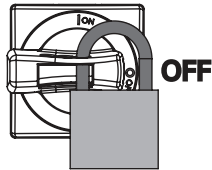
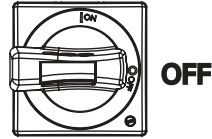

Handle lock ON and OFF operation

Note: Lock "ON" NOT to be utilized when switch is applied as a means for emergency stop.

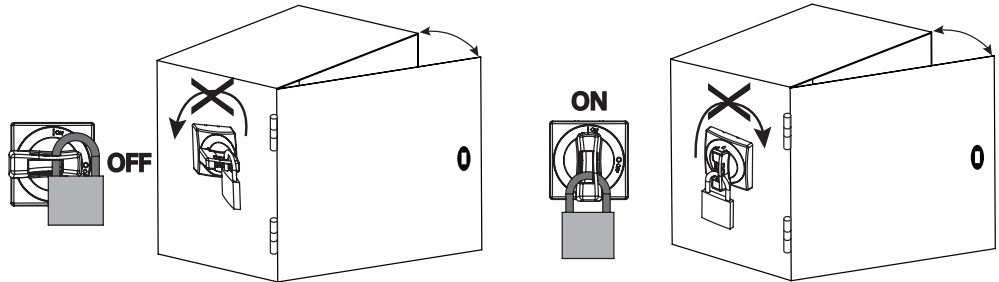

The counterclockwise rotating handles are factory configured for both lock ON and lock OFF.

To lock the switch, simply rotate the handle to the desired switch state (ON or OFF), depress the switch locking mechanism and insert up to three 1/4" locks.

Counterclockwise handle installation for left side rotary operated switches

Applies to selector and pistol handles

1

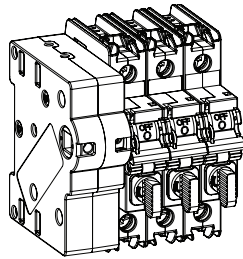

Left side rotary operated switch

Step 1: With switch mounted on a 35 mm DIN-Rail and in the OFF position, fully insert switch shaft and lightly tighten the setscrew using a 3 mm Allen wrench. Note the shaft is keyed so that it can only be inserted one way.

2

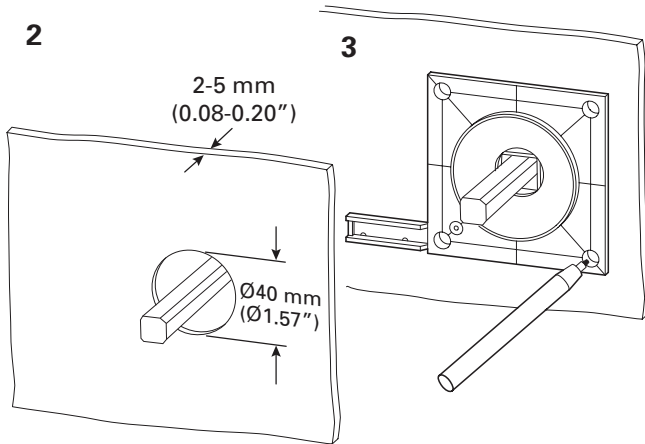

Step 2: Locate shaft's center on the enclosure's left side (shaft is perpendicular to the plane of the side). Then drill/punch a 40 mm (1.57") hole as shown and remove any burrs that may result from the drilling/punching process. Failure to remove burrs may impair the handle's lock OFF/lock ON function.

Note: Be careful to not distort the panel's surface. Doing so may compromise the handle's NEMA 4X seal or impair the handle's lock OFF/lock ON function.

Step 3: With switch shaft extending through the enclosure, place the handle backer plate onto the shaft as shown and fully seat backer plate into the hole. Align backer plate horizontally and vertically with the side and mark the centers for the four mounting holes as shown.

4

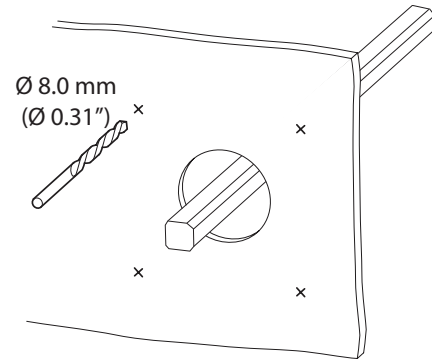

Step 4: Center punch and drill the four backer plate mounting holes using a 8.0 mm (0.31") bit as shown.

5

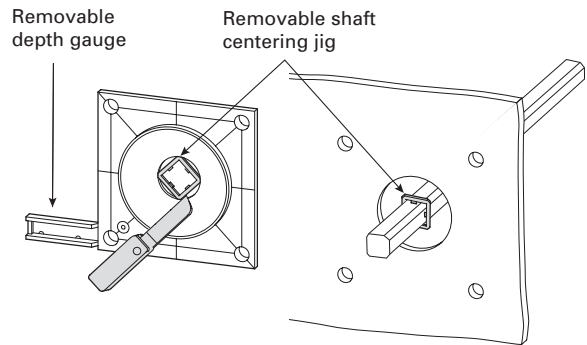

Step 5: Use a utility knife to cut and free the shaft centering jig from the backer plate and place it on the shaft as shown.

6

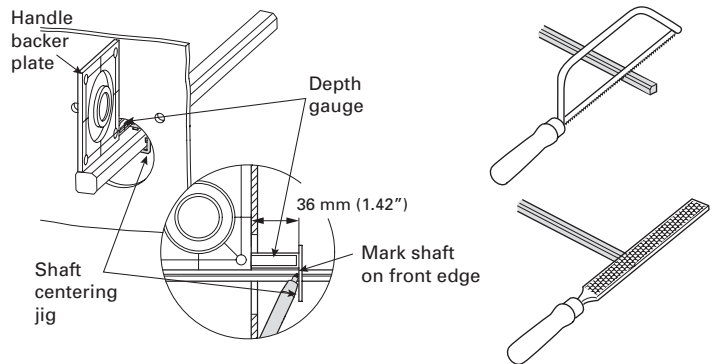

Step 6: Place the handle backer plate against the enclosure's side as shown and push the centering jig (now cut free and on the shaft) back until the edge of the handle backer plate is flush with the side.

Use a pencil or felt tip pen to mark the shaft on the front edge of the centering jig as shown. This is where the shaft is to be cut.

Loosen shaft setscrew on the switch, remove the shaft and cut to length where marked. File off any burrs on the cut end as shown.

Note: To ensure proper fit, make a square cut on the shaft.

7

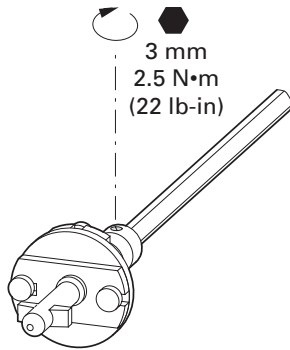

Step 7: Fully insert the shaft back into the switch making sure its indexing corner (largest flat on the shaft) is in the upper left corner of the switch shaft hole. Torque setscrew to 2.5 N•m (22 lb-in) using 3 mm Allen wrench. Place shaft coupler on the shaft as shown and torque setscrew to 2.5 N•m (22 lb-in) using 3 mm Allen wrench. Note the shaft is indexed so the shaft coupler can only be inserted one way.

8

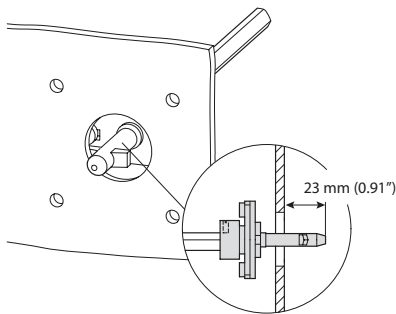

Step 8: Check the distance the shaft coupler extends beyond the enclosure's side as shown. If extension is too great, recut shaft accordingly and reinstall. If too short, install another shaft per previous instructions.

9

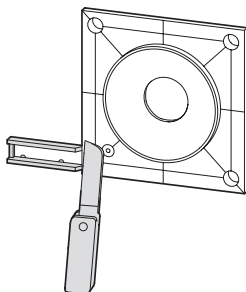

Step 9: Prepare the handle backer plate for mounting by removing the depth gauge as shown.

10

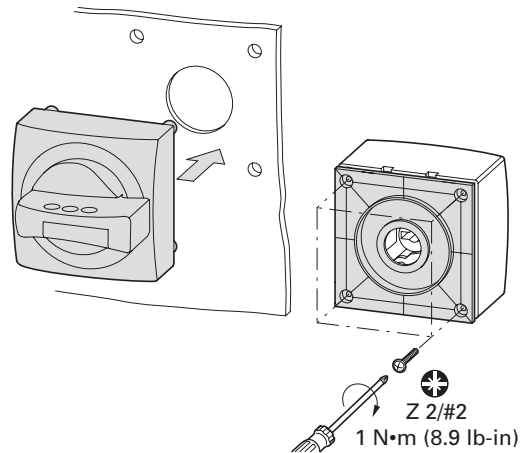

Step 10: Place switch handle on the enclosure's side so that the protruding screw guides are seated in the four mounting holes. From the inside, place the backer plate in position and secure with four supplied Phillips head screws. Torque to 1 N•m (8.9 lb-in) as shown.

11

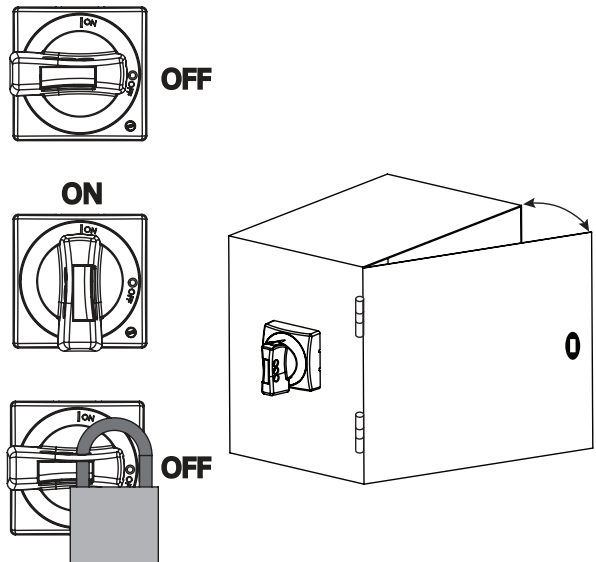

Step 11: Check switch for proper operation in all modes. If not operating correctly, revisit these installation steps for remedial action.

NOTE: Side installation (handle mounted on the enclosure's side and not the door) does NOT provide for an interlock means to prevent opening the door while the switch is in either the ON or OFF position. If preventing access to the enclosure's interior is desired or required by the application, use a locking door latch or install a suitable hasp to accept a lock.

Eaton
1000 Eaton Boulevard
Cleveland, OH 44122
Eaton.com

Bussmann Division
114 Old State Road
Ellisville, MO 63021
United States
Eaton.com/bussmannseries

© 2019 Eaton
All Rights Reserved
Printed in USA
Publication No. 3A3695
February 2019

Eaton and Bussmann are valuable trademarks of Eaton in the U.S. and other countries. You are not permitted to use the Eaton trademarks without prior written consent of Eaton.

ANSI is a registered trademark of the American National Standards Association
IEEE is a registered trademark of the Institute of Electrical and Electronics Engineers
NEMA is a registered trademark of the National Electrical Mfgs. Association
NFPA is a registered trademark of the National Fire Protection Association
UL is a registered trademark of the Underwriters Laboratories, Inc.