

30A CUBE Fuse Installed

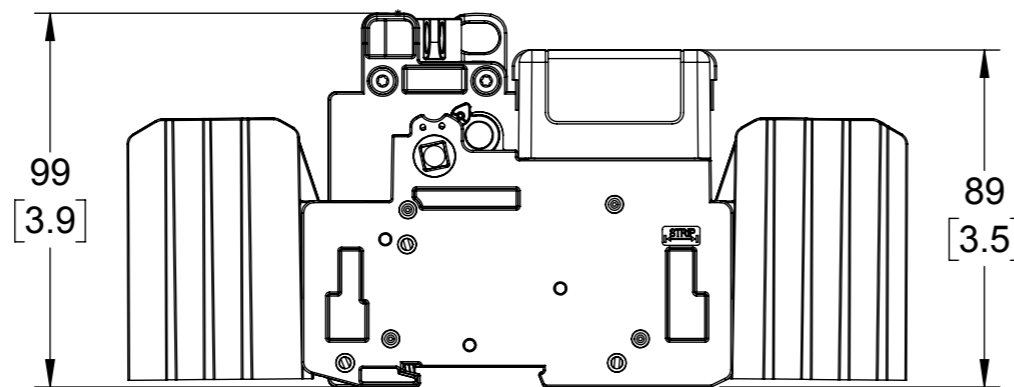

60A CUBE Fuse Installed

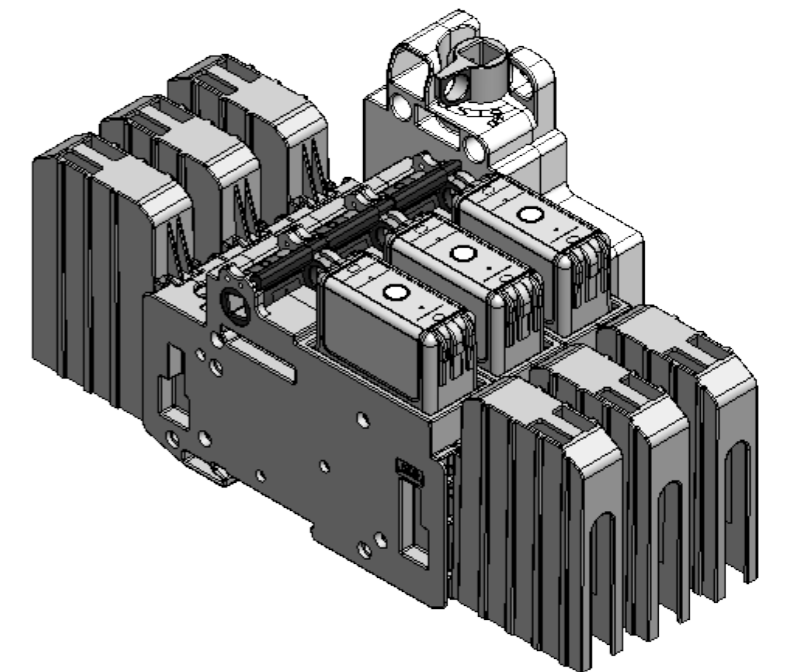

EATON CORPORATION - CONFIDENTIAL
AND PROPRIETARY
NOTICE TO PERSONS RECEIVING THIS DOCUMENT AND/OR TECHNICAL
INFORMATION

THIS DOCUMENT, INCLUDING THE DRAWING AND INFORMATION CONTAINED THEREON,
IS CONFIDENTIAL AND IS THE EXCLUSIVE PROPERTY OF EATON CORPORATION AND
IS MERELY ON LOAN AND SUBJECT TO RECALL BY EATON AT ANY TIME. BY TAKING
POSSESSION OF THE DOCUMENT, THE RECIPIENT ACKNOWLEDGES AND AGREES THAT
THIS DOCUMENT CANNOT BE USED IN ANY MANNER ADVERSE TO THE INTERESTS OF
EATON AND THAT NO PORTION OF THIS DOCUMENT MAY BE COPIED OR OTHERWISE
REPRODUCED WITHOUT THE PRIOR WRITTEN CONSENT OF EATON. IN THE CASE OF
CONFLICTING CONTRACTUAL PROVISIONS, THIS NOTICE SHALL GOVERN THE
STATUS OF THIS DOCUMENT.

© 2012 Eaton Corporation. All Rights Reserved.

THIS DRAWING IS AN UNCONTROLLED COPY IF PRINTED OR
SENT ELECTRONICALLY. DO NOT SCALE DRAWING
GENERAL DRAWING PRACTICES IN
ACCORDANCE WITH ASME - Y14.100-2004
DIMENSIONS AND TOLERANCES IN
ACCORDANCE WITH ASME - Y14.5M-1994

UNLESS OTHERWISE SPECIFIED
DIMENSIONS ARE IN INCHES
UNLESS OTHERWISE SPECIFIED TOLERANCES TO BE
FRACTIONAL $\pm 1/64"$
INCHES $\pm .005"$
ANGULAR $\pm 1^\circ$

CUSTOMER PRINT
THIRD ANGLE PROJECTION

EATON BUSSMANN
SERIES

TITLE		REV	
SIZE	DWG NO.	REV	
A3	CCP2R-3-30CF	--	
SCALE:	1:2	SHEET	1 OF 1