

# Neutral current sensors Magnum PXR and Power Defense SB ACB trip units

Instructions apply to:

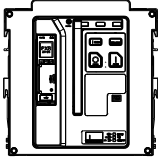

---

## **⚠ WARNING**

---

- (1) **ONLY QUALIFIED ELECTRICAL PERSONNEL SHOULD BE PERMITTED TO WORK ON THE EQUIPMENT.**
  - (2) **ALWAYS DE-ENERGIZE PRIMARY AND SECONDARY CIRCUITS IF A CIRCUIT BREAKER CANNOT BE REMOVED TO A SAFE WORK LOCATION.**
  - (3) **DRAWOUT CIRCUIT BREAKERS SHOULD BE LEVERED (RACKED) OUT TO THE DISCONNECT POSITION.**
  - (4) **ALL CIRCUIT BREAKERS SHOULD BE SWITCHED TO THE OFF POSITION AND MECHANISM SPRINGS DISCHARGED.**
- FAILURE TO FOLLOW THESE STEPS FOR ALL PROCEDURES DESCRIBED IN THIS INSTRUCTION LEAFLET COULD RESULT IN DEATH, BODILY INJURY, OR PROPERTY DAMAGE.**

---

## **⚠ WARNING**

---

**THE INSTRUCTIONS CONTAINED IN THIS IL AND ON PRODUCT LABELS HAVE TO BE FOLLOWED. OBSERVE THE FIVE SAFETY RULES:**

- DISCONNECTING**
- ENSURE THAT DEVICES CANNOT BE ACCIDENTALLY RESTARTED**
- VERIFY ISOLATION FROM THE SUPPLY**
- EARTHING AND SHORT-CIRCUITING**
- COVERING OR PROVIDING BARRIERS TO ADJACENT LIVE PARTS.**

**DISCONNECT THE EQUIPMENT FROM THE SUPPLY. USE ONLY AUTHORIZED SPARE PARTS IN THE REPAIR OF THE EQUIPMENT. THE SPECIFIED MAINTENANCE INTERVALS, AS WELL AS THE INSTRUCTIONS FOR REPAIR AND EXCHANGE, MUST BE STRICTLY ADHERED TO PREVENT INJURY TO PERSONNEL AND DAMAGE TO THE SWITCHBOARD.**

# **EAT•N**

*Powering Business Worldwide*

### Section 1: Neutral current sensor installation

Ground fault trip units detect ground fault current through residual sensing. If the system neutral is grounded and residual ground fault is desired, but no phase to neutral loads are used, a neutral current sensor is not necessary.

If the system neutral is grounded and phase to neutral loads are used, then the neutral current sensor must be used to account for this load in the residual ground fault sensing.

Magnum PXR and Power Defense SB (PD-SB) trip units come with the option of connecting either a current transformer (CT) or a Rogowski coil as the neutral sensor. Whichever current sensor is selected, it is connected to the same two secondary terminals. Refer to **Figure 1** for Rogowski connections and **Figure 3** for CT connections. Note that the sensor can be mounted in the opposite orientation if the secondary wiring is also reversed. Double-wide breakers can use a single neutral sensor of either type or two CT type sensors mounted and wired in parallel (**Figure 3**). Only the current sensors described in this document should be used with Magnum PXR and PD-SB trip units. Refer to **Figures 4 & 5** for dimensional and labeling details.

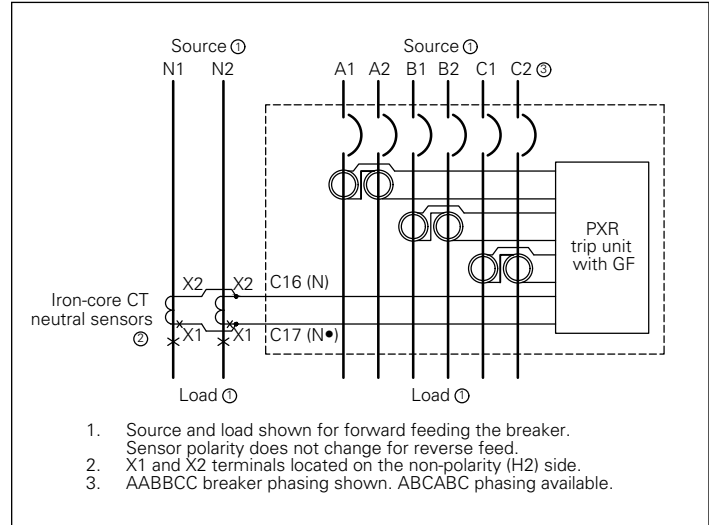

**Figure 3. Double frame iron-core CT neutral sensor option.**

Refer to **Figure 4** for instructions on how to use the PXR 20 or PXR 25 trip unit display to select the type of sensor that you are using. If no sensor is used, the CT selection should be made (this is the factory default setting). If Rogowski is selected and no coil is connected, false current readings and possibly trips will occur.

From PXR 20/25 Main Menu:  
 Edit Settings → [PW] → Unit Settings → Neutral Sensor → [Rogowski/CT]

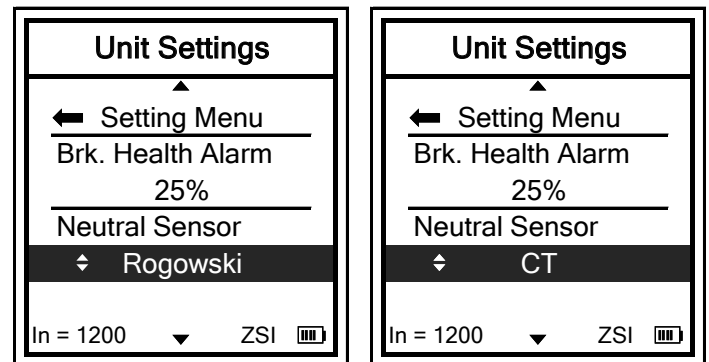

**Figure 4. Current sensor selection PXR 20/25 trip unit menus.**

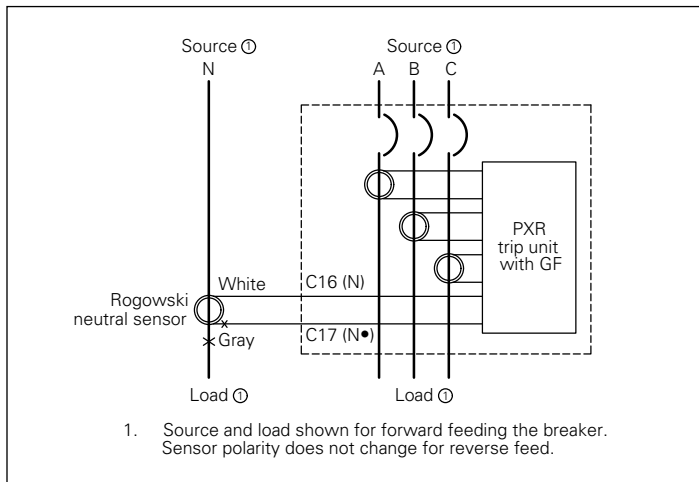

**Figure 1. Rogowski coil (bus-bar) neutral current sensor application.**

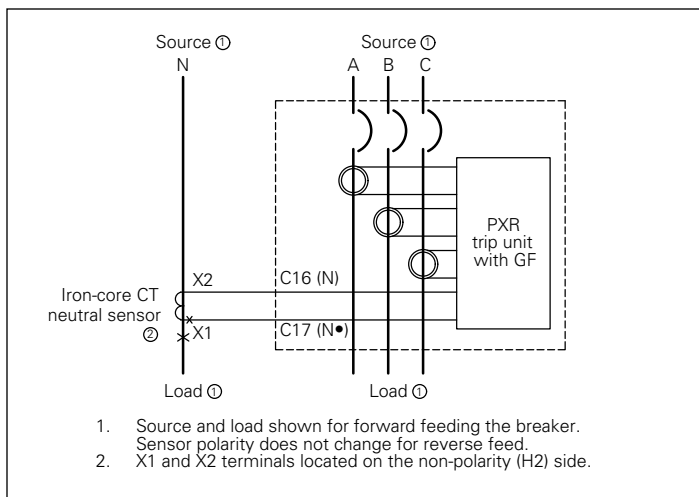

**Figure 2. Iron-core CT (window) neutral current sensor application.**

**Table 1. Catalog number and use details**

Frame	Application	Catalog#	Connection diagram	Dimensions
All	Rogowski (bus bar)	NRMPN	Figure 1	Figure 5
All	Iron-core CT (window)	MSCNCT	Figures 2 & 3	Figure 6

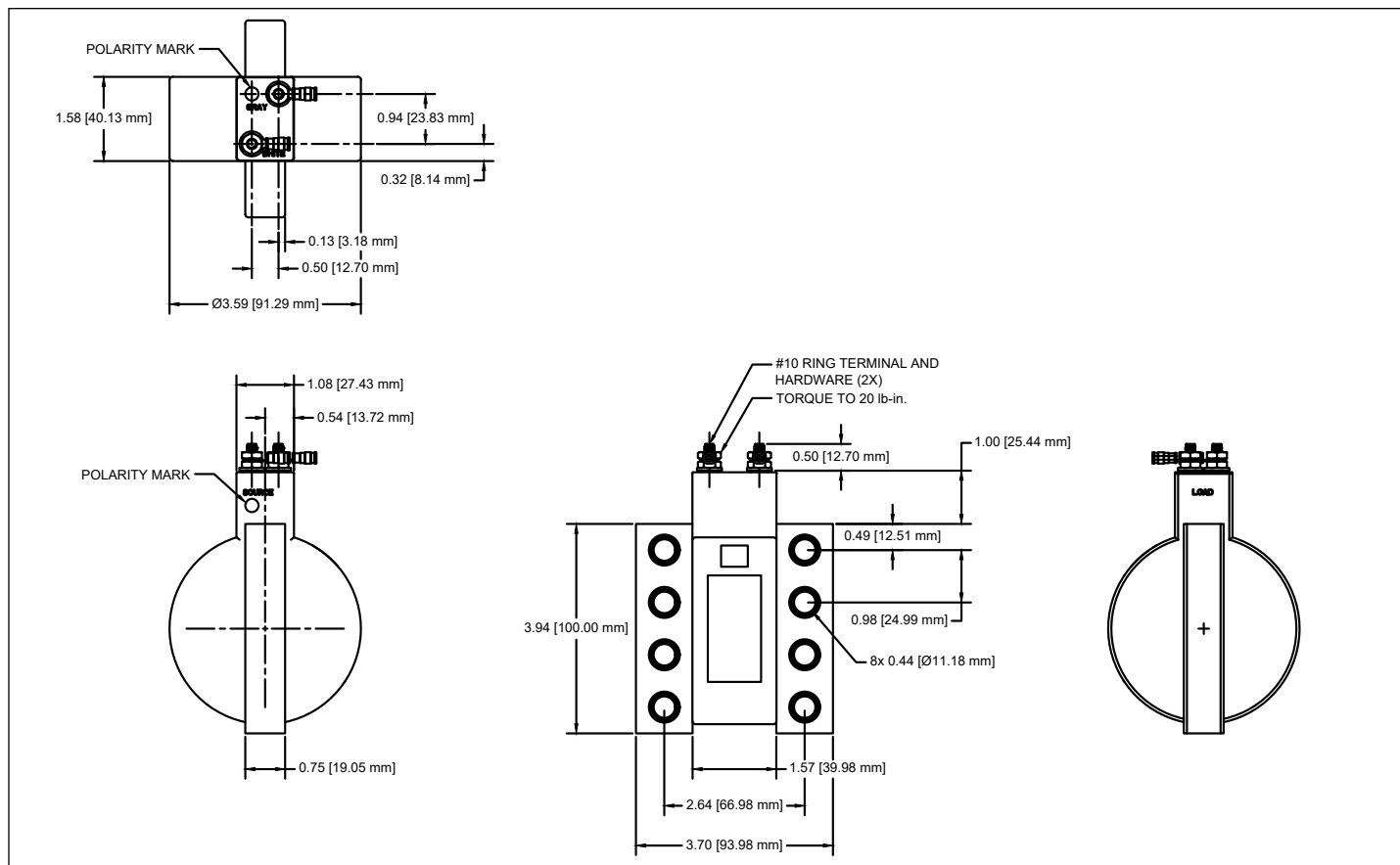

Figure 5. Rogowski (busbar) type dimensions.

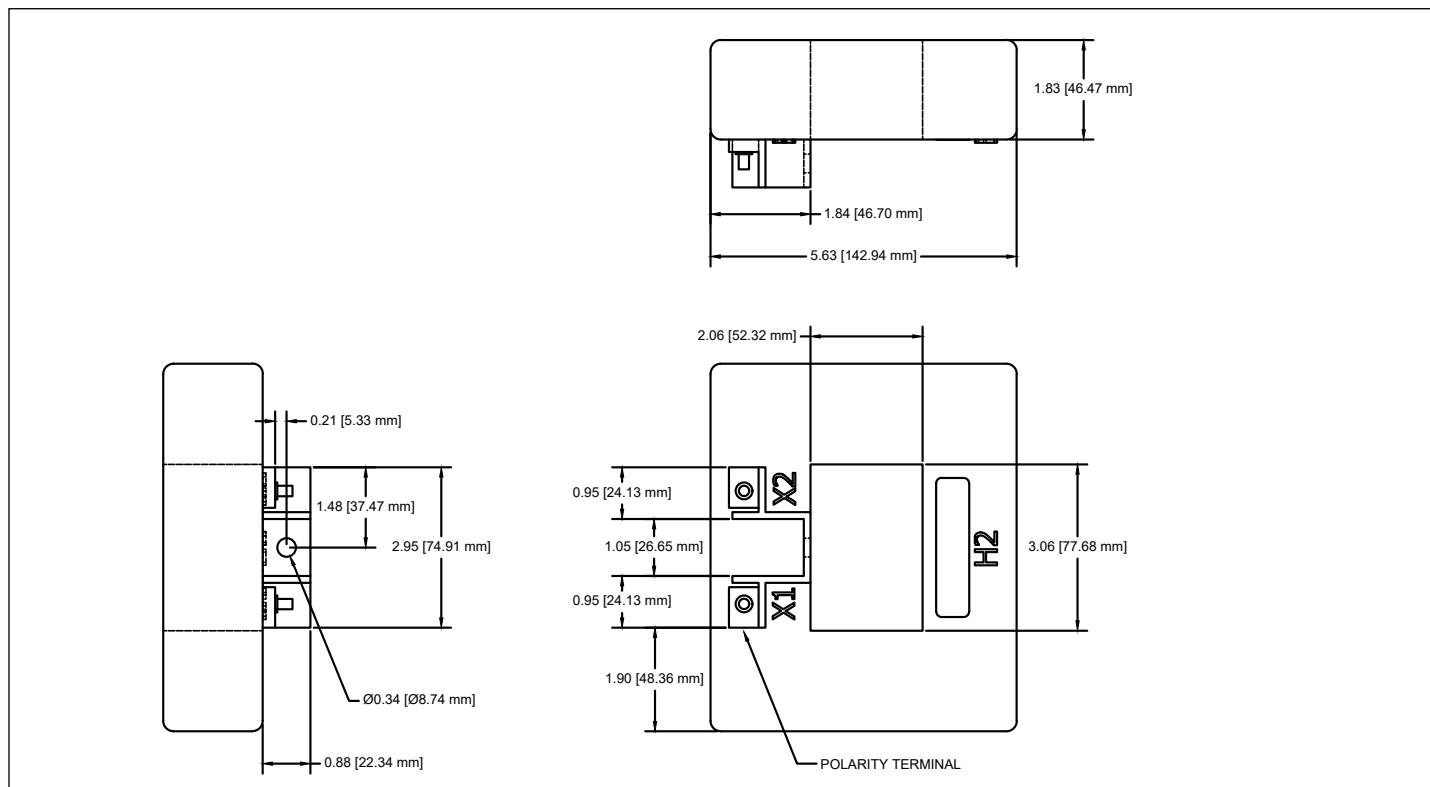

Figure 6. Iron-core CT (window) type dimensions – non-polarity (H2) side shown.

## Section 2: Performance testing for ground fault circuit breakers

Please consult Instruction Leaflet number IL012125EN for general instructions to aid you in ground fault testing of circuit breakers with PXR electronic trip units. Application Paper number AP013002EN includes field testing instructions for ground fault systems utilizing Magnum PXR and PD-SB breakers. This includes main-tie-main system applications.

### General test instructions

The interconnect system shall be evaluated in accordance with the equipment assembler's detailed instruction by qualified personnel.

The polarity of the neutral sensor connection (if used) must agree with equipment assembler's detailed instructions to avoid improper operations following apparently correct simulated test operations. Where a question exists, consult the specifying engineer and/or equipment assembler.

The grounding points of the system shall be verified to determine that ground paths do not exist that would bypass the sensors. High-voltage testers and resistance bridges may be used.

---

### IMPORTANT

---

**THE POLARITY OF THE SENSOR CONNECTIONS IS CRITICAL. ALWAYS OBSERVE THE POLARITY MARKINGS ON THE INSTALLATION DRAWINGS. THE POLARITY MARKINGS ARE IDENTIFIED AS WHITE DOTS ON THE TRANSFORMERS. TO INSURE CORRECT GROUND FAULT EQUIPMENT PERFORMANCE, CONDUCT FIELD TESTS TO COMPLY WITH NATIONAL ELECTRIC CODE REQUIREMENTS UNDER ARTICLE 230-95-C. SEE PERFORMANCE TESTING INSTRUCTIONS ON IL012125EN.**

---

**Note:** Since the ground fault circuit breakers derive their operating power from the phase current and not from the neutral current, passing current through the neutral sensor only will not properly test the ground fault feature.

**Notes:**

## Disclaimer of warranties and limitation of liability

The information, recommendations, descriptions and safety notations in this document are based on Eaton Corporation's ("Eaton") experience and judgment and may not cover all contingencies. If further information is required, an Eaton sales office should be consulted. Sale of the product shown in this literature is subject to the terms and conditions outlined in appropriate Eaton selling policies or other contractual agreement between Eaton and the purchaser.

THERE ARE NO UNDERSTANDINGS, AGREEMENTS, WARRANTIES, EXPRESSED OR IMPLIED, INCLUDING WARRANTIES OF FITNESS FOR A PARTICULAR PURPOSE OR MERCHANTABILITY, OTHER THAN THOSE SPECIFICALLY SET OUT IN ANY EXISTING CONTRACT BETWEEN THE PARTIES. ANY SUCH CONTRACT STATES THE ENTIRE OBLIGATION OF EATON. THE CONTENTS OF THIS DOCUMENT SHALL NOT BECOME PART OF OR MODIFY ANY CONTRACT BETWEEN THE PARTIES.

In no event will Eaton be responsible to the purchaser or user in contract, in tort (including negligence), strict liability or otherwise for any special, indirect, incidental or consequential damage or loss whatsoever, including but not limited to damage or loss of use of equipment, plant or power system, cost of capital, loss of power, additional expenses in the use of existing power facilities, or claims against the purchaser or user by its customers resulting from the use of the information, recommendations and descriptions contained herein. The information contained in this manual is subject to change without notice.

**Eaton**  
1000 Eaton Boulevard  
Cleveland, OH 44122  
United States  
877-ETN-CARE (877-386-2273)  
Eaton.com

© 2024 Eaton  
All Rights Reserved  
Printed in USA  
Publication No. IL0131154EN TBG001631  
Part number: IL0131154ENH02  
January 2024