

Suretrac™ Differential

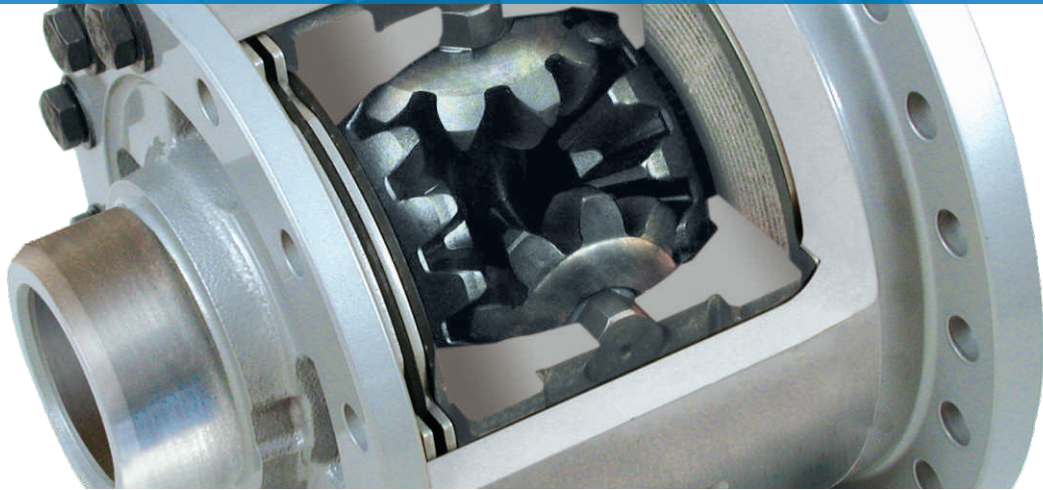

Availability

- Military and commercial axles
- Used in Caterpillar, General Dynamics, John Deere, Komatsu and Volvo vehicles

Benefits

- Extremely rugged and durable
- Reduces shock loads that can damage the drive train
- Proven track record of heavy duty vehicle manufacturers
- Smooth automatic operation
- Significantly reduces tire wear
- Limits wheel spin out
- Increases productivity

Principle of Operation

- Combines conventional type differential components with large piston (actuator housing) to compress additional friction packs

Technical Specifications

- Automatic torque bias takes place within a fraction of a second
- Front, rear or transfer case applications
- Ability to fine tune torque bias ratios, usually between 2.5:1 and 4.0:1

Applications

- US Army - Stryker
- Wheel Loaders
- Armored Trucks
- Articulated Trucks
- Agricultural Tractors
- On/Off Highway Trucks
- Single Engine Scrapers
- Military APC



Suretrac™ Differential

The Eaton Suretrac GA is a heavy-duty limited slip differential for construction, military, farming and other specialty vehicles.

The Suretrac GA performs like an open differential under “normal” conditions, and automatically transfers torque to the wheel with better traction when conditions warrant. The Suretrac GA limited slip differential responds instantly to torque feedback, anytime, at any speed. Suretrac GA reduces one wheel spin-outs from disabling the vehicle and also limits shock loads on drive train components to extend their life.

Suretrac transfers torque flow by combining

conventional type differential components with large piston (actuator housing) to compress additional friction packs. The special coated friction plates react to movement between the side gears and the differential case. The wheel with the least traction is locked and power is transferred to the wheel that has the best traction.

The Suretrac GA series consists of standard type differential gears and spider shafts, a series of friction and reaction plates, and actuators. The plates are compressed by the actuators as they separate due to the ramp angle mesh with the spider shafts.

Traction That Works!

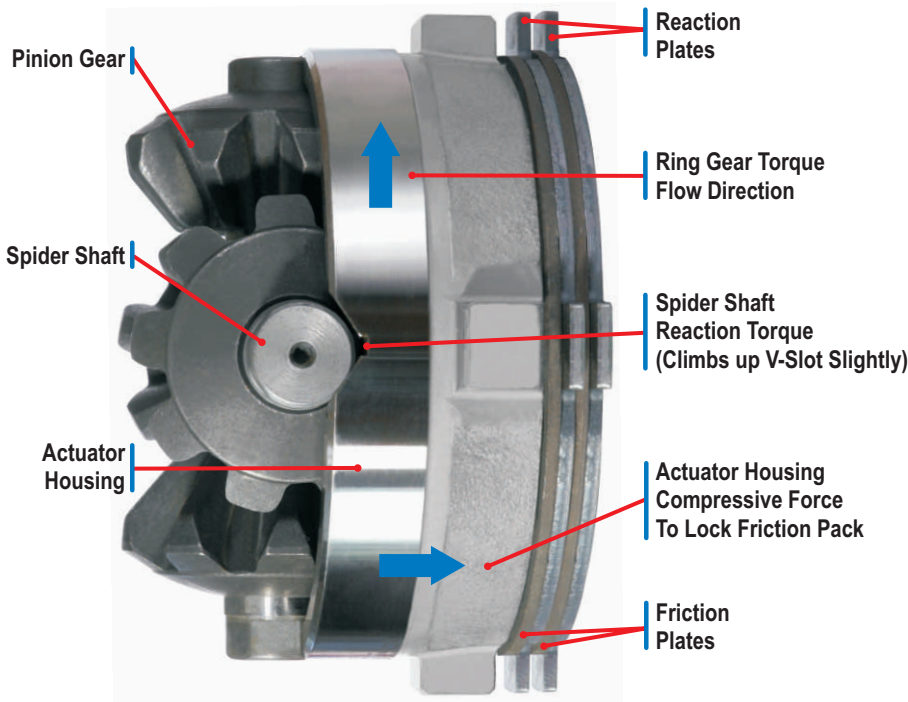

NORTH AMERICA
Southfield, MI, United States
Tel: +1-248-226-6200

SOUTH AMERICA
Sao Jose dos Campos, Brazil
Tel: +55-12-3934-0783

INDIA
Pune, Maharashtra, India
Tel: +91-20-30611111

CHINA
Shanghai, China
Tel: +86-21-58917006-262

JAPAN
Tokyo, Japan
Tel: +81-3-3746-3141

KOREA
Pyungtek-si, Korea
Tel: +82-31-610-7455

NORTHERN EUROPE
Rastatt, Germany
Tel: +49-7222-159-980

SOUTHERN EUROPE
Turin, Italy
Tel: +39-011-2208111

www.eaton.com