

Medium-voltage power distribution and control systems > Switchgear >

# Metal-enclosed switchgear— MVS medium-voltage 5–15 kV load interrupter switch

## Contents

<b>General Description</b> .....	<b>8.1-2</b>
MVS Load Interrupter Switchgear .....	8.1-2
Mini-MVS (26-Inch Wide) .....	8.1-6
MVS and Mini-MVS Switchgear Assembly Ratings ..	8.1-7
<b>Devices</b> .....	<b>8.1-8</b>
Switch Technical Data .....	8.1-8
Motor Operated MVS .....	8.1-10
Metering .....	8.1-11
System Options .....	8.1-12
MVS Switchgear with Automatic Transfer Control ...	8.1-14
<b>Layouts and Dimensions</b> .....	<b>8.1-16</b>
MVS Layouts .....	8.1-16
Mini-MVS Layouts .....	8.1-22
<b>Application Data</b> .....	<b>8.1-23</b>
Weights .....	8.1-23



*Powering Business Worldwide*

## MVS Load Interrupter Switchgear

Eaton's MVS Load Interrupter Switchgear is an integrated assembly of switches, bus and fuses that is constructed for medium-voltage circuit protection. All major components are manufactured by Eaton, establishing one source of responsibility for the equipment's performance and ensuring high standards in quality, coordination, reliability and service.

A complete line of Eaton switches and fuses is available:

- 5 kV and 15 kV voltage classes
- 600 A and 1200 A continuous load interrupting ratings for 5 kV and 15 kV classes
- 350 A continuous and load interrupting ratings for 5 kV and 15 kV classes for capacitive circuits
- Non-fused or fused with current limiting or boric acid-type fuses
- Manual or motor operated
- Indoor or outdoor non-walk-in enclosures
- Single switches and transformer primary switches
- Duplex loadbreak switch arrangements for selection of alternate feeds
- Two-position, manual no-load selector switches for selection of alternate feeds
- Lineups with main bus
- Standard arrangements with automatic transfer control systems (two sources feeding one bus or two sources feeding two buses with tie switch)

Standard design configurations for:

- NEMA® pads for cable lugs
- Surge arresters
- Instrument transformers
- Control power transformers
- Power Xpert® and IQ electronic metering
- Other auxiliary equipment



*Outdoor Duplex with Customer Metering*

### Application Description

Eaton's Load Interrupter Type MVS metal-enclosed switchgear provides safe, reliable switching and fault protection for medium-voltage circuits rated from 2.4 kV to 15 kV. The MVS switch is ideal for applications where high duty cycle operation is not required.

MVS switchgear has the advantage of low initial cost inherent in switch designs while offering the characteristics most vital to safety and coordination.

The MVS switch's quick-make, quick-break mechanism provides full-load current interrupting capability while fuses provide accurate, permanently calibrated short circuit detecting and interrupting capabilities. Visibility of actual blade position improves safety by giving positive assurance of circuit de-energization.

### Standards and Certifications

Eaton's MVS load interrupter switchgear meets or exceeds the requirements of the following industry standards:

- IEEE® Standard C37.20.3
- ANSI C37.57
- NEMA SG5
- Canadian Standard CAN/CSA® C22.2 No. 31

Type MVS switches meet or exceed the requirements of the following industry standards:

- IEEE Standard C37.20.4
- ANSI C37.58
- ANSI C37.22
- NEMA SG6
- Canadian Standards CAN/CSA C22.2 No. 193 and CAN/CSA C22.2 No. 58

5 kV and 15 kV MVS switchgear assemblies are available as listed products with **Underwriters Laboratories and Canadian Standards Association** for most options.

**Load interrupter switches should not be used to interrupt load currents above their interrupting rating of 600 A or 1200 A, as they are not designed nor tested for interrupting fault currents on electrical systems. Optional fuses can be provided for phase overcurrent protection.**

**Switch Mechanism**

The quick-make, quick-break mechanism uses a heavy-duty coil spring that provides powerful opening and closing action. To close the switch, the handle is inserted into the spring charging cam, then rotated upward through an angle of 120 degrees. This action charges the operating spring, as the mechanism is forced past toggle. The stored energy of the spring is released and transferred to the main shaft that snaps the switch closed.

As a result of the over-toggle action, the blades are moved independently of the operator. It is impossible to operate the switch into an intermediate position.

To open the switch, the handle is inserted into the spring charging cam and rotated downward through 120 degrees resulting in charging of the operating spring, then releasing its stored energy in similar sequence.

**Quick-Break DE-ION Arc Interruption**

With the switch closed, both main and auxiliary (flicker) blades are closed, and all of the current flows through the main blades. The flicker blades are in the closed position in the arc chutes, but are past the arcing contacts and thus carry no current. As the main blades open, current is transferred momentarily to the flicker blades, which are held in the arc chutes by high pressure contact fingers. There is no arcing at the main blades.

When the main blades reach a pre-determined angle of opening, a stop post on the main blades prevents further angular movement between the main and flicker blades. This starts the flicker blades out of the high pressure contacts in the arc chutes and as contacts are broken, the flicker blades are snapped into position by their torsion springs.

The heat of the arc, meanwhile, releases a blast of de-ionizing gas from the gas-generating material of the arc chute. This combination of quick-break and DE-ION action quickly extinguishes the arc and the circuit is safely de-energized.

A non-fused switch has the ability to close and latch four times when rated 40 kA and one time when rated 61 kA and continue to carry rated current thus adding a large margin of integrity to the electrical system.

The 5/15 kV switch designs have also demonstrated the ability to surpass the number of ANSI C37.22 required loadbreak current operations by no less than 200%.

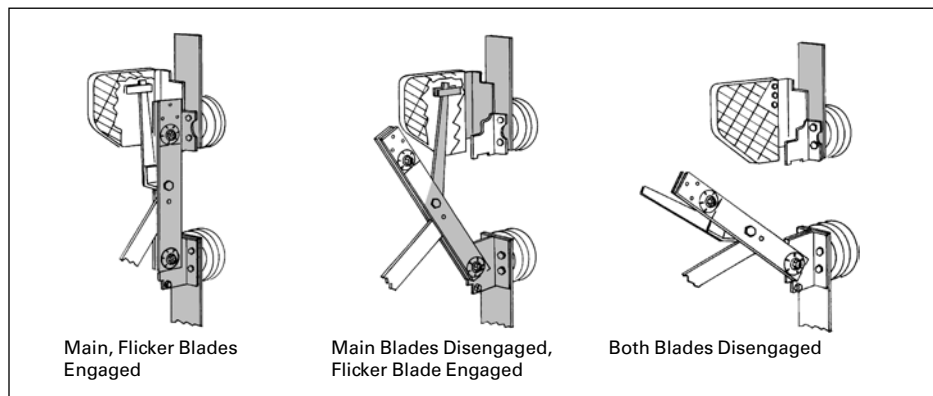
**Bus Insulation System**

All bus runs are supported using a high strength and high creep, finned support providing in excess of 12.00 inches (304.8 mm) for 5/15 kV of creep distance between phases and ground. The molded high track-resistant fins are constructed as standard of Aramid nylon or optional Cycloaliphatic epoxy.

- Significantly superior bus bracing than standoff type A20 insulators
- Significantly increased creep distance phase-to-phase and phase-to-ground
- Improved endurance from fault incidents
- Minimizes bus system failures due to tracking
- Eliminates additional ground planes in the switchgear for bus supporting systems



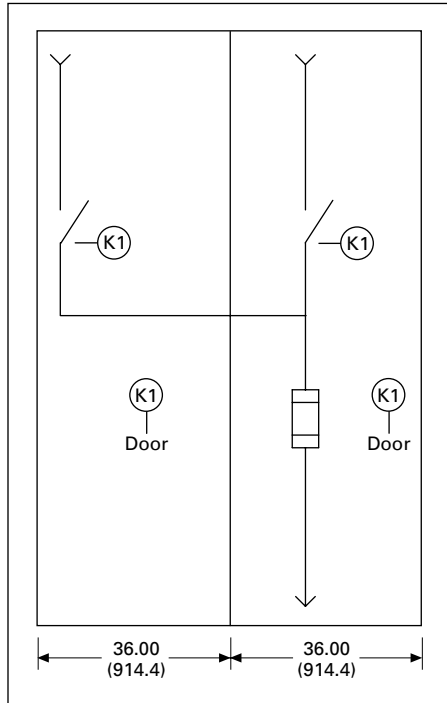
**Bus Support**



**Figure 8.1-1. Switch Operation**

**Duplex Switch Configuration**

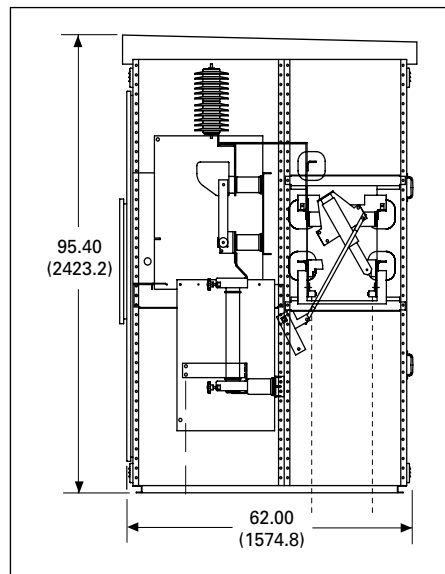
Two MVS load interrupter switch sections can be used to provide cost-effective source selectivity with a common load side bus feeding one load (fused or nonfused). Key interlocks are a standard feature provided to permit only one switch to be closed at one time and prevent opening any switch door unless both switches are open.



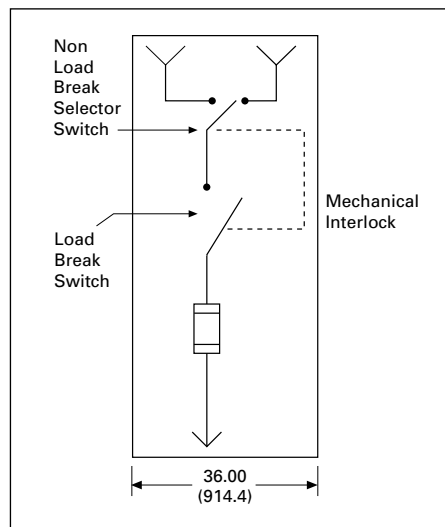
**Figure 8.1-2. Typical Duplex Switch Configuration with One K1 Key—Dimensions in Inches (mm)**

**Two-Position, No-Load Selector Switch**

Eaton’s MVS load interrupter switches can be used to provide the most cost-effective source selectivity solution in a single compact structure with a two-position Type MVS non-loadbreak selector switch in series with the load break MVS switch. **This selector switch is mechanically interlocked such that operation can be performed only when the load interrupter switch is in the open position.** Also, neither the MVS switch nor the main door can be closed without the selector switch being positively locked in one of the two feeder positions.



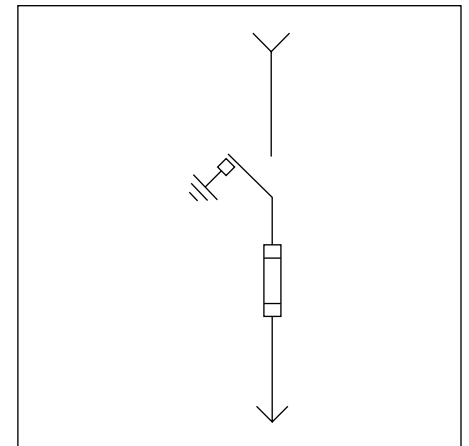
**Figure 8.1-3. Typical Two-Position Selector Switch for Bottom Cable Entrance—Dimensions in Inches (mm)**



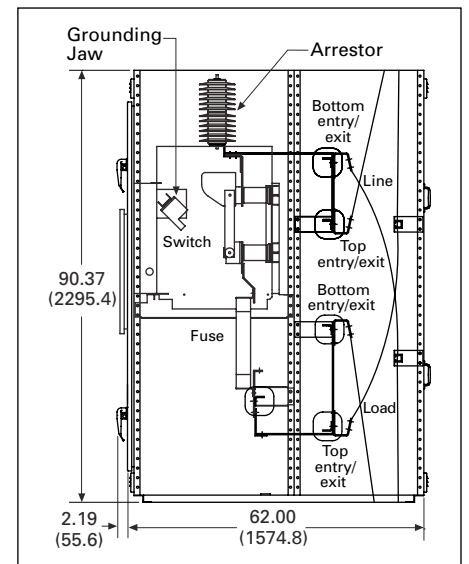
**Figure 8.1-4. Typical Selector Switch Configuration—Dimensions in Inches (mm)**

**Loadbreak Switch with Grounding Jaw**

The loadbreak switch can be supplied with optional grounding jaws for automatic grounding of the load circuit. When the switch is opened, the switch main blades engage grounding jaws to ground the load circuit. **This feature cannot be used in a duplex switch configuration.** The ground jaw option is available at 5–15 kV. It is meant for applying a static ground, and is not rated for carrying fault currents.

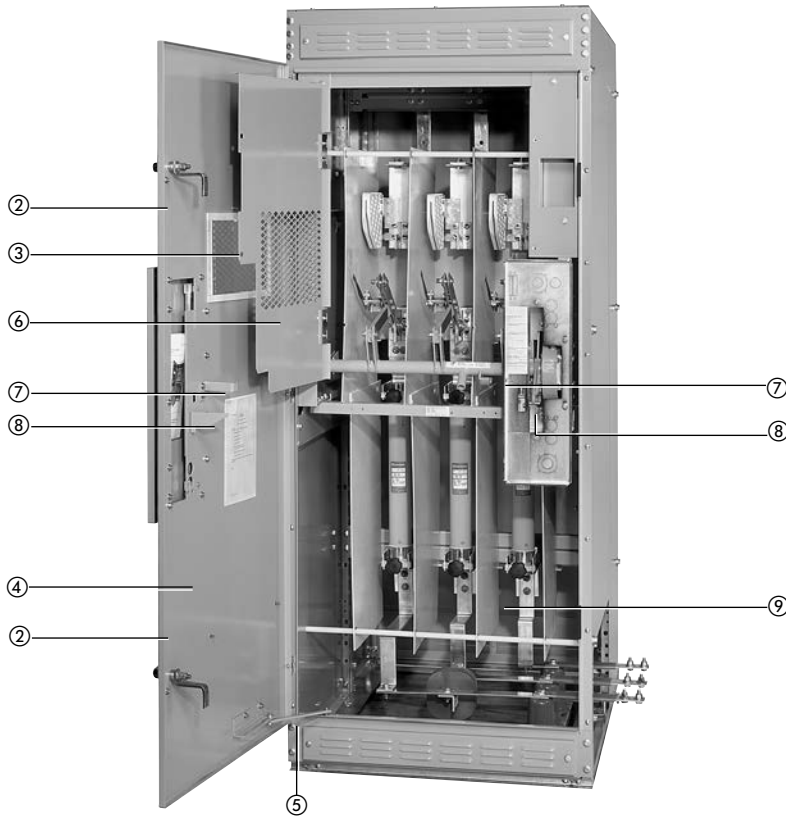


**Figure 8.1-5. Typical Feeder Switch with Optional Grounding Jaw (5–15 kV)**



**Figure 8.1-6. Typical Section View of Feeder Switch with Optional Grounding Jaws**

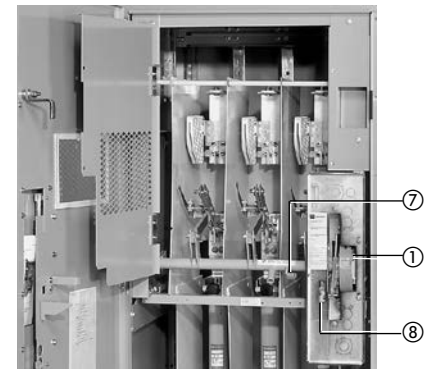
**Construction**



**Typical Switch with Front Door Open**

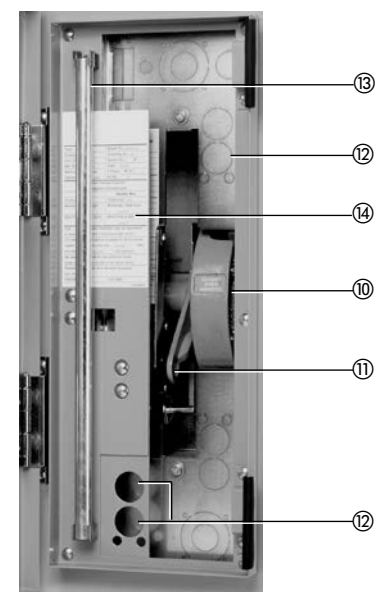
- ① **Switch Mechanism**  
Quick-make, quick-break stored energy operation.  
  
The opening and closing of the switch blades is done by the operating spring. An operator's actions only charge and release the operating spring.  
  
The switch blades cannot be operated in any intermediate position. During the closing operation, full clearance between blades and stationary contacts is maintained until the switch mechanism goes over toggle.  
  
The switch mechanism has only metal-to-metal linkage—no chains or cables are used.  
  
Arc interruption takes place between copper-tungsten tipped auxiliary (flicker) blade and arcing contacts with a DE-ION® arc chute; no arcing takes place between the main blades and the stationary contacts to prolong the life of the main blades.  
  
Blow-out forces cannot be transmitted to the operating handle.

- ② **Provisions for Padlocking Door**  
Handle not visible in the photo.
- ③ **Inspection Window**  
A large 8.00-inch x 16.00-inch (203.2 x 406.4 mm) gasketed, rectangular, high impact viewing window permits full view of the position of all three switch blades through the closed door.
- ④ **Full Height Main Door**  
The door has a return flange and two rotary latch-type handles to provide latching members held in shear. It closes over a projecting frame.
- ⑤ **Foot-Operated Door Stop**
- ⑥ **Grounded Metal Safety Barrier**  
Prevents inadvertent contact with any live part, yet allows full-view inspection of the switch blade position.
- ⑦ **Door Interlock**  
Prevents the door of the enclosure from being opened when the switch is closed.
- ⑧ **Switch Interlock**  
Prevents inadvertent closure of the switch if the door of the enclosure is open.



**Switch with Hinged Screen Barrier Open**

- ⑨ **High Quality Insulation**  
Bus and switch insulators, switch drive rod barriers between phases, and barriers between outer phases and the housing, are of high strength, non-hygroscopic, track-resistant glass polyester as standard. Optional switch, fuse and main bus epoxy insulation system is available.
- ⑩ **Red-Green Switch Position Indicators**
- ⑪ **Provisions for Padlocking Switch Open or Closed**
- ⑫ **Provisions for Door and Switch Key Interlocks**
- ⑬ **The Operating Handle**  
It is conveniently located behind a small access door giving the structure a smooth homogeneous appearance and discourages casual contact by unauthorized personnel.
- ⑭ **Switchgear Assembly Rating Nameplate**



**Switch Operating Compartment Door Open**

## Mini-MVS (26-Inch Wide)



**Mini-MVS Switchgear Assembly**  
*W = 26.00 inches (660.4 mm)*  
*H = 66.00 inches (1676.4 mm)*  
*D = 27.25 inches (692.2 mm)*

Eaton's Mini-MVS switchgear assemblies are rated 200 A, 4.76 kV. The medium-voltage Mini-MVS switchgear assembly is for use in power distribution, transformer primary connections and isolation applications requiring a stand-alone assembly, cable in/cable out terminations and manual operation.

The Mini-MVS switchgear assembly is seismically qualified. The assembly is listed by UL® or CSA. The switch is available fused or non-fused. There is an option for an outdoor enclosure. Several built-in interlocks and safety features are provided (see below).

### Mini-MVS Switchgear Assembly

#### Standard Features

- Seismically qualified
- Manually operated switch
- Door-to-switch safety interlocking
- Auxiliary switch, one Form C contact
- Viewing window for switch position
- Provisions for padlocking the switch in the OPEN position
- Provision for padlocking the two door handles closed
- Spare fuse rack
- Grounded metal screen barrier in front of the switch
- Cycloaliphatic epoxy insulators
- Line, load and ground cable lugs for #6 solid-4/0 stranded cable aluminum or copper
- Key interlock provisions
- Listed—UL/CSA

#### Optional Features

- Enclosed type—indoor or outdoor
  - Outdoor enclosure includes space heater

**Note:** If the application requires a heater for condensation, an outdoor enclosure should be selected

- Fused or unfused switch
  - If fused, Eaton's Type CLE current limiting fuses from 10E amperes to 200E amperes are supplied
- Distribution type surge arresters, 3 kV or 6 kV
- Spare fuses

## MVS and Mini-MVS Switchgear Assembly Ratings

**Table 8.1-1. Switchgear Assembly Main Cross Bus Ratings**

Rated Maximum Voltage	Rated BIL	Rated Main Bus Current	Rated Momentary Short-Circuit Current		Rated Short-Time Short-Circuit Current (2 sec.)
			kA Asym	kA Peak	
kV	kV	Amperes	kA Asym	kA Peak	kA rms Sym.
4.76	60	600–1200	40	65	25
4.76	60	600–1200	61	99	38
4.76	60	600–1200	80	130	50
4.76	60	1200	101	164	63
4.76	60	2000	61	99	38
4.76	60	2000	80	130	50
4.76	60	2000	101	164	63
15	95	600–1200	40	65	25
15	95	600–1200	61	99	38
15	95	600–1200	80	130	50
15	95	1200	101	164	63

**Table 8.1-2. Mini-MVS Ratings, rms Values**

Description	Unfused	Fused
Rated maximum voltage	4.76 kV	4.76 kV
Impulse withstand voltage (BIL)	60 kV	60 kV
Low frequency withstand voltage	19 kV	19 kV
Frequency	60 Hz	60 Hz
Continuous current, maximum	200 A	200 A
Load current interrupting rating ①	200 A	200 A
Magnetizing interrupting current	4 A	4 A
Short-time short-circuit current, 2 seconds, rms sym	12.5 kA	②
Momentary current, asymmetrical/peak	20 kA/32.5 kA	101 kA/164 kA ③
Fault close current, asymmetrical/peak	20 kA/32.5 kA	101 kA/164 kA ③

① 100% to 80% power factor lagging.

② Not applicable for fused units.

③ Rating with Eaton BHLE fuse.

## Switch Technical Data

Eaton’s MVS switch ratings have been thoroughly tested in recognized high power laboratories with certified inspectors from both UL and CSA organizations. Tests were performed to substantiate all published ratings in accordance with ANSI, IEEE, CSA and NEMA standards.

The testing program included tests of:

- Basic impulse levels
- Momentary withstand
- Short-time withstand
- Fault closing
- Load interrupting at various loads, various power factors
- Mechanical life tests
- Temperature rise test

These tests verified not only the performance of the switch and integrated switch-fuse assembly, but also the suitability of the enclosure venting, rigidity and bus spacing.

The mechanical life test subjected the MVS switch to a number of no load cycles greater than the requirements tabulated in ANSI C37.22 standards. There were no moving or current carrying part failures as a result.

The Fault Close and Load Interrupting test demonstrated significant improved performance above ANSI/IEEE standards. See **Table 8.1-4** and **Table 8.1-5** for results.

**Table 8.1-3. Switch Ratings (Non-Fused)**

Rated Maximum Voltage	Impulse Withstand	Continuous and Load-Break	Fault-Close & Momentary Short-Circuit Current		Rated Short-Time Short-Circuit Current (2 sec.)
			kA Asym	kA Peak	
kV	kV	Amperes	kA Asym	kA Peak	kA rms Sym.
4.76	60	600	40	65	25
4.76	60	600	61	99	38
4.76	60	1200	40	65	25
4.76	60	1200	61	99	38
15	95	600	40	65	25
15	95	600	61	99	38
15	95	1200	40	65	25
15	95	1200	61	99	38

**Table 8.1-4. MVS Switch Duty Cycle for Full Load Operations**

Rated Maximum kV	Switch Load Interrupting Ampere Rating	ANSI Required Number of Load Interrupting Operations	Eaton MVS Switch Number of UL Tested Load Break Operations
4.76	600	50	60
4.76	1200	20	50
15	600	30	60
15	1200	10	50

**Table 8.1-5. MVS Switch Duty Cycle for Fault Close Operations—Non-Fused**

Rated Maximum kV	Switch Fault Close Rating		ANSI Required Number of Fault Close Operations	Eaton MVS Switch Number of UL Tested Fault Close Operations
	kA Asym	kA Peak		
5 and 15	40	65	1	4
5 and 15	61	99	1	1



**Table 8.1-6. Primary Fuses, Standard Ratings and Fused Switch Fault Close Rating**

Type Fuse	Switchgear Rated Maximum Voltage, kV	Fuse Rated Continuous Current Range, Amperes	Rated Interrupting Capacity kA Symmetrical ①	Fused Switch Momentary and Fault-Close Rating ①	
				kA Asym	kA Peak
RBA-200	4.76	10–200	19	30.4	49
RBA-400	4.76	10–200	25	40	65
RBA-400	4.76	0.5–400	37.5	60	97.5
RBA-800	4.76	0.5–400	25	40	65
RBA-800	4.76	0.5–720	37.5	60	97.5
BHLE	4.76	10–450	63	101 ②	164
CLE600/750	4.76	600–750	40	64	104
RBA-200	15	10–200	14.4	23	37
RBA-400	15	0.5–400	25	40	65
RBA-400	15	0.5–400	29.4	47	76
RBA-800	15	0.5–720	25	40	65
RBA-800	15	0.5–720	29.4	47	65
HRBA-400	14.4	0.5–400	34.8	55.7	90
HRBA-800	14.4	0.5–720	34.8	55.7	90
BHLE	15	10–250	63	101 ②	164
BHCL	15	300	63	101 ②	164

① When RBA expulsion fuses are used, and two ratings appear, the lower rating applies when the lower-rated switch (15 kV, 40 kA fault close, 25 kA short-time current) versus the higher rating that applies when the higher-rated switch (15 kV, 61 kA fault close, 38 kA short-time) is used.

② UL and CSA listed integrated rating with an Eaton BHLE or BHCL fuse.

## Motor Operated MVS

### Application

Eaton's MVS Pow-R-Drive™ motor operator makes possible the safety and convenience inherent in remote switch operation.



**Motor Operated MVS Switch**

### Description

A MVS Pow-R-Drive motor operated switch is a standard, manually operated switch in combination with a heavy-duty electric motor-driven linear actuator that charges the spring. The linear actuator is located in a separate isolated low-voltage compartment. During electrical operation, it smoothly and quietly extends or retracts the proper distance to cause the switch mechanism to operate.

Standard motor operators are mounted in the switch enclosure. This eliminates the need for a separate motor compartment conserving floor space.



**Manual Operation Override**

### Manual Operation

To operate manually, loosen the holding screw that keeps the pin connecting the linear actuator to the mechanism, and remove the pin. Remove the clevis pin on the support of the bottom of the linear actuator. Unplug the cord from the disconnecting terminal block as the actuator is removed and set the actuator aside. The switch can now be operated manually with the removable handle.

### Lock Open Key Interlock

A keyed lock is standard to lock the switch in the open position only.

This lock not only locks the switch in the open position, but also breaks the electrical motor contacts integral to the motor control circuit and permits the key to be removed. With the key, the operator can then open the lock on the switch door. This scheme gives positive assurance that the switch is open and cannot be closed with the door open.

**Metering**

**Electronic Metering and  
Communications Apparatus**

MVS switchgear assemblies can be equipped with Eaton’s family of Power Xpert® and IQ digital meters to monitor a power circuit’s electrical quantities within the capabilities of each device.

Eaton’s power management products provide hardware and software solutions that allow customers to interface with their switchgear at varying levels of sophistication.

Power Xpert and IQ Meters monitor common electrical parameters and communicate the data via standard industry protocols and optional web interfaces. Power Xpert Gateways consolidate devices into a single web browser interface and provide Ethernet connectivity. Eaton’s Foreseer web-based software system can display, analyze and store data from multiple devices across the facility to enable management of the customer’s power system.

**Outdoor Enclosures**

Weatherproofing complying with the requirements of IEEE standard C37.20.3 is available for MVS switchgear assemblies. The weatherproofing consists of sloped roof panels that are joined together with caps. Doors and rear covers are fully gasketed. Externally accessible louvered filtered covers, top and bottom, front and rear, are provided for ventilation. At least one 250 watt heater is provided in each vertical section. Power for the heaters may be supplied from an external source, or an optional integral control power transformer may be specified to provide power for the heaters.



*Outdoor Enclosure*

*Electronic Metering*

## System Options



**Coupling Capacitor  
Type PD Sensor**



**RFCT Sensor**



**InsulGard Relay  
(PD Monitoring)**

### Partial Discharge in Switchgear

Partial discharge (PD) is a common name for various forms of electrical discharges such as corona, surface tracking, and discharges internal to the insulation. It partially bridges the insulation between the conductors. These high frequency discharges are essentially small arcs occurring in or on the surface of the insulation system when voltage stress exceeds a critical value. With time, airborne particles, contaminants and humidity lead to conditions that result in partial discharges. Partial discharges start at a low level and increase as the insulation becomes deteriorated. Examples of partial discharge in switchgear are surface tracking across bus insulation, or discharges in the air gap between the bus and a support (such as where a bus passes through an insulating window between the sections of the switchgear). If partial discharge activity is not detected and corrected, it can develop into a full-scale insulation failure followed by an electrical fault. Most switchgear flashover and bus failures are a result of insulation degradation caused by various forms of partial discharges.

### Sensing and Monitoring

Eaton's Type MVS metal-enclosed switchgear (2.4–27 kV) is corona-free by design. By making switchgear assemblies corona-free, Eaton has made its standard switchgear more reliable. However, as indicated above, with time, airborne particles, contaminants and humidity lead to conditions that cause partial discharges to develop in switchgear operating at voltages 4000V and above. Type MVS switchgear can be equipped with factory-installed partial discharge sensors and a partial discharge sensing relay for continuous monitoring under normal operation. Timely detection of insulation degradation through increasing partial discharges can identify potential problems so corrective action can be planned and implemented long before permanent deterioration develops. Partial discharge detection can be the foundation of an effective predictive maintenance program. Trending of partial discharge data over time allows prediction of failures, which can be corrected before catastrophic failure occurs.

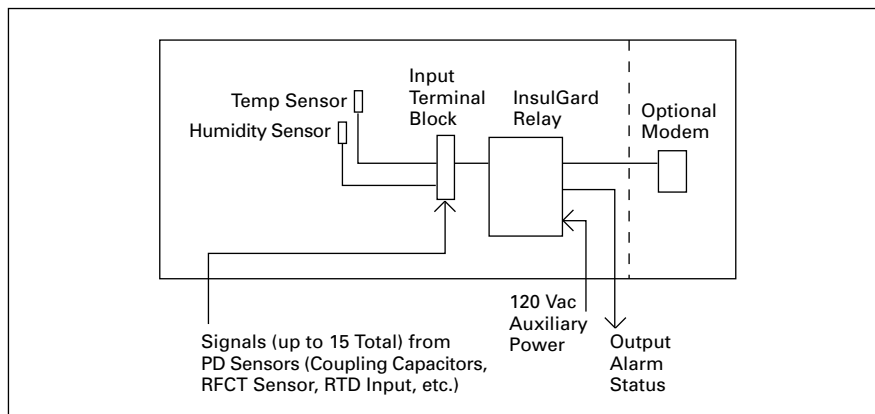
The PD sensing and monitoring system consists of Eaton's InsulGard® relay and PD sensors, specifically developed for application in the switchgear to work with the relay. There are two types of PD sensors used in the switchgear: the first sensor is a coupling capacitor type sensor developed for use with 5 kV, 15 kV and 27 kV switchgear.

The coupling capacitor sensor detects partial discharges within the switchgear cubicle and/or adjacent cubicles, and is typically installed on the load side of the feeder switches or on the main bus. The second sensor is a small donut type radio frequency current transformer (RFCT). It is designed for installation around the ground shields of incoming or outgoing power cables. It detects partial discharges in power cables and monitors for external electrical noise.

Typically one set of coupling capacitor sensors is used at every two cubicles. One RFCT sensor is used for each incoming and outgoing power cable circuit.

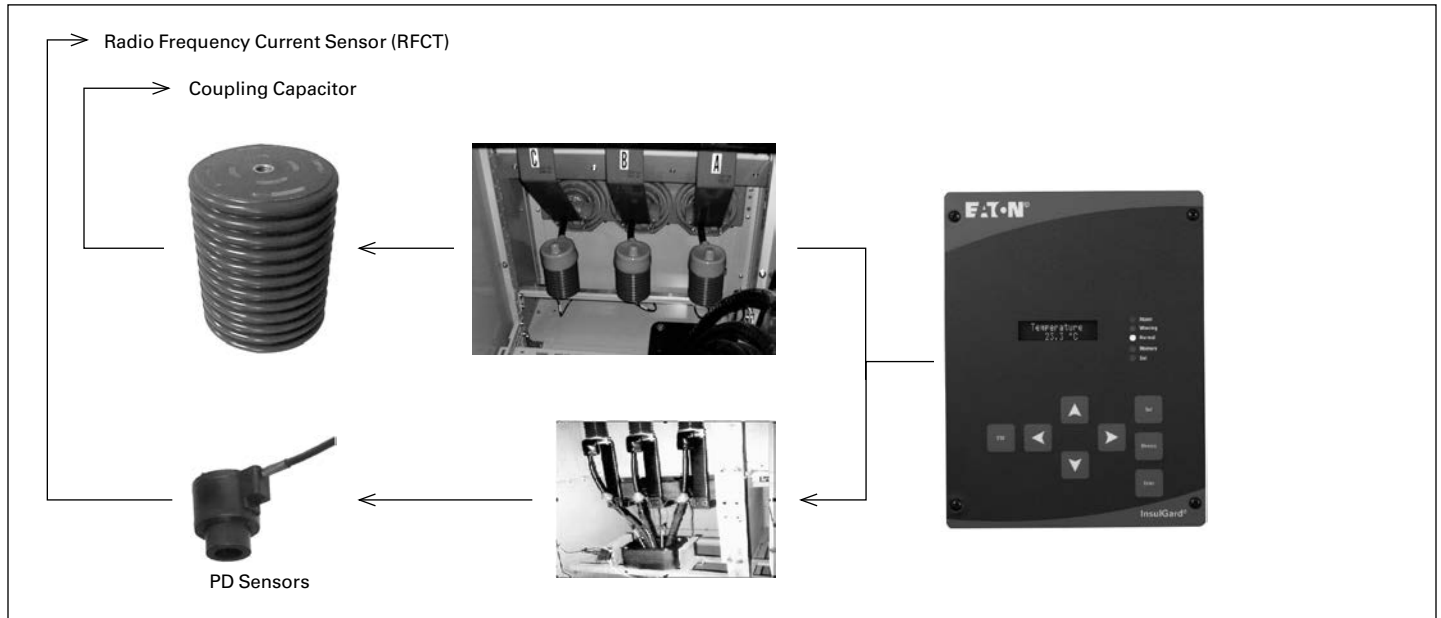
Output signals from sensors (coupling capacitor and RFCT) are wired out to terminal blocks for future or field use, or connected to the InsulGard relay. One InsulGard relay can monitor up to 15 input signals, as well as temperature and humidity. The temperature and humidity sensors are included with each InsulGard relay system. The relay continuously monitors the switchgear primary system for partial discharges and provides an alarm signal (contact closure) when high PD level is detected. Also, data analysis and diagnostics by Eaton engineers can also be provided by remote communication with the InsulGard relay.

**The sensors and InsulGard relay are optional in MVS switchgear.**

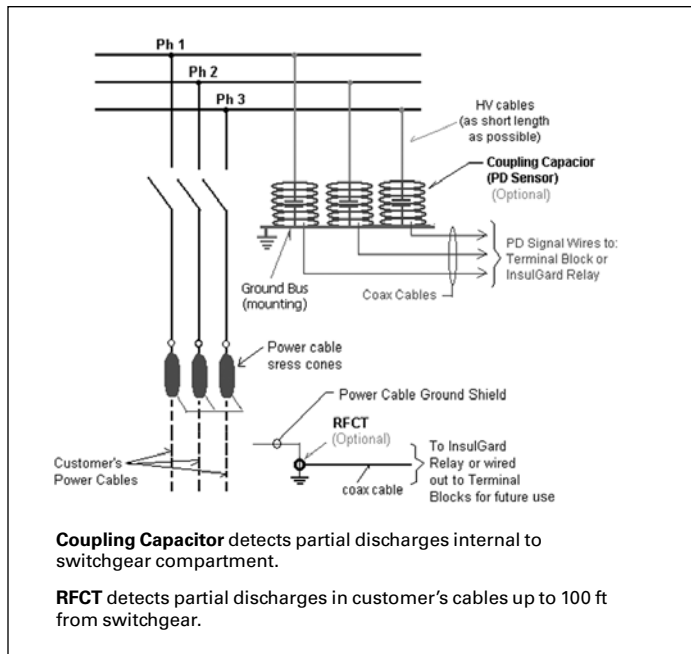


**Figure 8.1-7. InsulGard Relay System**

**Partial Discharge Sensors and Monitoring for Switchgear**



**Figure 8.1-8. How the Process Works—Sensing and Data Collection**



**Figure 8.1-9. Typical Partial Discharge Sensor Connections in MVS Switchgear (5–15 kV)**

**Note:** Use one set of PD sensing capacitors at every two vertical sections, or portion thereof. Use one RFCT at each incoming/outgoing cable circuit.

## MVS Switchgear with Automatic Transfer Control



*Two-Switch Automatic Transfer*



*ATC Controller*

### Application

Eaton's MVS switchgear with an automatic transfer control system is an integrated assembly of motor operated MVS switches, sensing devices and control components. Available in 5–15 kV classes.

It is typically applied where the continuity of service for critical loads from two power sources in either a main/main or a main/tie/main configuration is desired.

MVS switchgear with an automatic transfer control system can meet most automatic throwover requirements as it has a wide variety of operational sequences embodied in one standard automatic transfer control system.

**Please note that the duty cycle of load interrupter switches is limited by ANSI Standard C37.22. Refer to Table 8.1-4 for maximum number of switching operations allowed. If the number of switching operations is expected to exceed the maximum allowed, then load interrupter switches should not be used. Use circuit breakers (refer to Type MSB, MEB, MEF or VCP-W switchgear designs). Also note that the operating times of Eaton's motor operated load interrupter switches are much longer compared to circuit breakers, therefore, the switches are not suitable for closed-transition transfer applications. Use circuit breakers if closed-transition transfer is required.**

### Typical Two-Switch Automatic Transfer Using ATC Controller

Eaton's ATC-900 controller continuously monitors all three phases on both sources for correct voltages. The controller can be applied in a two utility or utility/generator arrangement. Should the voltage of the normal source be lost while the voltage of the alternate source remains normal, the voltage sensing function in the ATC controller will change state starting the time delay function. If the voltage of the normal source is not restored by the end of the time delay interval, the normal switch will open and the alternate source switch will close, restoring power to the load.

### ATC Controller

Eaton's ATC controller is equipped to display history information via the front panel. ATC-900 controller stores 320 time stamped events. Oscillographic data for last 10 events can be downloaded via the USB port or displayed in the controller's display window. The controller allows communications via RS-232 or Modbus through RS-485 port, Ethernet or via USB interface.

### Standard Features

- Voltage sensing on both sources is provided by the ATC controller
- Lights to indicate status of switches, sources, etc.
- Interlocking to prevent paralleling of sources via software
- Control power for the automatic transfer control system is derived from the sensing voltage transformers
- Manual override operation
- Open transition on return to normal
- Programmable time delays on both sources, "OFF DELAY" and "ON DELAY"
- Four programmable digital inputs and outputs
- Single-source responsibility; all basic components are manufactured by Eaton
- Key interlocking of operating system and doors where required to provide operator safety

### Optional Features

- Lockout on phase and/or ground overcurrents and/or internal bus faults
- Blown fuse overcurrent lockout
- Load current, power and PF metering with optional dcT module
- 24Vdc control power input
- Up to four additional I/O modules, each with four programmable digital inputs and digital outputs

**Surge Protection**

IEEE standard C62.11 for Metal Oxide Surge Arresters lists the maximum rated ambient temperature as 40 °C. The ambient temperature inside an Eaton MVS switchgear vertical section may exceed this temperature, especially in outdoor applications where solar radiation may produce a significant contribution to the temperature. Table 8.1-7 lists the recommended minimum duty cycle voltage rating for various system grounding methods. Surge arrester rating is based upon the ambient air temperature in the switchgear vertical section not exceeding 55 °C.

**Table 8.1-7. Suggested Minimum Ratings (kV) for Metal Oxide Surge Arresters Located in Metal-Enclosed Switchgear**

Service Voltage Line-to-Line kV	Distribution Class Arresters						Station Class Arresters					
	Solidly Grounded System		Low Resistance Grounded System		High Resistance or Ungrounded System		Solidly Grounded System		Low Resistance Grounded System		High Resistance or Ungrounded System	
	Arrester Ratings kV						Arrester Ratings kV					
	Nominal	MCOV	Nominal	MCOV	Nominal	MCOV	Nominal	MCOV	Nominal	MCOV	Nominal	MCOV
2.30	3	2.55	3	2.55	3	2.55	3	2.55	3	2.55	3	2.55
2.40	3	2.55	3	2.55	6	5.10	3	2.55	3	2.55	6	5.10
3.30	3	2.55	3	2.55	6	5.10	3	2.55	3	2.55	6	5.10
4.00	3	2.55	6	5.10	6	5.10	3	2.55	6	5.10	6	5.10
4.16	6	5.10	6	5.10	6	5.10	6	5.10	6	5.10	6	5.10
4.76	6	5.10	6	5.10	9	7.65	6	5.10	6	5.10	9	7.65
4.80	6	5.10	6	5.10	9	7.65	6	5.10	6	5.10	9	7.65
6.60	6	5.10	6	5.10	9	7.65	6	5.10	6	5.10	9	7.65
6.90	6	5.10	6	5.10	9	7.65	6	5.10	9	7.65	9	7.65
7.20	6	5.10	6	5.10	10	8.40	6	5.10	9	7.65	10	8.40
8.32	9	7.65	9	7.65	12	10.20	9	7.65	9	7.65	12	10.20
8.40	9	7.65	9	7.65	12	10.20	9	7.65	9	7.65	12	10.20
11.00	9	7.65	9	7.65	15	12.70	9	7.65	10	8.40	15	12.70
11.50	9	7.65	10	8.40	18	15.30	9	7.65	12	10.20	18	15.30
12.00	10	8.40	10	8.40	18	15.30	10	8.40	12	10.20	18	15.30
12.47	10	8.40	12	10.20	18	15.30	10	8.40	12	10.20	18	15.30
13.20	12	10.20	12	10.20	18	15.30	12	10.20	12	10.20	18	15.30
13.80	12	10.20	12	10.20	18	15.30	12	10.20	15	12.70	18	15.30
14.40	12	10.20	12	10.20	21	17.00	12	10.20	15	12.70	21	17.00
18.00	15	12.70	15	12.70	27	22.00	15	12.70	18	15.30	27	22.00
20.78	18	15.30	18	15.30	30	24.40	18	15.30	21	17.00	30	24.40
22.00	18	15.30	18	15.30	30	24.40	18	15.30	21	17.00	30	24.40
22.86	18	15.30	21	17.00	—	—	18	15.30	24	19.50	36	29.00
23.00	18	15.30	21	17.00	—	—	18	15.30	24	19.50	36	29.00

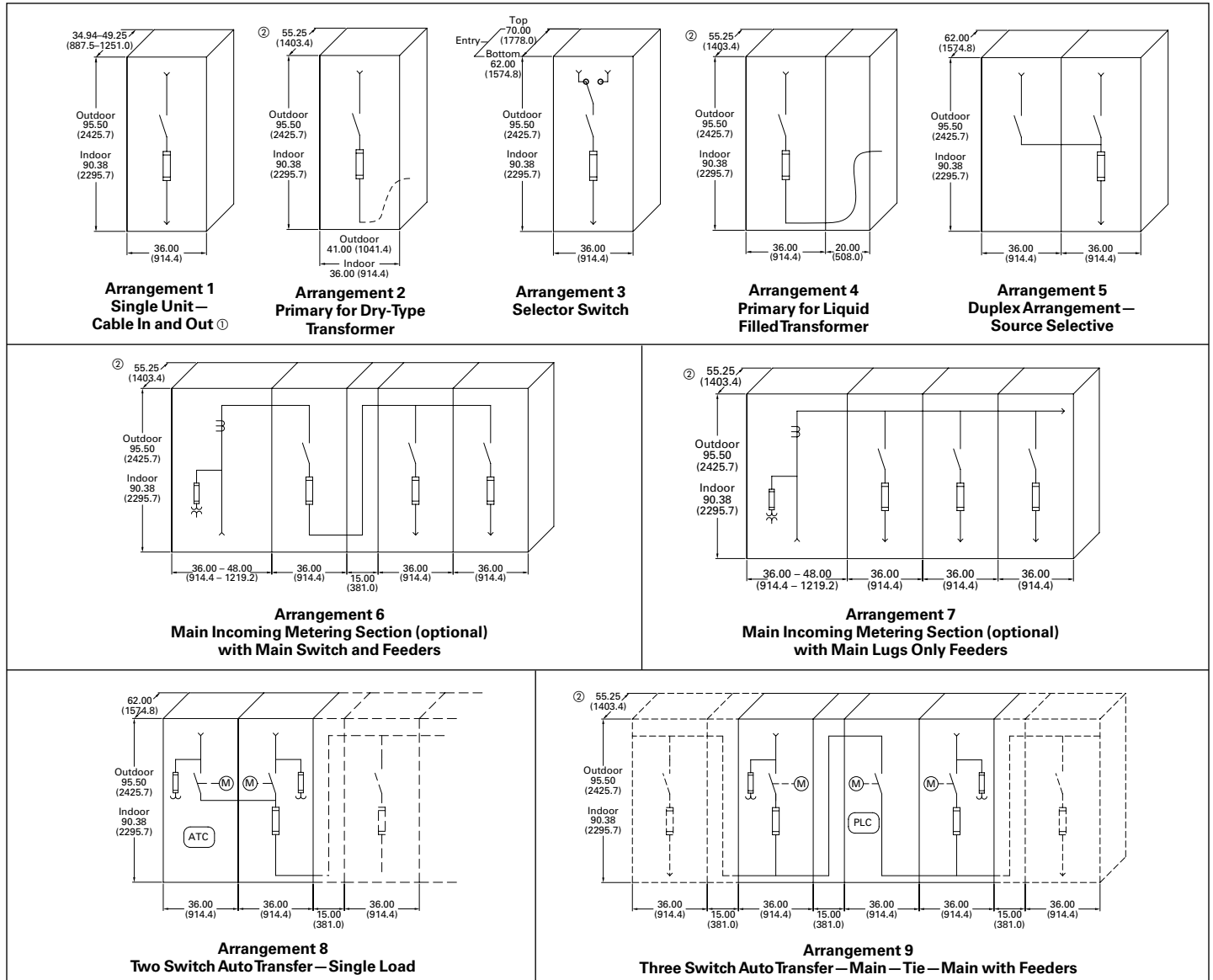
**Note:** MCOV = Maximum Continuous Operating Voltage.

**MVS Layouts**

**Typical Arrangements—5 kV and 15 kV**

The drawings in this section represent the most common arrangements. **Layouts shown are for rear-accessible equipment. Front-accessible designs are available—refer to Eaton.** Many other configurations and combinations are available. Two voltage transformers for customer metering and one control transformer for auxiliary power can be mounted in the structures shown. For control power transformer larger than 1 kVA, additional space is required. **Depth of units will vary** due to cable entrance and exit

requirements, the addition of lightning arresters, instrument transformers, special cable terminators, etc. **Disconnect fuses may require wider sections.** Cables are shown out top and bottom for layout only. Top or bottom must be selected for incoming and for outgoing cables. Structure depth is based on two 500 kcm XLP or EPR insulated cables per phase using preformed slip-on cable termination devices. **Refer to note** below for minimum required depth when more than two cables per phase are used.



**Figure 8.1-10. 5 kV and 15 kV Typical Arrangements—Dimensions in Inches (mm)**

- ① Mini-MVS switch unit in 26.00-inch (660.4 mm) wide, 27.25-inch (692.2 mm) deep and 66.00-inch (1676.4 mm) tall enclosure can be provided for 5 kV, 200 A.
- ② 62.00 (1578.4) for 15 kV MVS.

**Note:** Width for Utility Metering Structures may vary.

**ATC** = Automatic Transfer Controller (see **Page 8.1-14**)

**M** = Motor Operator

**PLC** = Programmable Logic Controller

Minimum depth of MVS unit: Up to two 500 kcm per phase: 55.00 inches (1397.0 mm) or 62.00 inches (1574.8 mm) deep; three or four 500 kcm per phase: 70.00 inches (1778.0 mm) deep, five or six 500 kcm per phase: 80.00 inches (2032.0 mm) deep.

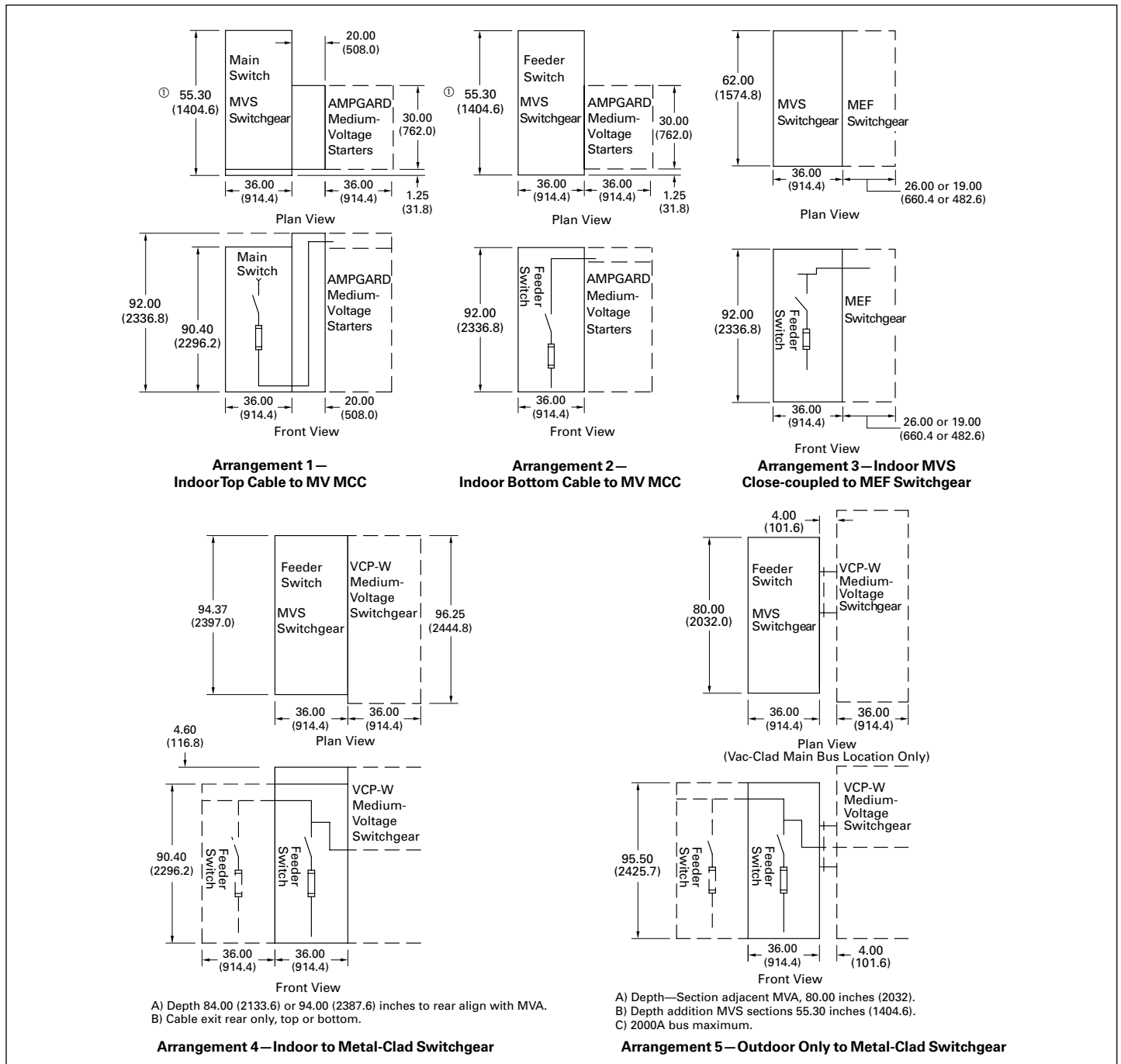
**Not to be used for construction purposes unless approved.**



**Typical Arrangements—MVS Connecting to Other Switchgear**

The drawings in this section represent the most common arrangements. Layouts shown are for rear-accessible equipment. Front-accessible designs are available—see **Page 8.1-21**. Many other configurations and combinations are available. Two voltage transformers for metering and one control transformer for auxiliary power can be mounted in the structures shown. For control power transformer larger than 1 kVA, additional space is required. **Depth of units will vary** due to cable entrance and exit

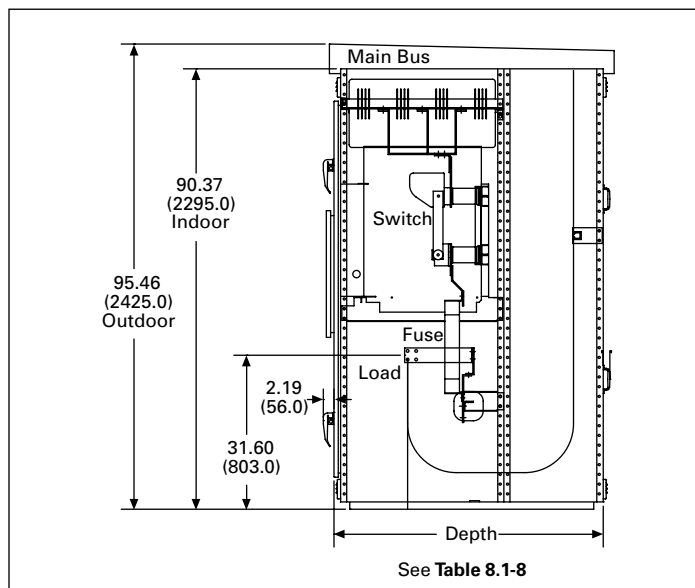
requirements, the addition of lightning arresters, instrument transformers, special cable terminators, etc. **Disconnect fuses may require wider sections.** Cables are shown out top and bottom for layout only. Top or bottom must be selected for incoming and for outgoing cables. Cable sizing is based on two 500 kcmil XLP or EPR insulated cables per phase using preformed slip-on cable termination devices.



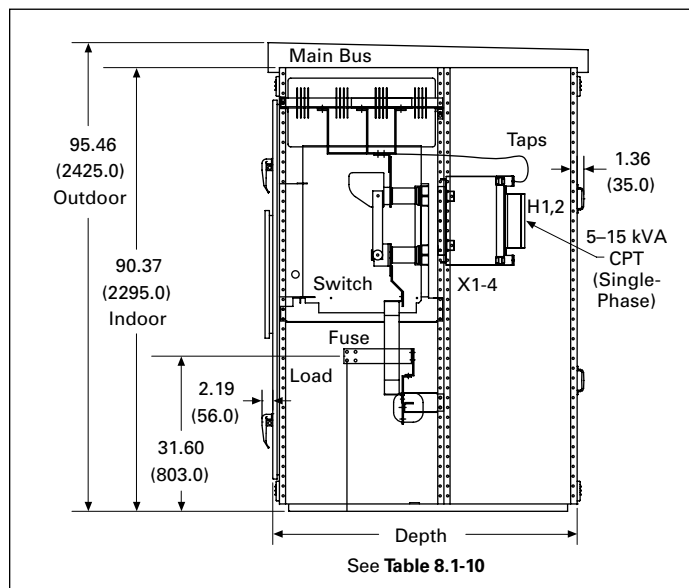
**Figure 8.1-11. Connections to AMPGARD® MCC (7.2 kV Maximum) and to VCPW Switchgear (15 kV Maximum)—Dimensions in Inches (mm)**

① 62.00 (1578.4) for 15 kV MVS.

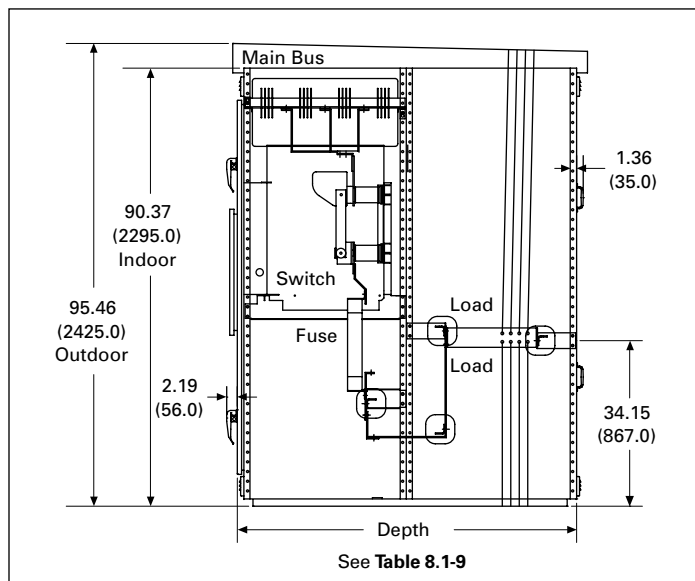
*Not to be used for construction purposes unless approved.*



**Figure 8.1-12. Front Access Feeder Circuit—Fused or Unfused—Dimensions in Inches (mm)**



**Figure 8.1-14. Rear Access Feeder Circuit With Bus Connected CPT—Dimensions in Inches (mm)**



**Figure 8.1-13. Rear Access Feeder Circuit—Fused or Unfused—Dimensions in Inches (mm)**

**Table 8.1-8. Front Access**

No. of Cables per Phase (Based on 500 kcmil)	Minimum Structure Depth—Inches (mm)	
	5 kV	15 kV
1 or 2 out bottom	34.94 (887.5)	34.94 (887.5)
1 or 2 out top	49.25 (1250.0)	49.25 (1250.0)

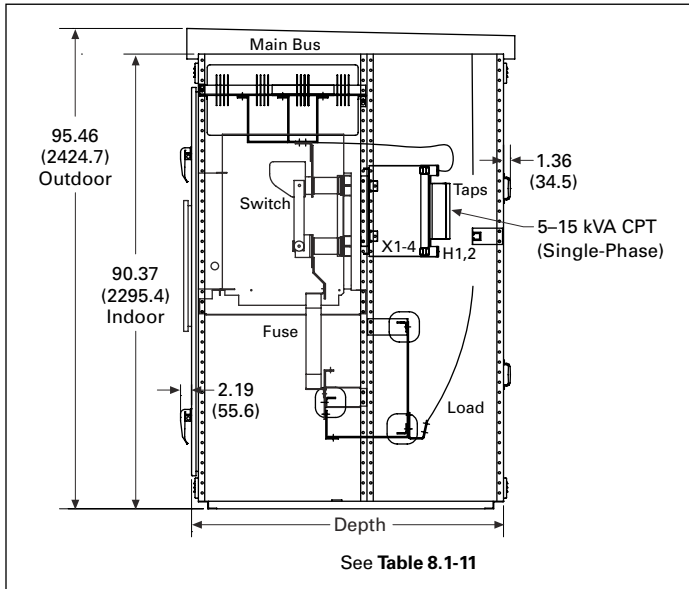
**Table 8.1-9. Rear Access**

No. of Cables per Phase (Based on 500 kcmil)	Minimum Structure Depth—Inches (mm)	
	5 kV	15 kV
3 or 4 top or bottom	62.00 (1574.8)	70.00 (1778.0)
5 or 6 top or bottom	70.00 (1778.0)	80.00 (2032.0)

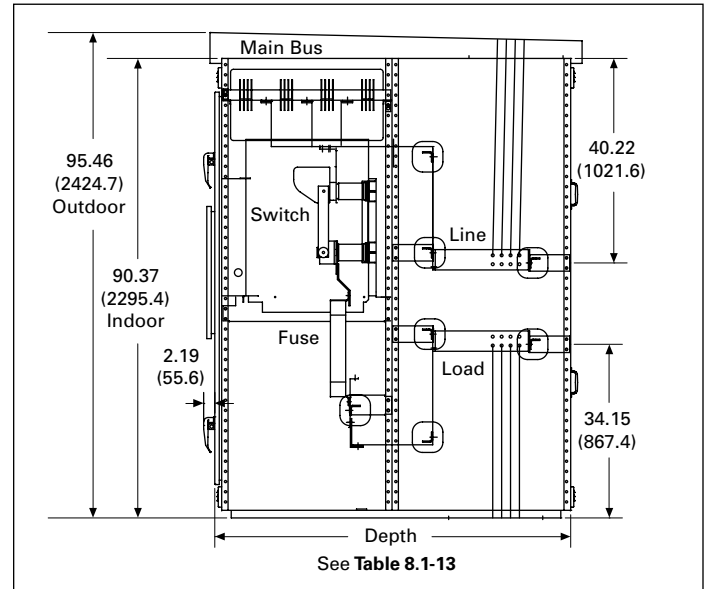
**Table 8.1-10. Rear Access**

No. of Cables per Phase (Based on 500 kcmil)	Minimum Structure Depth—Inches (mm)	
	5 kV	15 kV
1 or 2 top or bottom	62.00 (1574.8)	62.00 (1574.8)

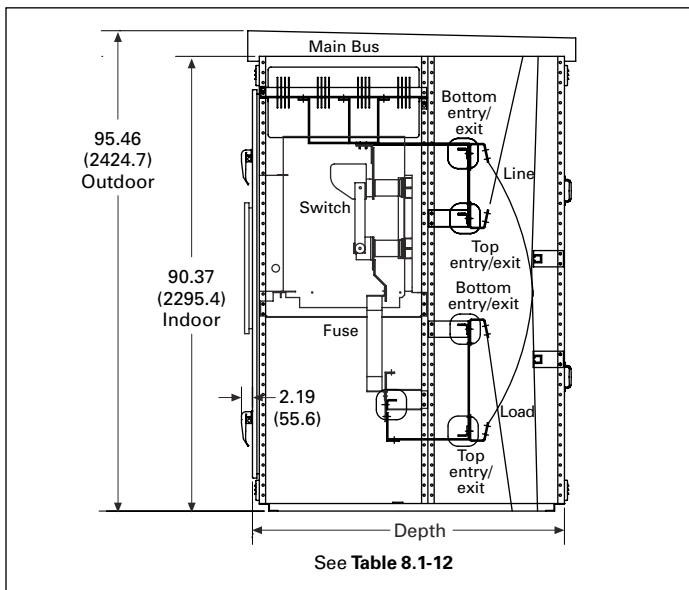
*Not to be used for construction purposes unless approved.*



**Figure 8.1-15. Rear Access Feeder Circuit With Bus Connected CPT—Dimensions in Inches (mm)**



**Figure 8.1-17. Rear Access Cable In/Cable Out With Main Bus—Dimensions in Inches (mm)**



**Figure 8.1-16. Rear Access Cable In/Cable Out With Main Bus—Dimensions in Inches (mm)**

**Table 8.1-11. Rear Access**

No. of Cables per Phase (Based on 500 kcmil)	Minimum Structure Depth—Inches (mm)	
	5 kV	15 kV
1 or 2 out top	70.00 (1778.0)	70.00 (1778.0)

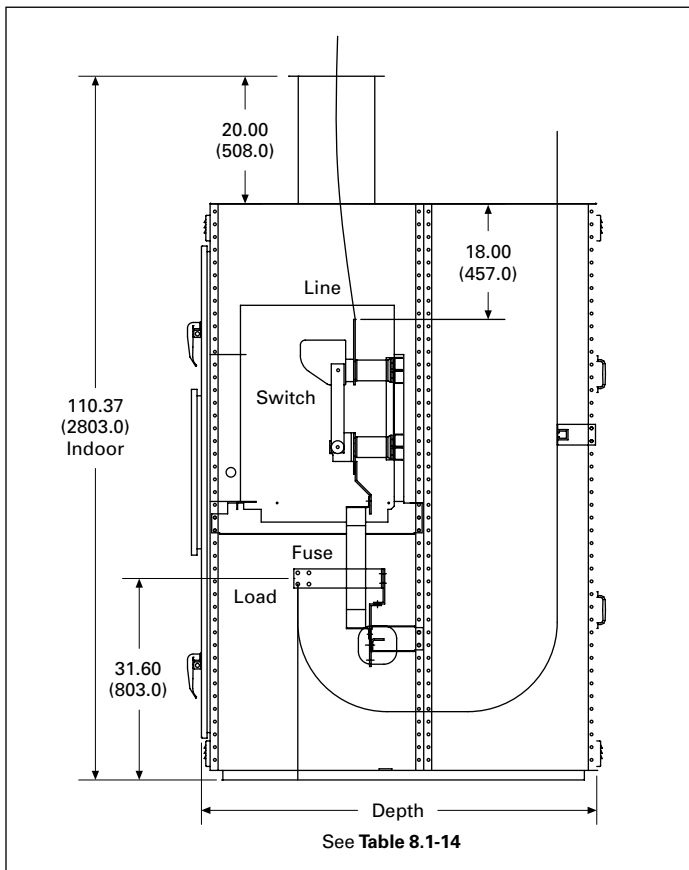
**Table 8.1-12. Rear Access**

No. of Cables per Phase (Based on 500 kcmil)	Minimum Structure Depth—Inches (mm)	
	5 kV	15 kV
1 or 2 top or bottom	55.25 (1403.3)	62.00 (1574.8)

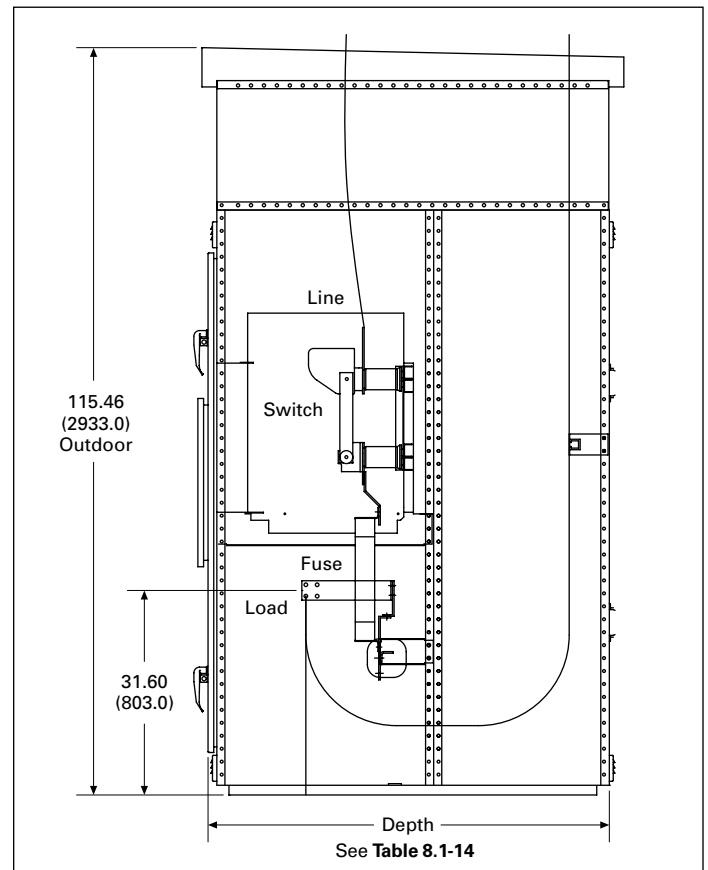
**Table 8.1-13. Rear Access**

No. of Cables per Phase (Based on 500 kcmil)	Minimum Structure Depth—Inches (mm)	
	5 kV	15 kV
3 or 4 top in/bottom out	62.00 (1574.8)	70.00 (1778.0)
5 or 6 top in/bottom out	70.00 (1778.0)	80.00 (2032.0)

**Not to be used for construction purposes unless approved.**



**Figure 8.1-18. Front Access Indoor, Cable In/Cable Out—  
Dimensions in Inches (mm)**

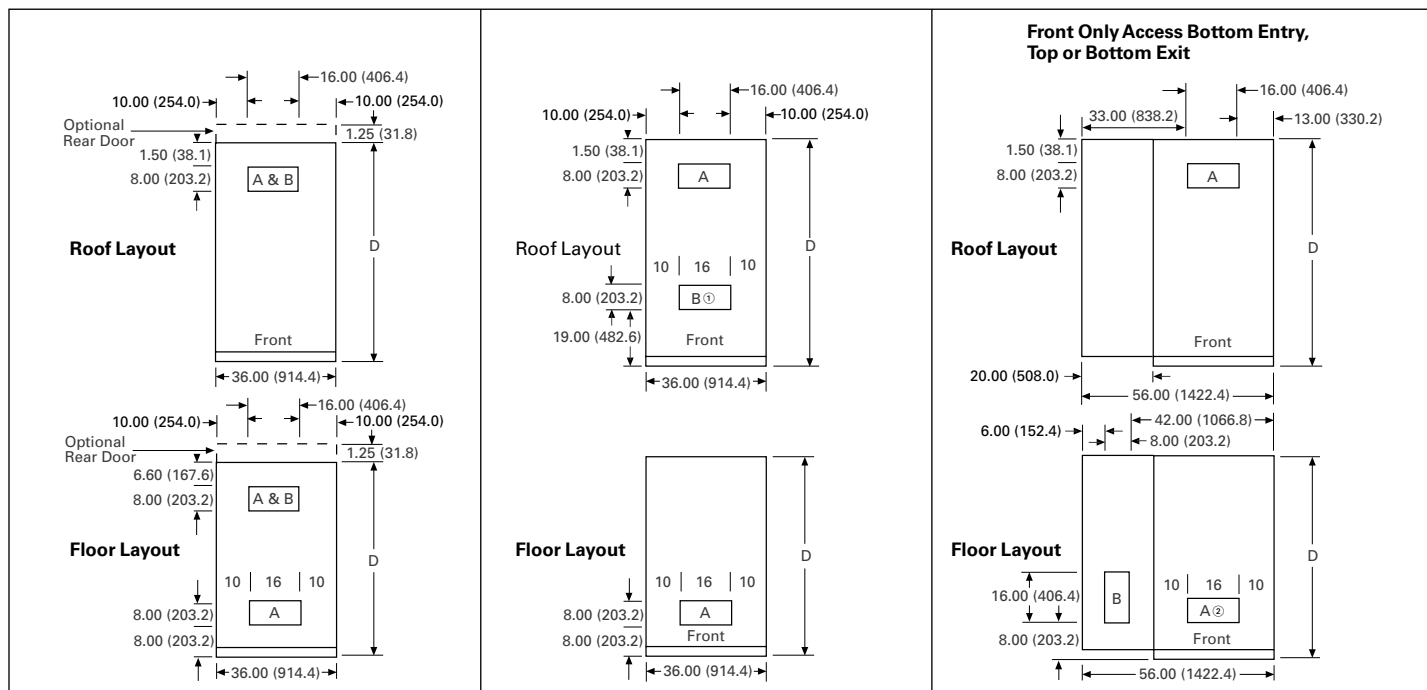


**Figure 8.1-19. Front Access Outdoor, Cable In/Cable Out—  
Dimensions in Inches (mm)**

**Table 8.1-14. Front Access, Cable Exit—Top or Bottom**

No. of Cables per Phase (Based on 500 kcmil)	Minimum Structure Depth—Inches (mm)	
	5 kV	15 kV
1 or 2 top in bottom out	34.94 (887.5)	34.94 (887.5)
1 or 2 top in top out	49.25 (1250.0)	49.25 (1250.0)

***Not to be used for construction purposes unless approved.***



**Figure 8.1-20. 5 kV and 15 kV Roof Layouts and Floor Layouts—Dimensions in Inches (mm)**

① Cable location not available with top main bus.

② When high continuous current fusing or instrumentation is required, consult the Eaton factory for guidance.

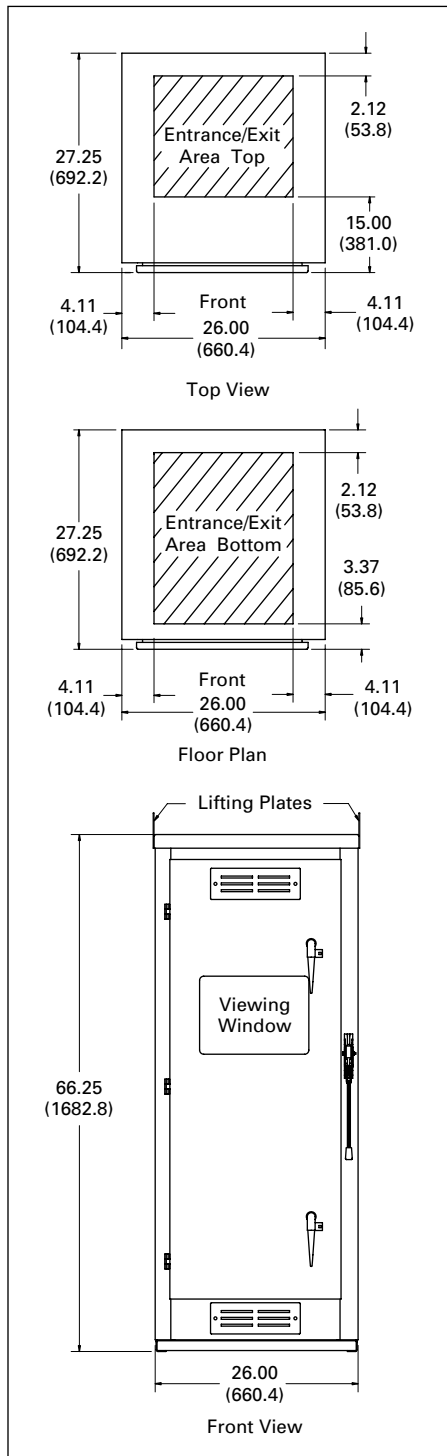
**Note:** A = Power Cable to Load. B = Power Cable from Source. See **Figure 8.1-10** and **Figure 8.1-12** through **Figure 8.1-19** as applicable for dimension D on **Page 8.1-16** and **Page 8.1-18** through **Page 8.1-20**.

**Mini-MVS Layouts**

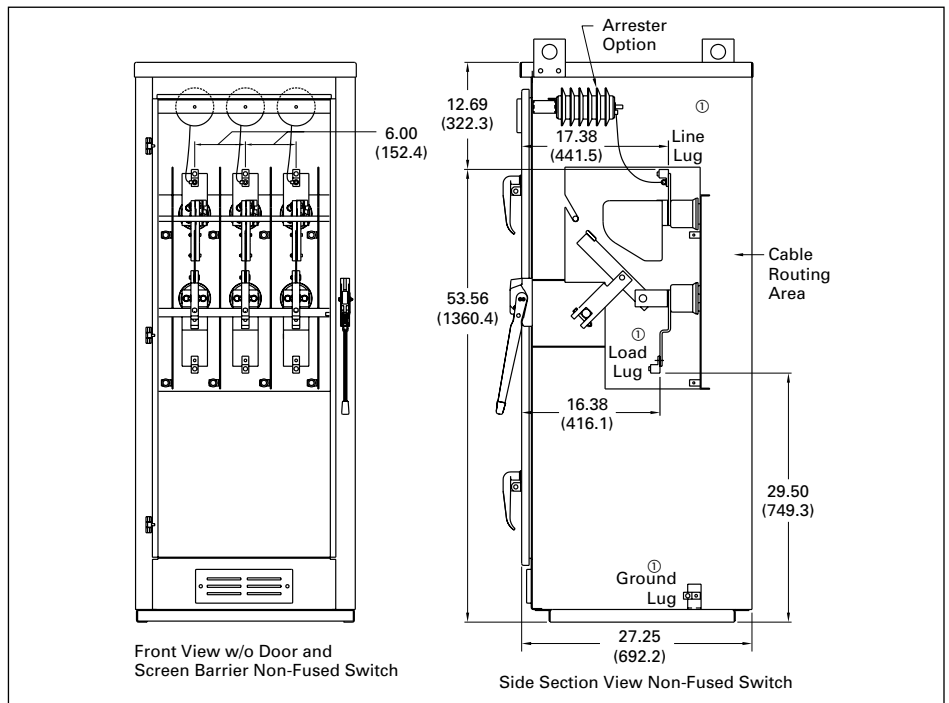
**Mini-MVS Switch (5 kV, 200 A Only)**

**Dimensions and Weights**

Maximum weight of switch assembly is 550 lb (250 kg).

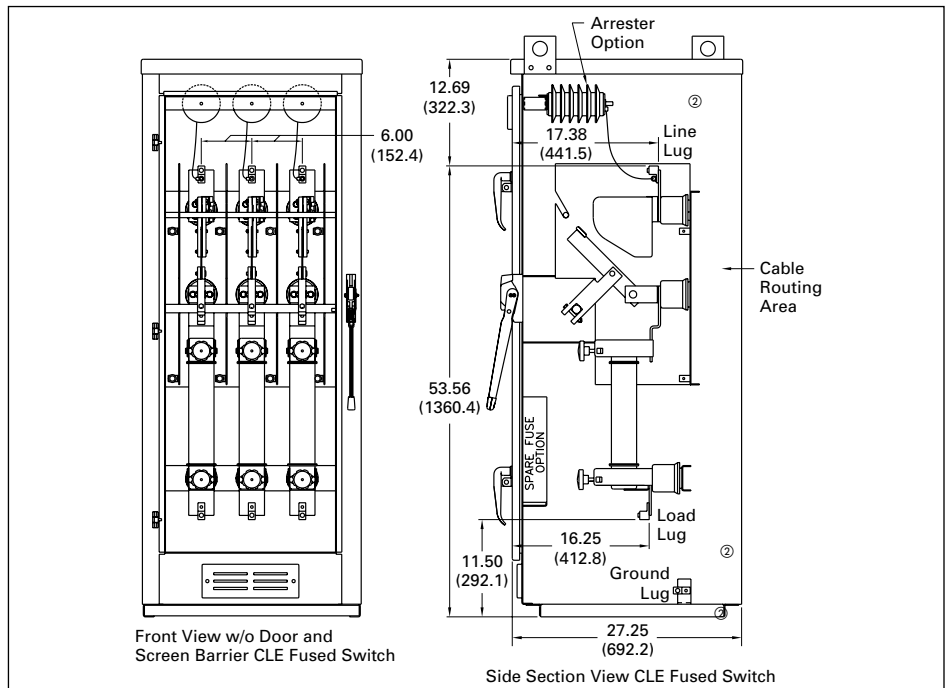


**Figure 8.1-21. Front View and Conduit Entrance—Dimensions in Inches (mm)**



**Figure 8.1-22. Front and Side View of Non-Fused Mini-MVS Switchgear Assembly—Dimensions in Inches (mm)**

① Cable Size #6–2/0, 1/Phase.

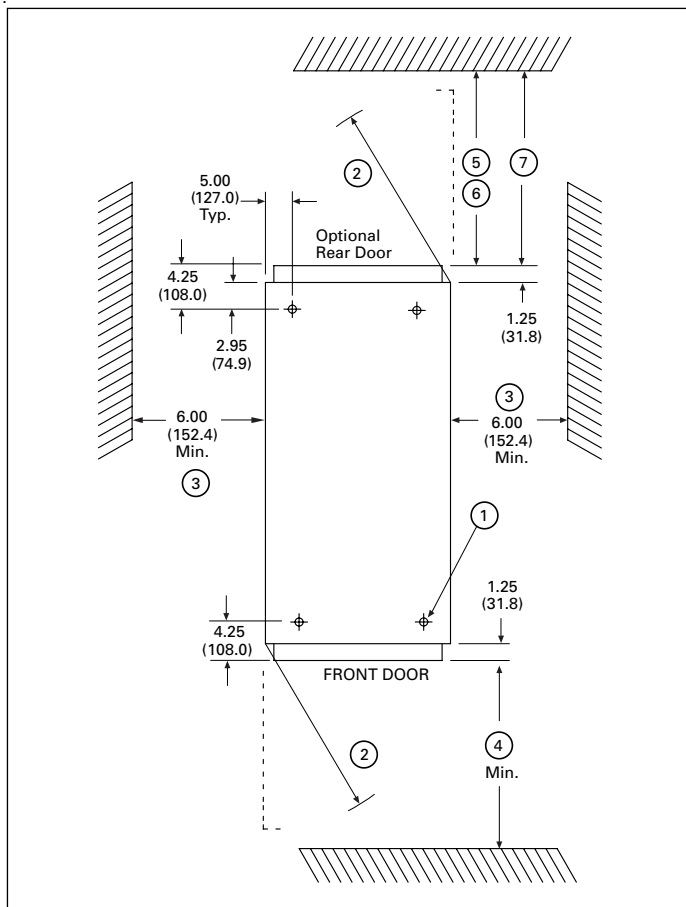


**Figure 8.1-23. Front and Side View of Fused CLE Mini-MVS Switch Assembly—Dimensions in Inches (mm)**

② Cable Size #6–2/0, 1/Phase.

**Note:** The Mini-MVS unit is designed for front access only or as front and rear access. Cable terminations are accessible from the front. Line and load cables can both enter from top, or both can enter from bottom, or line can enter from top and load can exit from bottom. However, for California applications, line cables must enter from top, and load cables must exit from bottom. The unit can be placed against the wall, with a minimum 6.00-inch (152.4 mm) clearance. For rear access applications, a minimum 30.00-inch (762.0 mm) clearance is recommended. Check for additional NEC code clearance requirements.

**Weights**



**Figure 8.1-24. Typical Anchor Plan—5–15 kV Indoor or Outdoor**

- ① Locations for tie-down 0.65 (16.5) diameter holes in four places. Customer provided bolts for anchoring should be 0.50–13 min. SAE Grade 5 (M12 x 1.75 CL 10.9) and tightened to 75 ft-lb (101.7 Nm).
- ② Door swing equals unit width at 90°.
- ③ The standard minimum clearances on side. The authority having jurisdiction may require a larger distance.
- ④ Minimum clearances in front is the width of the widest vertical section plus 1.00 inch (25.4 mm). The authority having jurisdiction may require a larger distance.
- ⑤ The standard minimum recommended distance is 30.00 inches (762.0 mm) for assemblies requiring rear access for installation and maintenance. The authority having jurisdiction may require a larger distance.
- ⑥ For MVS only. If the application is specifically provided by contract as not requiring rear access as stated in 5, then the minimum recommended distance is 6.00 inches (152.4 mm).
- ⑦ If optional rear door is supplied, the minimum is the width of the widest vertical section plus 1.00 inch (25.4 mm). The authority having jurisdiction may require a larger distance.
- ⑧ Finished foundation's surface shall be level within 0.06 inch (1.5 mm) in 36.00 inches (914.4 mm) left-to-right, front-to-back and diagonally, as measured by a laser level.

**Table 8.1-15. Approximate Weights in Lb (kg)**

Switch Description	Indoor	Outdoor
<b>5 kV or 15 kV Class</b>		
Non-fused switch	1500 (681)	1800 (817)
Fuses (3), add	200 (91)	200 (91)
Indoor transition	300 (136)	—
Outdoor throat	—	500 (227)

*Not to be used for construction purposes unless approved.*

**Eaton**  
1000 Eaton Boulevard  
Cleveland, OH 44122  
United States  
Eaton.com

© 2019 Eaton  
All Rights Reserved  
Printed in USA  
Publication No. CA022009EN / Z22791  
May 2019

Eaton is a registered trademark.

All other trademarks are property  
of their respective owners.